



Repair Manual Golf 2004 ➤ Golf 2009 ➤

Engine Mechanical, Fuel Injection and Ignition							
Engine ID	BGP	BGQ	CBT A	CBU A	Volkswagen AG. Volkswagen AG does not		

Edition 07.2014





List of Workshop Manual Repair Groups

Repair Group

- 00 - General, Technical Data
- 10 - Engine Assembly
- 13 - Crankshaft, Cylinder Block
- 15 - Cylinder Head, Valvetrain
- 17 - Lubrication
- 19 - Cooling System
- 24 - Multiport Fuel Injection
- 26 - Exhaust System, Emission Controls
- 28 - Ignition/Glow Plug System



Technical information should always be available to the foremen and mechanics, because their careful and constant adherence to the instructions is essential to ensure vehicle road-worthiness and safety. In addition, the normal basic safety precautions for working on motor vehicles must, as a matter of course, be observed.



Contents

00 - General, Technical Data	1
1 General Information	1
1.1 Safety Precautions	1
1.2 Clean Working Conditions	3
1.3 Engine Contaminants	4
1.4 Cylinder Numbering	4
2 Specifications	5
2.1 Engine Number/Engine Characteristics	5
10 - Engine Assembly	7
1 Specifications	7
1.1 Fastener Tightening Specifications	7
2 Diagnosis and Testing	8
2.1 Engine Mount Adjustment, Checking	8
3 Removal and Installation	9
3.1 Engine Cover	9
3.2 Engine, Removing	9
3.3 Engine and Transmission, Separating	14
3.4 Engine, Securing to the Engine and Transmission Holder VAS6095	18
3.5 Engine, Installing	20
4 Special Tools	22
13 - Crankshaft, Cylinder Block	25
1 General Information	25
1.1 New Connecting Rod, Separating	25
2 Description and Operation	26
2.1 Ribbed Belt Overview	26
2.2 Ribbed Belt Drive Overview	28
2.3 Engine Overview, Rear	30
2.4 Engine Overview, Front/Side	32
2.5 Sealing Flange and Drive Plate/Flywheel Overview	33
2.6 Flywheel Overview	34
2.7 Crankshaft Overview	35
2.8 Crankshaft, Locking	36
2.9 Pistons and Connecting Rod Overview	38
3 Specifications	41
3.1 Crankshaft Dimensions	41
4 Diagnosis and Testing	42
4.1 Crankshaft Axial Clearance, Checking	42
4.2 Crankshaft Radial Clearance, Checking	42
4.3 Pistons and Cylinder Bore, Checking	43
5 Removal and Installation	45
5.1 Ribbed Belt	45
5.2 Ribbed Belt Tensioner, A/C Compressor	46
5.3 Ribbed Belt Tensioner, Generator, Power Steering Pump and Coolant Pump	47
5.4 Vibration Damper	47
5.5 Sealing Flange, Belt Pulley Side	49
5.6 Seal, Transmission Side	52
5.7 Drive Plate	53
5.8 Flywheel	54
5.9 Sealing Flange, Transmission Side	54
5.10 Piston	57



6	Special Tools	60
15 -	Cylinder Head, Valvetrain	63
1	Description and Operation	63
1.1	Cylinder Head Overview	63
1.2	Timing Chain Routing Overview	65
1.3	Camshaft Timing Chain Overview	66
1.4	Oil Pump Timing Chain Overview	67
1.5	Valvetrain Overview	68
2	Specifications	71
2.1	Valve Dimensions	71
2.2	Fastener Tightening Specifications	71
3	Diagnosis and Testing	72
3.1	Compression Pressure, Checking	72
3.2	Valve Timing, Checking	73
3.3	Valve Timing, Adjusting	75
3.4	Valve Guide, Checking	78
4	Removal and Installation	79
4.1	Cylinder Head Cover	79
4.2	Cylinder Head	80
4.3	Vacuum Pump	84
4.4	Timing Chain Cover	86
4.5	Timing Chain Cover Seal	88
4.6	Camshaft	89
4.7	Valve Shaft Seals	92
5	Special Tools	97
17 -	Lubrication	100
1	General Information	100
1.1	Engine Oil	100
1.2	Oil Filter Housing, Draining	100
2	Description and Operation	102
2.1	Oil Pan and Oil Pump Overview	102
2.2	Oil Filter Adapter Overview	104
3	Diagnosis and Testing	106
3.1	Oil Pressure and Oil Pressure Switch, Checking	106
4	Removal and Installation	108
4.1	Lower Oil Pan	108
4.2	Upper Oil Pan	109
4.3	Oil Pump	112
4.4	Oil Pump	115
5	Special Tools	119
19 -	Cooling System	121
1	General Information	121
1.1	Coolant, Draining and Filling	121
2	Description and Operation	124
2.1	Coolant Hose Connection Diagram	124
2.2	Coolant Pump and Thermostat Overview	125
2.3	Radiator and Fan Overview	130
3	Diagnosis and Testing	132
3.1	Cooling System, Checking for Leaks	132
4	Removal and Installation	134
4.1	Coolant Thermostat	134



4.2	Coolant Pump	135
4.3	Fan Shroud and Fan	138
4.4	Radiator	139
5	Special Tools	141
24	- Multiport Fuel Injection	144
1	General Information	144
1.1	Fuel System, Filling and Bleeding	144
2	Description and Operation	147
2.1	Fuel Injection System Component Location Overview	147
2.2	Engine Cover with Air Filter Overview	150
2.3	Intake Manifold Overview	152
2.4	Fuel Rail and Injectors Overview	153
2.5	Intake Manifold Overview	154
2.6	Fuel Rail and Injectors Overview	155
3	Specifications	156
3.1	Fastener Tightening Specifications	156
4	Diagnosis and Testing	157
4.1	Fuel Injector, Checking	157
5	Removal and Installation	159
5.1	Engine Cover with Air Filter	159
5.2	Throttle Valve Control Module J338	159
5.3	Intake Manifold	161
5.4	Fuel Injectors	164
5.5	Engine Control Module, without Anti-Theft Protection	166
5.6	Engine Control Module, with Anti-Theft Protection	167
5.7	Engine Control Module, without Anti-Theft Protection	169
5.8	Engine Control Module, with Anti-Theft Protection	170
6	Special Tools	174
26	- Exhaust System, Emission Controls	177
1	Description and Operation	177
1.1	Secondary Air Injection System Overview	177
1.2	Exhaust Manifold Overview	179
1.3	Exhaust Pipe with Catalytic Converter Overview	180
1.4	Exhaust Pipe with Catalytic Converter Overview	182
1.5	Muffler Overview	184
2	Specifications	185
2.1	Fastener Tightening Specifications	185
3	Diagnosis and Testing	186
3.1	Secondary Air Injection Solenoid Valve, Checking	186
4	Removal and Installation	187
4.1	Secondary Air Injection Pump Motor V101	187
4.2	Secondary Air Injection Solenoid Valve N112	188
4.3	Exhaust Pipe with Catalytic Converter	189
4.4	Muffler	190
4.5	Exhaust System, Aligning	191
5	Special Tools	193
28	- Ignition/Glow Plug System	194
1	Description and Operation	194
1.1	Ignition System Component Overview	194
1.2	Knock Sensor Overview	196
2	Specifications	198



2.1	Test Data and Spark Plugs	198
3	Removal and Installation	199
3.1	Ignition Coil with Power Output Stage	199
4	Special Tools	201
5	Revision History	202

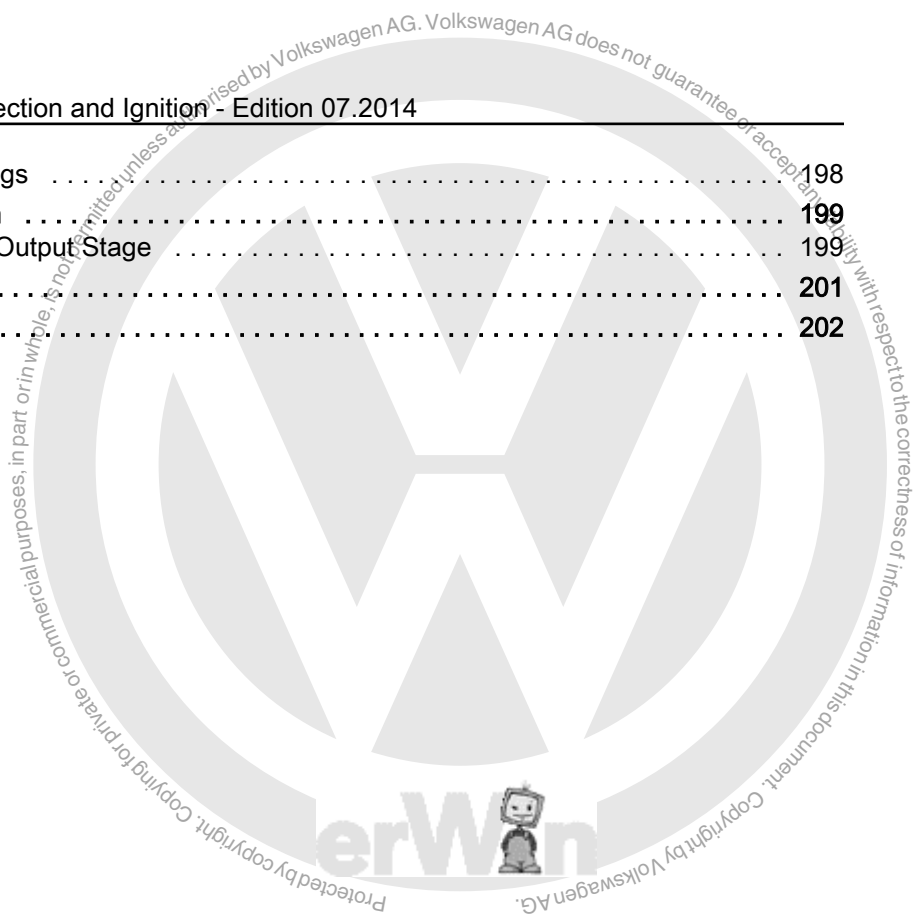



00 – General, Technical Data

1 General Information

(Edition 07.2014)

- ⇒ [“1.1 Safety Precautions”, page 1](#)
- ⇒ [“1.2 Clean Working Conditions”, page 3](#)
- ⇒ [“1.3 Engine Contaminants”, page 4](#)
- ⇒ [“1.4 Cylinder Numbering”, page 4](#)

1.1 Safety Precautions

- ⇒ [“1.1.1 Fuel Supply System”, page 1](#)
- ⇒ [“1.1.2 Road Test with Testing Equipment”, page 2](#)
- ⇒ [“1.1.3 Cooling System”, page 2](#)
- ⇒ [“1.1.4 Ignition System”, page 3](#)

1.1.1 Fuel Supply System



WARNING

Fuel lines are under pressure.

Danger of personal injury to eyes and skin.

Wear protective eyewear and protective clothing in order to avoid injury and contact with the skin. Wrap a cloth around the connection before disconnecting a fuel hose. Open the connection carefully and release the pressure.

For safety reasons, interrupt the current to the fuel pump before opening the fuel system. Otherwise, the fuel pump will activate when the drivers door opens or when the ignition is turned on. It is possible to interrupt the current flow by using one of the following possibilities:

- ◆ *Battery, disconnecting*
- or*
- ◆ *Removing the Fuel Pump - G6- fuse.*
- or*
- ◆ *Disconnecting the connector from the fuel delivery unit flange.*

Always observe the following when removing and installing the fuel level sensor or the fuel pump from a full or partially filled fuel tank.

- ◆ Before starting work, switch the exhaust extraction system on and place an extraction hose close to the fuel tank opening to extract the fuel fumes. If no exhaust extraction system is available, a radial fan (as long as motor is not in air flow) with a displacement greater than 15 m³/h can be used.
- ◆ Prevent fuel from contacting skin! Wear fuel-resistant gloves!



Caution

Note the following whenever working inside the engine compartment due to limited space:

- ◆ *Route all lines and wires in their original locations.*
- ◆ *Ensure sufficient clearance to all moving or hot components.*

1.1.2 Road Test with Testing Equipment

If special testing equipment is required during a road test, note the following:

- ◆ Test equipment must always be secured to the rear seat and operated from there by a second person.

If the vehicle is involved in a collision while testing and measuring equipment is operated from the front passenger seat, the person sitting in that seat could be seriously injured when the airbag deploys.

1.1.3 Cooling System



WARNING

The coolant system is under pressure when the engine is warm.

Risk of scalding due to hot steam and hot coolant.

Reduce pressure by covering the coolant expansion tank cap with a cloth and opening carefully.



Caution

Note the following whenever working inside the engine compartment due to limited space:

- ◆ *Route all lines and wires in their original locations.*
- ◆ *Ensure sufficient clearance to all moving or hot components.*



Note

- ◆ *When the engine is warm the cooling system is under pressure. If necessary release the pressure before beginning any repair work.*
- ◆ *Secure all hose connections with hose clamps, allocation. Refer to the Parts Catalog.*
- ◆ *Use spring type clamp pliers to install spring clamps.*
- ◆ *Always replace gaskets and seals.*
- ◆ *The arrows on coolant pipes and coolant hoses must line up across from each other.*



1.1.4 Ignition System



WARNING

Fuel lines are under pressure.

Danger of personal injury to eyes and skin.

Wear protective eyewear and protective clothing in order to avoid injury and contact with the skin. Wrap a cloth around the connection before disconnecting a fuel hose. Open the connection carefully and release the pressure.

To reduce the risk of personal injury and/or damage to the fuel injection and ignition system, always observe the following:

- ◆ Do not touch or remove ignition wires when the engine is running or turning at starter speed.
- ◆ Only disconnect and reconnect wires for the injection and ignition system, including test leads, if the ignition is turned off.
- ◆ The fuel pump is activated by turning on the ignition and by a drivers door contact switch. If the battery was not disconnected, the connector -arrow- must be disconnected from the fuel delivery unit or the fuse for the Fuel Pump Control Module - J538- must be removed before opening the fuel system.



Caution

Note the following whenever working inside the engine compartment due to limited space:

- ◆ *Route all lines and wires in their original locations.*
- ◆ *Ensure sufficient clearance to all moving or hot components.*

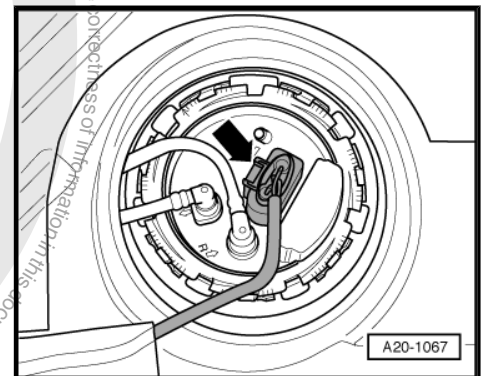

1.2 Clean Working Conditions

When working on the fuel supply/injection system, pay careful attention to the following "5 rules" of cleanliness:

- ◆ Always clean the connection locations and the areas around them before loosening.
- ◆ Place removed parts on a clean surface and cover them using lint free cloths.
- ◆ Carefully cover or seal, unpacked components if repairs cannot be performed immediately.
- ◆ Only install clean components: Remove the replacement parts from their packaging just prior to installing them. Do not use parts that have been stored loose (for example, in a tool box, etc.).
- ◆ When the system is open: Avoid working with compressed air if possible. Do not move the vehicle unless absolutely necessary.



1.3 Engine Contaminants

- ◆ Close off any open intake or exhaust passages with plugs whenever working on the engine to prevent contaminants from getting in. Use plugs from the Engine Bung Set - VAS6122- .

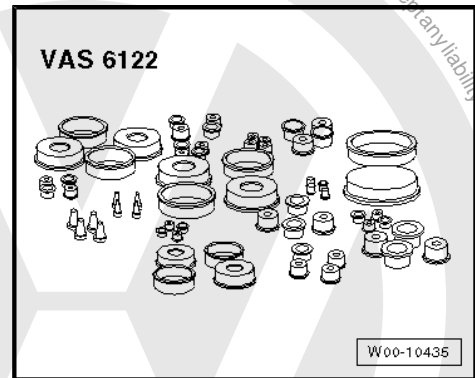

1.4 Cylinder Numbering

- Remove the engine cover with air filter. Refer to [⇒ "5.1 Engine Cover with Air Filter", page 159](#) .



Note

Ignore the -arrow-.



Note

Cylinder 1 is located opposite the force producing side.

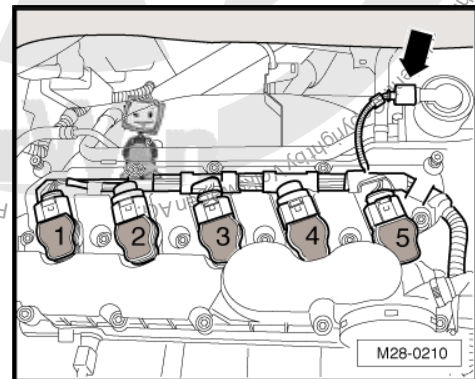

Ignition sequence	1 - 2 - 4 - 5 - 3
-------------------	-------------------



2 Specifications

⇒ **“2.1 Engine Number/Engine Characteristics”, page 5**

2.1 Engine Number/Engine Characteristics

Engine Number

The engine code -arrow A- and engine number -arrow B- (“serial number”) are located on the rear side of the engine, above the partition of the cylinder block/upper oil pan.

The engine code is also stamped on the right cylinder head and on the cylinder block.

A label with the “engine code” and “serial number” is also affixed to the toothed belt guard.

The first three digits describe the mechanical structure of the engine and are still stamped on the engine. The fourth position describes the engine output and torque. It depends on the Engine Control Module (ECM). Four digit engine codes are found on the type plate and vehicle data label. It can also be read via the ECM.

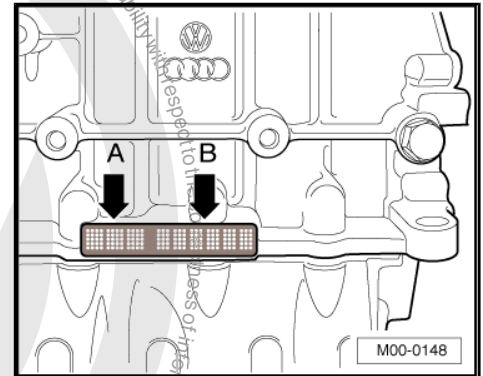

Note

For the vehicle data label location. Refer to Maintenance Procedures Rep. Gr. 03, General Information.

Engine Data

Engine Codes	BGP	BGQ	CBTA	CBUA
Manufactured				
Rabbit, Model Year (MY) 2006 through 2009	from 01/06 through 05/07	from 01/06 through 05/07	from 05/07 through end of production	from 05/07 through end of production
Golf, from MY 2010	---	---	from 05/09	from 05/09
Emission values in accordance with				
Rabbit, from MY 2006 through 2009	ULEV 2 ¹	SULEV ²	ULEV 2 ¹	SULEV ²
Golf, from MY 2010	---	---	Tier2/BIN5 (US coalition)	SULEV ²
Displacement	cm ³	2480	2480	2480
Output	kW at RPM	110 at 5000	110 at 5000	125 at 5700
Torque	Nm at RPM	228 at 3750	228 at 3750	240 at 4250
Bore	diameter mm	82.5	82.5	82.5
Stroke	mm	92.8	92.8	92.8
Compression ratio		9.5	9.5	9.5
Valves per cylinder		4	4	4
RON	minimum	91 unleaded	91 unleaded	95 unleaded ³
Fuel injection, ignition		Motronic ME 7.1.1	Motronic ME 7.1.1	Motronic ME 17.5
Engine idle speed	RPM	680 ⁴	680 ⁴	680 ⁴
Engine speed (RPM) limitation	RPM	approximately 5800	approximately 5800	approximately 6300
Knock control		2 sensors	2 sensors	2 sensors
Variable valve timing		yes	yes	yes
Variable intake manifold		no	no	no
Oxygen Sensor (O2) regulation		2 sensors	3 sensors	3 sensors



Engine Codes	BGP	BGQ	CBTA	CBUA
Catalytic converter	yes	yes	yes	yes
Exhaust Gas Recirculation (EGR)	no	no	no	no
Turbocharger, Supercharger	no	no	no	no
Secondary Air Injection (AIR) System				
Rabbit, from MY 2006 through 2009	yes	yes	yes	yes
Golf, from MY 2010	no	yes	no	yes

- ◆ ¹ ULEV 2 = Ultra Low Emission Vehicles 2
- ◆ ² SULEV = Super Ultra Low Emission Vehicles
- ◆ ³ Also 91 RON but with reduced performance
- ◆ ⁴ Applies to manual and automatic transmissions. If the voltage supply for the Engine Control Module (ECM) drops below 12 volts, the idle speed gradually increases up to 780 RPM.





10 – Engine Assembly

1 Specifications

⇒ “1.1 Fastener Tightening Specifications”, page 7

1.1 Fastener Tightening Specifications

Engine Mount

- 1 - = 40 Nm + an additional 90° (1/4) turn ¹
- 2 - = 20 Nm + an additional 90° (1/4) turn ¹
- 3 - = 60 Nm + an additional 90° (1/4) turn ¹

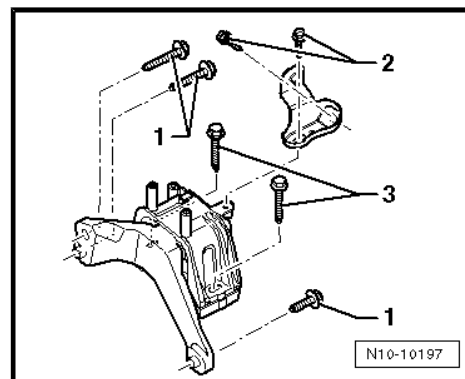

Transmission Mount

- A - = 40 Nm + an additional 90° (1/4) turn ¹
- B - = 60 Nm + an additional 90° (1/4) turn ¹

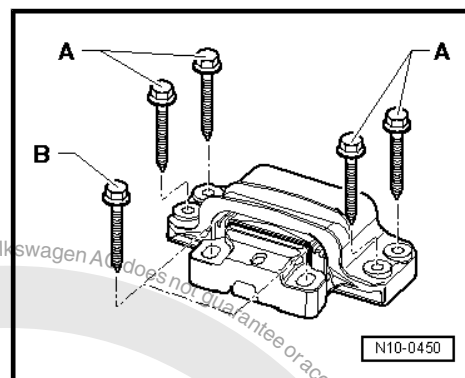

Pendulum Support



Note

First secure the pendulum support to the transmission and then to the subframe.

A - Strength category 8.8: = 40 Nm + an additional 90° (1/4) turn ¹

A - Strength category 10.9: = 50 Nm + an additional 90° (1/4) turn ¹

B - = 100 Nm + an additional 90° (1/4) turn ¹

Removing: First remove the bolt -B-, then the bolts -A-.

Installing: First install the bolts -A-, then the bolt -B-.

◆ ¹ Always replace

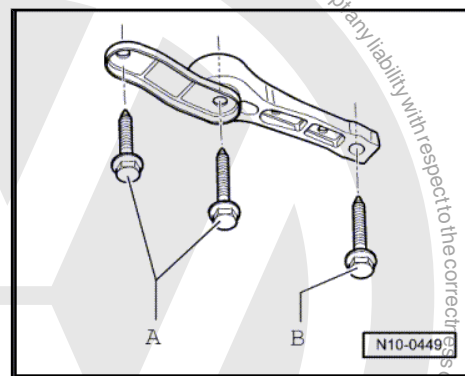



2 Diagnosis and Testing

⇒ "2.1 Engine Mount Adjustment, Checking", page 8

2.1 Engine Mount Adjustment, Checking

- There must be at least 10 to 13 mm -a- between the engine mount bracket -2- and the right longitudinal member.
- The casting edge on the engine mount bracket -2- must be parallel to the engine mount support arm -1-; dimension -x- must be the same at the front and the rear.



Note

Distance -a- can also be checked with corresponding round stock.

Only if there is a noise (the engine or transmission hitting the longitudinal member when driving around curves) and dimension -a- is not within 10 to 13 mm:

- Adjust the engine mount.

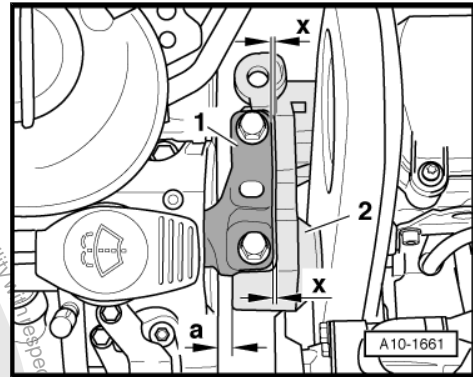



3 Removal and Installation

⇒ [“3.1 Engine Cover”, page 9](#)

⇒ [“3.2 Engine, Removing”, page 9](#)

⇒ [“3.3 Engine and Transmission, Separating”, page 14](#)

⇒ [“3.4 Engine, Securing to the Engine and Transmission Holder VAS6095”, page 18](#)

⇒ [“3.5 Engine, Installing”, page 20](#)

3.1 Engine Cover

- The engine cover is a single component with the air filter housing. Refer to ⇒ [“5.1 Engine Cover with Air Filter”, page 159](#) .

3.2 Engine, Removing



Note

If the engine oil must be drained because of work performed on the removed engine, it should be drained with the engine installed. If the engine hangs on the Engine Lateral Bracket - T03001-, the engine is not in its installed position and less engine oil will drain out.

Special tools and workshop equipment required

- ◆ Hose Clip Pliers - VAS6340-
- ◆ Hose Clip Pliers - VAS6362-
- ◆ Engine-/Gearbox Jack - VAG1383A-
- ◆ Tensioning Strap - T10038-
- ◆ Step Ladder - VAS5085-
- ◆ Engine Holder Bracket - T03000-
- ◆ Cable Ties
- ◆ Foam Mat

For information on securing the engine to the engine stand. Refer to

⇒ [“3.4 Engine, Securing to the Engine and Transmission Holder VAS6095”, page 18](#) .



Note

- ◆ *To perform this procedure, the ground cable must be disconnected from the battery. If a coded radio is installed, obtain the anti-theft code beforehand.*
- ◆ *The engine is removed downward together with the transmission.*
- ◆ *All cable ties which are opened or cut off when removing the engine, must be replaced in the same position when installing the engine.*



Caution

When doing any repair work, especially in the engine compartment, pay attention to the following due to clearance issues:

- ◆ *Route all lines and wires in their original locations.*
- ◆ *To prevent damage to the lines, make sure there is sufficient clearance to all moving or hot components.*

- Remove the engine cover with air filter. Refer to ⇒ ["5.1 Engine Cover with Air Filter", page 159](#) .
- Remove the battery. Refer to ⇒ Electrical Equipment; Rep. Gr. 27 ; Battery; Removal and Installation .
- Remove the cover -1- for the E-box and remove the wire -2-.
- Remove the battery tray bolts -arrows- and remove the battery tray from the vehicle.
- Disconnect the engine wiring harness connector from the Engine Control Module (ECM).

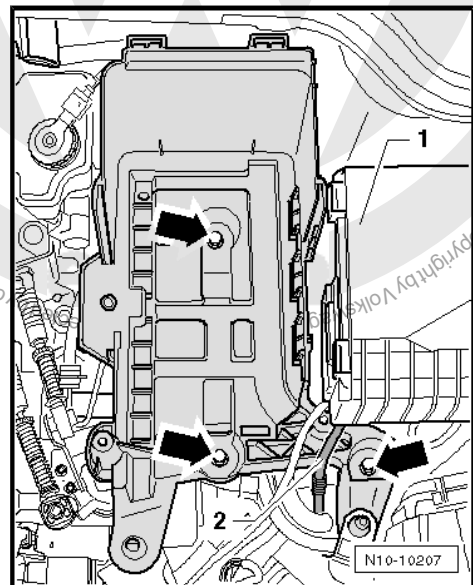

- Release the pass-through for the engine wiring harness in direction of -arrow- and pull off upward.

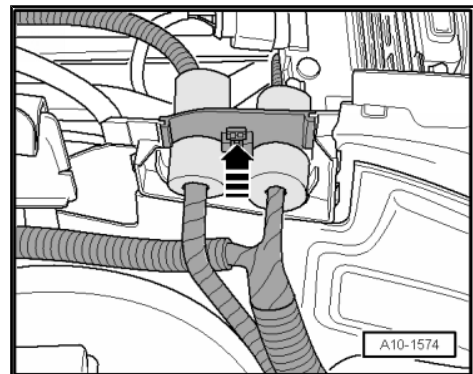



- Open locking mechanisms -arrows- on the wire guide on the longitudinal member.
- Disconnect the connector -4-, open the locking mechanism and lay the engine wiring harness -3- on the engine.

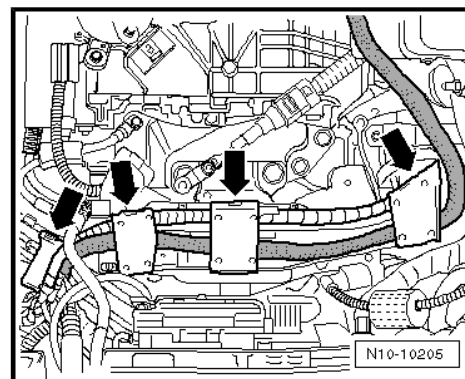

- Disconnect the ground cable -1- and the starter connections -2 and 5-.

With a Automatic Transmission

- Disconnect the connector -6- from the multifunction switch.
- Remove the selector lever cable from the transmission. Refer to => Automatic Transmission; Rep. Gr. 37 ; Removal and Installation .

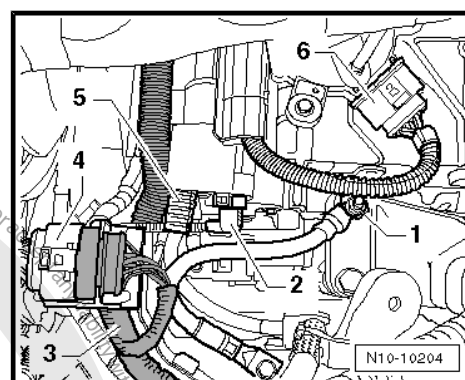

With a Manual Transmission

- Remove the shift mechanism from the transmission. Refer to => Manual Transmission; Rep. Gr. 34 ; Removal and Installation .

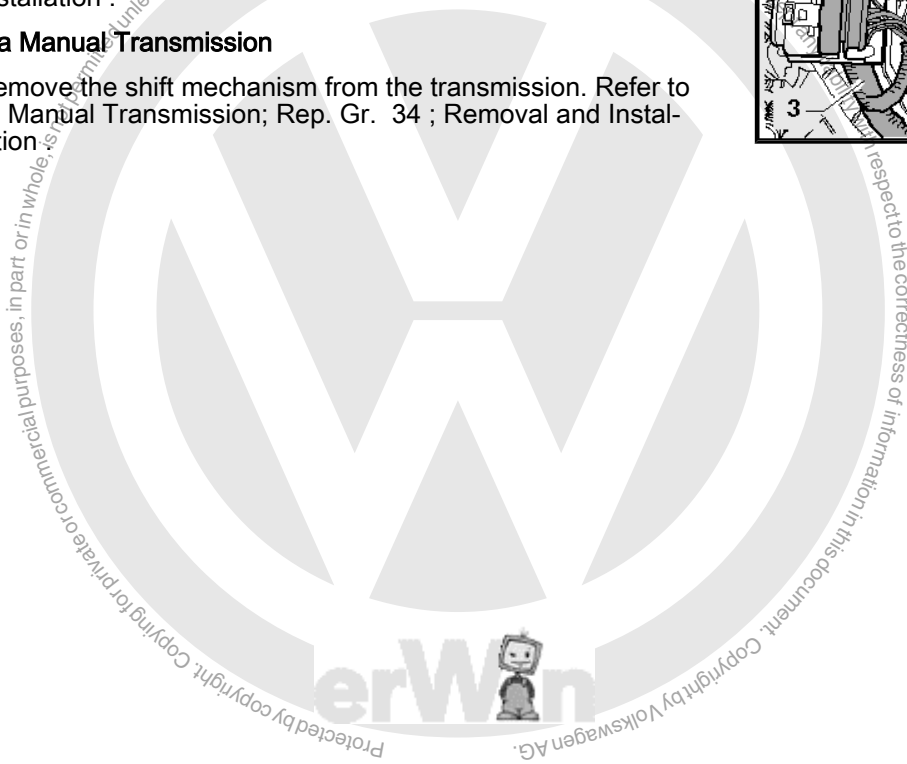



- Remove the brace -1-.
- Remove the slave cylinder bolts -arrows- and cylinder, set it aside, do not open line system.



Caution

Do not press the clutch pedal after removing the slave cylinder. The slave cylinder may be damaged by doing this.

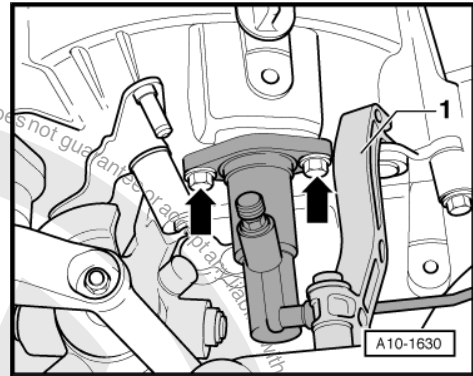

- Disconnect the connector for the backup light switch on the transmission.

Continuation for All

- Disconnect the vacuum hose from the brake booster.
- Disconnect the connector from the Heated Oxygen Sensor - G39- on the bulkhead and free up the electric wiring harness.



WARNING

Hot steam may escape when opening the expansion tank cap. Wear protective goggles and protective clothing to prevent damage to eyes and scalding. Cover the cap with a cloth and open very carefully.

- Drain the coolant. Refer to [⇒ "1.1 Coolant, Draining and Filling", page 121](#) .
- Remove the front section of the right wheel housing liner. Refer to ⇒ Body Exterior; Rep. Gr. 66 ; Removal and Installation .
- Move the lock carrier into the service position. Refer to ⇒ Body Exterior; Rep. Gr. 50 ; Description and Operation .

So that it is possible to remove the engine without opening the refrigerant circuit:

- Remove the ribbed belt. Refer to [⇒ "5.1 Ribbed Belt", page 45](#) .
- Unbolt the Air Conditioning (A/C) compressor from the accessory bracket. Refer to "Refrigerant Circuit Components" in ⇒ Heating, Ventilation and Air Conditioning; Rep. Gr. 87 ; Removal and Installation .



Note

To prevent damage to the A/C condenser and also to the refrigerant lines/hoses, ensure that the lines and hoses are not stretched, kinked or bent.

- Tie up the A/C compressor with the refrigerant hoses still connected.
- Disconnect the connection from the generator and free up the wiring harness.



- Remove the 4 exhaust pipe with catalytic converter to exhaust manifold nuts -2- and the suspended mount bolts -3-.
- Remove the exhaust pipe with catalytic converter -1- from the manifold and tie up firmly to the side. Refer to ⇒ "4.3 Exhaust Pipe with Catalytic Converter", page 189 .

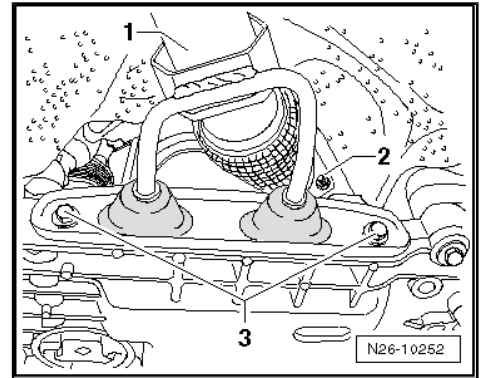

i Note

The coupling element in the exhaust pipe with catalytic converter must not be bent more than 10°, otherwise it may be damaged.

- Remove the right drive axle and remove the left drive axle from the transmission. Refer to ⇒ Suspension, Wheels, Steering; Rep. Gr. 40 ; Removal and Installation .
- Remove the pendulum support.

! WARNING

◆ **The fuel supply line is under pressure. Always wear protective eyewear and protective clothing to prevent injuries and fuel from coming in contact with your skin. Before loosening the fuel lines, place a cloth around the connection point. Remove the hose connection carefully to release the pressure.**

- Disconnect the ventilation line -1-, vacuum line -2- and fuel supply line -3-. Press in the securing ring to disengage the lines.
- Seal the lines so that the fuel system is not contaminated by dirt, etc.

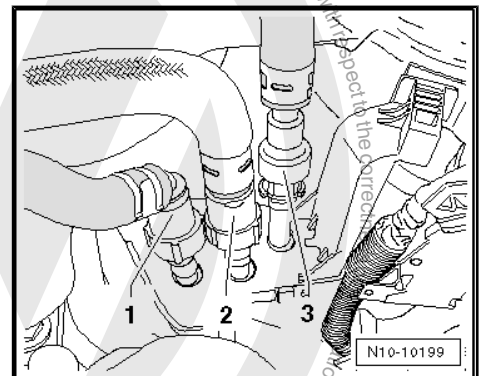

- Remove the bolt -2- and move the windshield washer fluid reservoir -1- toward the front.
- Remove the bolts -6- and disconnect the connector -3-.
- Remove the bolts -5- and place the coolant expansion tank -4- on top of the engine with the hoses connected.

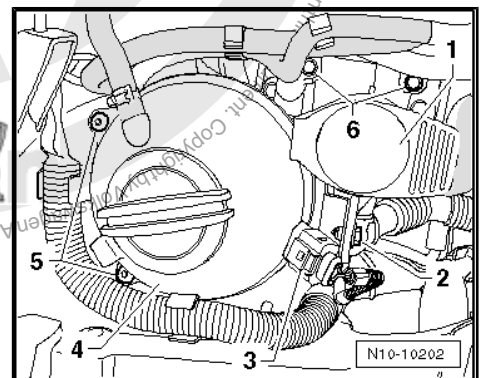

i Note

Slightly loosen the bolts on the engine and transmission mounts before lifting the vehicle.

- Disconnect the coolant lines at the radiator and heater core (quick acting couplings).



- Install the Engine Holder Bracket - T03000- as follows:
 - ◆ Remove the Pin - T03000/3- from the bracket.
 - ◆ Mount the Engine Holder Bracket - T03000- with the Pin - T03000/4- to the cylinder block and tighten the bolts -1 and 2- hand tight.
 - ◆ Then, install the pin - T03000/3- and tighten it to 20 Nm.
 - ◆ Then, tighten the bolts -1 and 2- to 25 Nm.
- Place the engine-/gearboxjack - VAG1383A- under the engine holder bracket - T03000- and lift the engine/transmission assembly slightly.

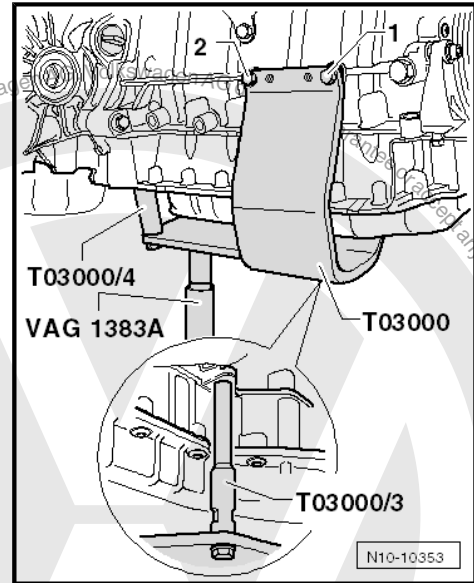

- Remove the engine mount from above. To do this, remove the bolts -1, 2 and 3-.



Note

Remove the rear bolt -2- through a hole in the wheel housing.

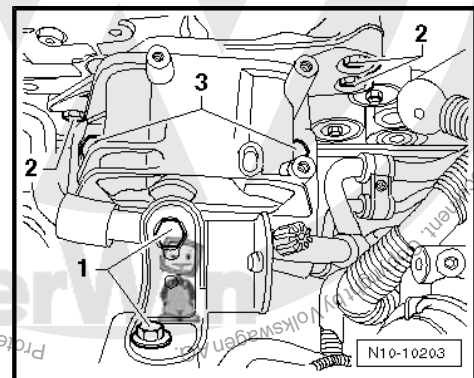

- Remove the transmission mount to transmission mount bracket bolts -arrows- from above.



Note

- ◆ Use the Step Ladder - VAS5085- to remove the mount bolts.
 - ◆ The engine/transmission assembly must be guided with care to prevent damage while lowering it.
- Lower the engine/transmission assembly carefully downward.

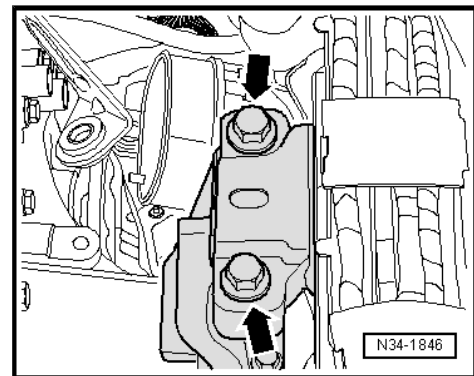

3.3 Engine and Transmission, Separating

⇒ ["3.3.1 With a Automatic Transmission", page 14](#)

⇒ ["3.3.2 With a Manual Transmission", page 17](#)

3.3.1 With a Automatic Transmission

Special tools and workshop equipment required

- ◆ Shop Crane - Load Cap = 700-1200 KG - VAS6100-
- ◆ Shackle - 10-222A/12-
- ◆ Crankshaft Adapter - T03003-
- ◆ Socket SW15 - V/175-
- ◆ Hose Clamps up to 25 mm Dia. - 3094-



- ◆ Hose Clamps up to 40 mm - 3093-

Conditions

- The engine and transmission assembly is removed and secured to the Engine Holder Bracket - T03000- .

 **Caution**

Note the following whenever working inside the engine compartment due to limited space:

- ◆ *Route all lines and wires in their original locations.*
- ◆ *Ensure sufficient clearance to all moving or hot components.*

Separating

- Remove the bracket -1- from the starters upper stud bolt -arrow-.
- Remove the starter upper stud bolt

 **Note**

Mark the coolant hoses on the transmission fluid cooler to prevent mixing them up when installing them again later.

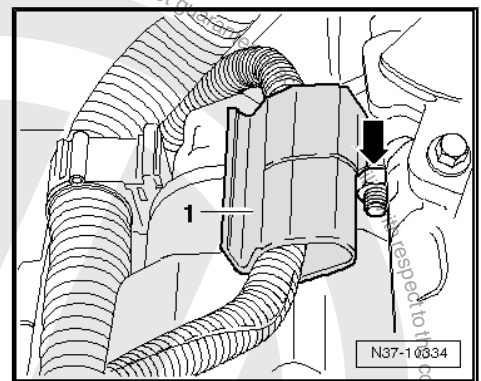

- Clamp off the coolant hoses to the transmission fluid cooler using the Hose Clamps Up to 25 mm - 3094- and the Hose Clamps Up to 40 mm - 3093- .
- Open the spring clamps -A- and remove the coolant hoses -B and C- from the cooler.
- Seal the coolant hoses and connections with plugs from the Engine Bung Set - VAS6122- .

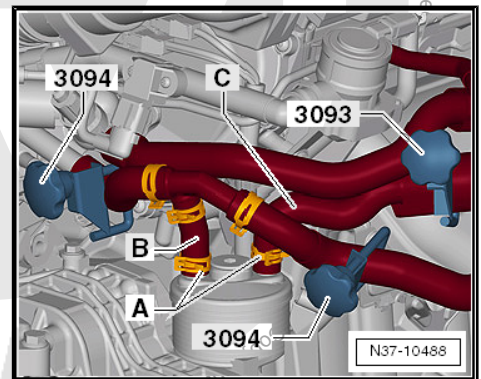



- Remove the upper transmission to engine bolts -arrows- using a 12 point swivel socket -A-.

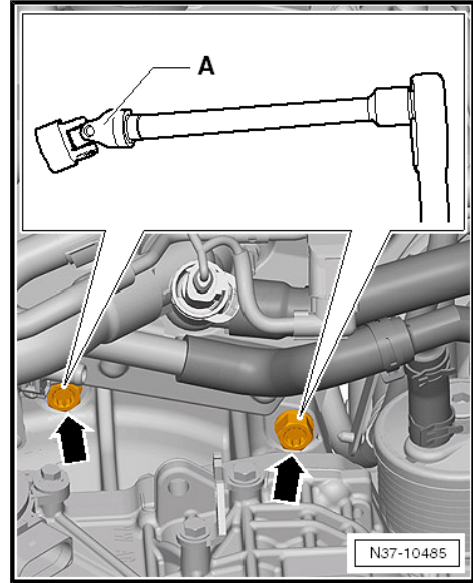

- Turn the cap -1- in the direction of the -arrow- and remove it.

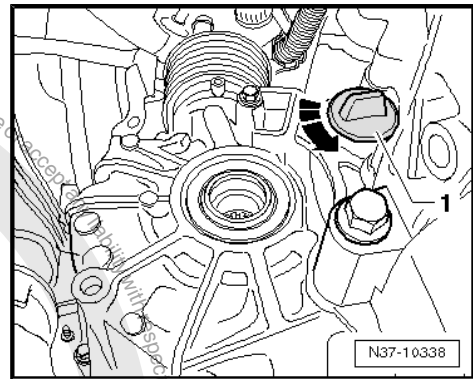

- Remove the 6 torque converter nuts using the Socket SW15 -V/175- .

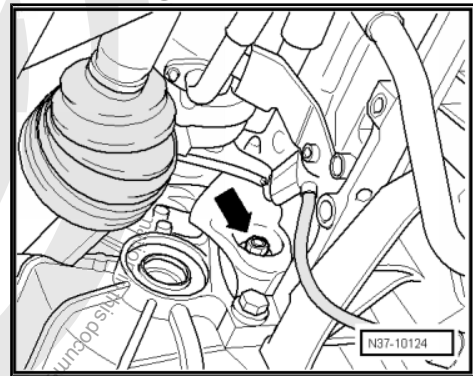

- Rotate the engine in engine rotation direction -arrow- an additional 60° turn using the Crankshaft Adapter -T03003- .



Note

- ◆ *The torque converter will be pulled out when the transmission is separated from the engine if all 6 nuts are not removed!*
- ◆ *Counter hold the vibration damper using the Crankshaft Adapter - T03003- when loosening the nuts on the torque converter.*

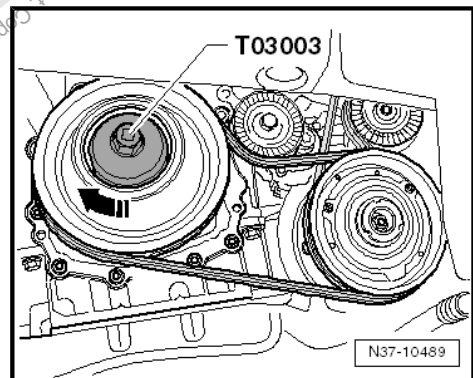



- Remove the selector lever cable bracket from the transmission.

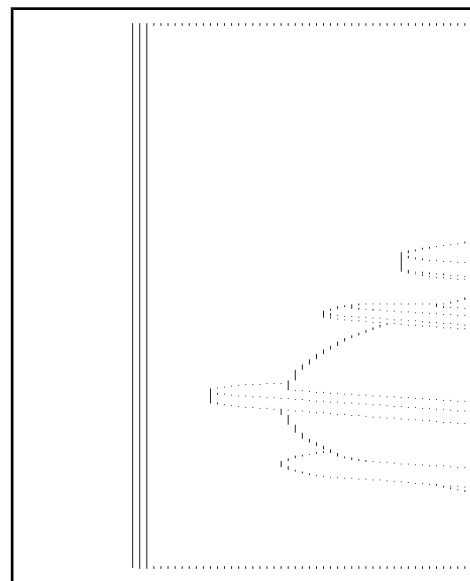

- Support the transmission using the Shop Crane - Load Cap = 700-1200 kg - VAS6100- and the Shackle - 10-222A/12- but do not lift it.
- Remove the last transmission to engine bolt.
- Separate the transmission from the engine. Push the torque converter off of the engine drive plate at the same time.

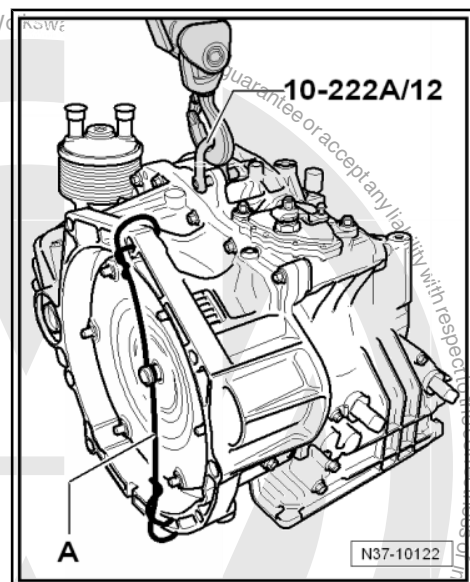

i Note

Secure the torque converter from falling out.

Assembling

Assemble in reverse order of removal. Pay attention to the tightening specifications:

- ◆ Vehicles with an automatic transmission. Refer to ⇒ Automatic Transmission; Rep. Gr. 37 ; Removal and Installation .

3.3.2 With a Manual Transmission

Special tools and workshop equipment required

- ◆ Shackle - 10-222A/12-
- ◆ Shop Crane - Load Cap = 700-1200 KG - VAS6100-
- ◆ Torque Wrench (40-200 Nm) - VAG1332-

Conditions

- The engine and transmission assembly is removed and secured to the Engine Holder Bracket - T03000- .



Caution

Note the following whenever working inside the engine compartment due to limited space:

- ◆ *Route all lines and wires in their original locations.*
- ◆ *Ensure sufficient clearance to all moving or hot components.*



Separating

- Remove the starter. Refer to ⇒ Electrical Equipment; Rep. Gr. 27 ; Removal and Installation
- Disconnect all electrical connections from the transmission to the engine and free them up.
- Support the transmission using the Shop Crane - Load Cap = 700-1200 KG - VAS6100- and the Shackles - 10-222a/12- but do not lift it.
- Remove the upper transmission to engine bolts.
- Support the transmission using the Shop Crane - Load Cap = 700-1200 KG and remove the last bolts.
- Remove the lower bolts connecting the engine and transmission.
- Separate the transmission from the engine; when doing this, guide the transmission.

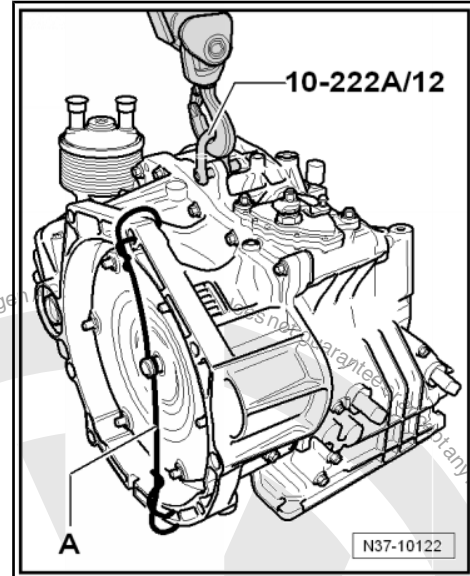

Assembling

Assemble in reverse order of removal. Pay attention to the tightening specifications:

- ◆ Vehicles with an manual transmission. Refer to ⇒ Manual Transmission; Rep. Gr. 34 ; Removal and Installation .

3.4 Engine, Securing to the Engine and Transmission Holder - VAS6095-

Special tools and workshop equipment required

- ◆ Lifting Tackle - 3033-
- ◆ Shop Crane - Load Cap = 700-1200 KG - VAS6100-
- ◆ Engine and Transmission Holder - VAS6095-
- ◆ Engine Lateral Bracket - T03001-
- ◆ Transport Arm - T03002-

When performing work, secure the engine using the Engine Lateral Bracket - T03001- to the Engine and Transmission Holder - VAS6095- .

- Remove the transmission. Refer to one of the following:
 Refer to ⇒ Manual Transmission; Rep. Gr. 34 ; Removal and Installation .
 Refer to ⇒ Automatic Transmission; Rep. Gr. 37 ; Removal and Installation .
- Pull off the clip -1- for the electric wiring harness, remove the bolts -3- and then remove the cover -2-.

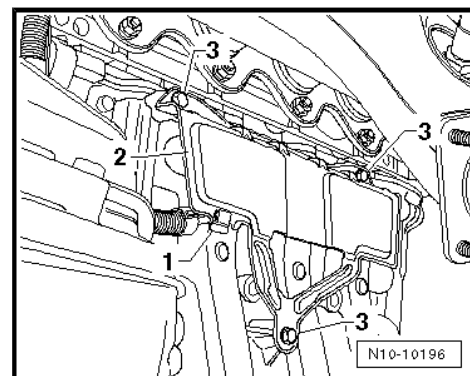



- Disconnect the harness connectors -1 and 2- and remove the bolts -arrows- at the Secondary Air Injection (AIR) valve.

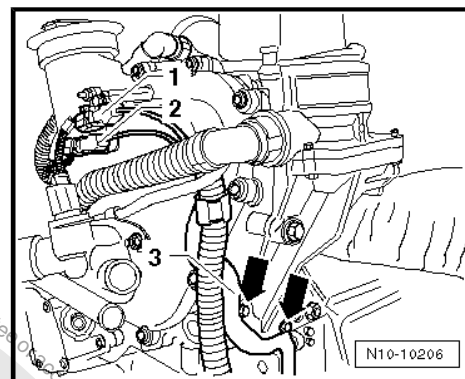

- Install the Transport Arm - T03002- as shown.

The pin -1- engages in the cylinder block. Tighten the knurled thumb screw -2- hand tight.

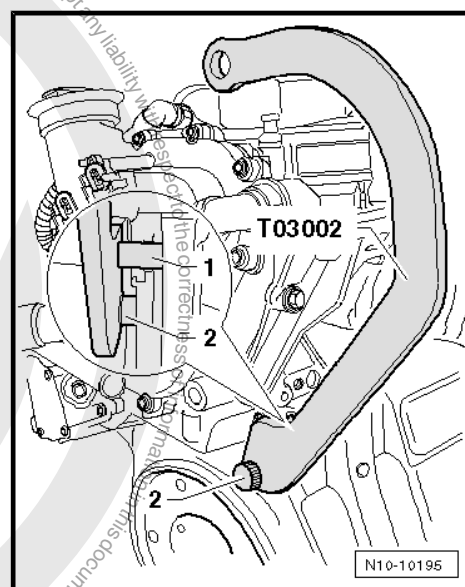

- Install the Engine Lateral Bracket - T03001- .

Tighten the bolts -1 and 3- to 40 Nm, and the bolt -2- to 25 Nm.

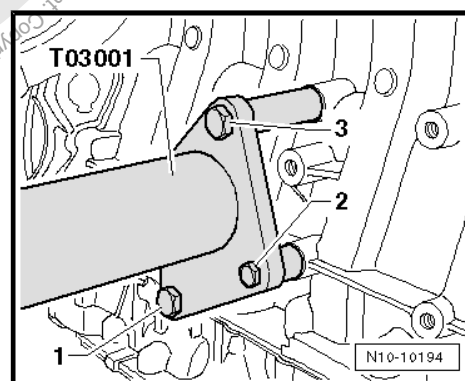

Note

- ◆ *The bolts are designed so that they cannot be lost.*
 - ◆ *When removing, the Engine Lateral Bracket - T03001- must be held tensioned in the direction of withdrawal, otherwise the bolt -1- cannot be unscrewed.*
- Install the Lifting Tackle - 3033- as shown and lift using the Shop Crane - Load Cap = 700-1200 KG - VAS6100- from the Engine-/Gearbox Jack - VAG1383A- .
 - Secure the engine to the Engine and Transmission Holder - VAS6095- .

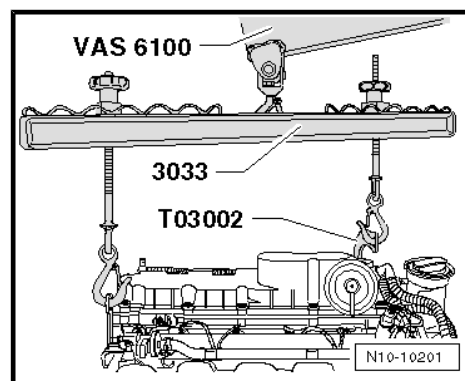



3.5 Engine, Installing

Install in reverse order of removal. Note the following:



Caution

When doing any repair work, especially in the engine compartment, pay attention to the following due to clearance issues:

- ◆ *Route all lines and wires in their original locations.*
- ◆ *To prevent damage to the lines, make sure there is sufficient clearance to all moving or hot components.*

With a Manual Transmission

- Grease the splines of the input shaft lightly with Grease For Clutch Plate Splines - G000100- .
- Install the clutch and the clutch mechanism.

Continuation for All

- Secure the engine and transmission mounts to the engine, shake the engine and transmission assembly to align it and tighten the mount bolts.



Note

- ◆ *For the engine and transmission mount tightening specifications. Refer to ⇒ ["1.1 Fastener Tightening Specifications", page 7](#) .*
- ◆ *Electrical connections and routings. Refer to ⇒ [Electrical Equipment; Rep. Gr. 97](#) .*
- Install the exhaust pipe with catalytic converter. Refer to ⇒ ["4.3 Exhaust Pipe with Catalytic Converter", page 189](#) .
- Install the right drive axle and the left drive axle to the transmission. Refer to ⇒ [Suspension; Wheels, Steering; Rep. Gr. 40 ; Removal and Installation](#) .
- Install the pendulum support. Refer to ⇒ [Suspension, Wheels, Steering; Rep. Gr. 40 ; Specifications](#) .
- Install the Air Conditioning (A/C) compressor. Refer to "Refrigerant Circuit Components" in [Heating, Ventilation and Air Conditioning; Rep. Gr. 87 ; Removal and Installation](#) .
- Install the ribbed belt. Refer to ⇒ ["5.1 Ribbed Belt", page 45](#) .
- Install the noise insulation. Refer to ⇒ [Body Exterior; Rep. Gr. 50 ; Description and Operation](#) .

With a Manual Transmission

- Install the shift mechanism and adjust if necessary. Refer to ⇒ [Manual Transmission; Rep. Gr. 34 ; Removal and Installation](#) .
- Install the clutch slave cylinder. Refer to ⇒ [Manual Transmission; Rep. Gr. 30 ; Removal and Installation](#) .

With a Automatic Transmission

- Install the selector lever cable and adjust if necessary. Refer to ⇒ [Automatic Transmission; Rep. Gr. 37 ; Removal and Installation](#) .



Continuation for All

- Fill the coolant. Refer to [⇒ "1.1 Coolant, Draining and Filling", page 121](#) .
- Install the Engine Control Module (ECM).
- Install the battery. Refer to ⇒ Electrical Equipment; Rep. Gr. 27 ; Removal and Installation .
- Adapt the ECM. Refer to "Guided Functions" in the vehicle diagnostic tester.
- Perform the vehicle system test. Refer to "Guided Fault Finding" in the vehicle diagnostic tester.
- Then, end "Guided Fault Finding".

Observe the safety precautions that apply to road tests.

- Perform a road test.
- After that perform the vehicle system test again and repair any occurring malfunctions.

Tightening Specification

Bolted Connections		Tightening specification
Bolts and nuts	M6	10 Nm
	M7	15 Nm
	M8	25 Nm
	M10	40 Nm
	M12	60 Nm





4 Special Tools

Special tools and workshop equipment required

- ◆ Hose Clip Pliers - VAS6340-
- ◆ Hose Clip Pliers - VAS6362-
- ◆ Engine-/Gearbox Jack - VAG1383A-
- ◆ Tensioning Strap - T10038-
- ◆ Step Ladder - VAS5085-
- ◆ Engine Holder Bracket - T03000-

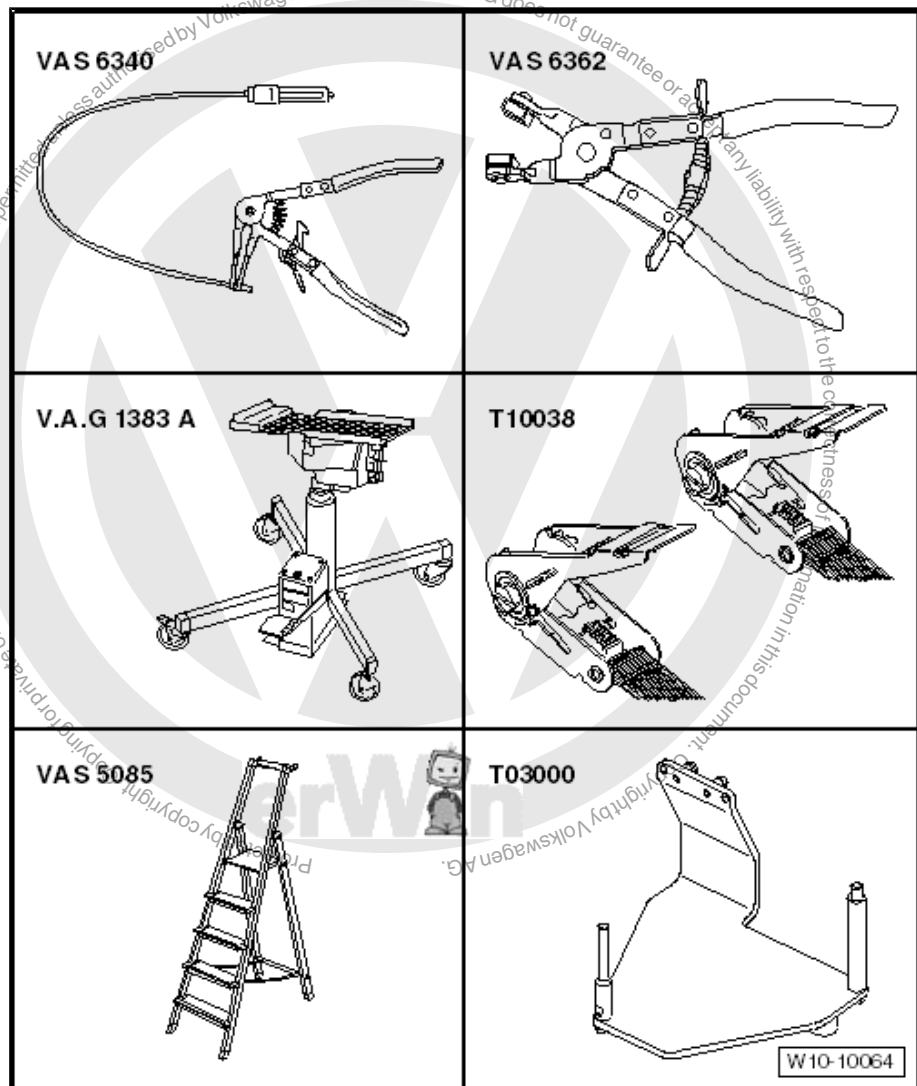



- ◆ Lifting Tackle - 3033-
- ◆ Shop Crane - Load Cap = 700-1200 KG - VAS6100-
- ◆ Engine and Transmission Holder - VAS6095-
- ◆ Engine Lateral Bracket - T03001-
- ◆ Transport Arm - T03002-

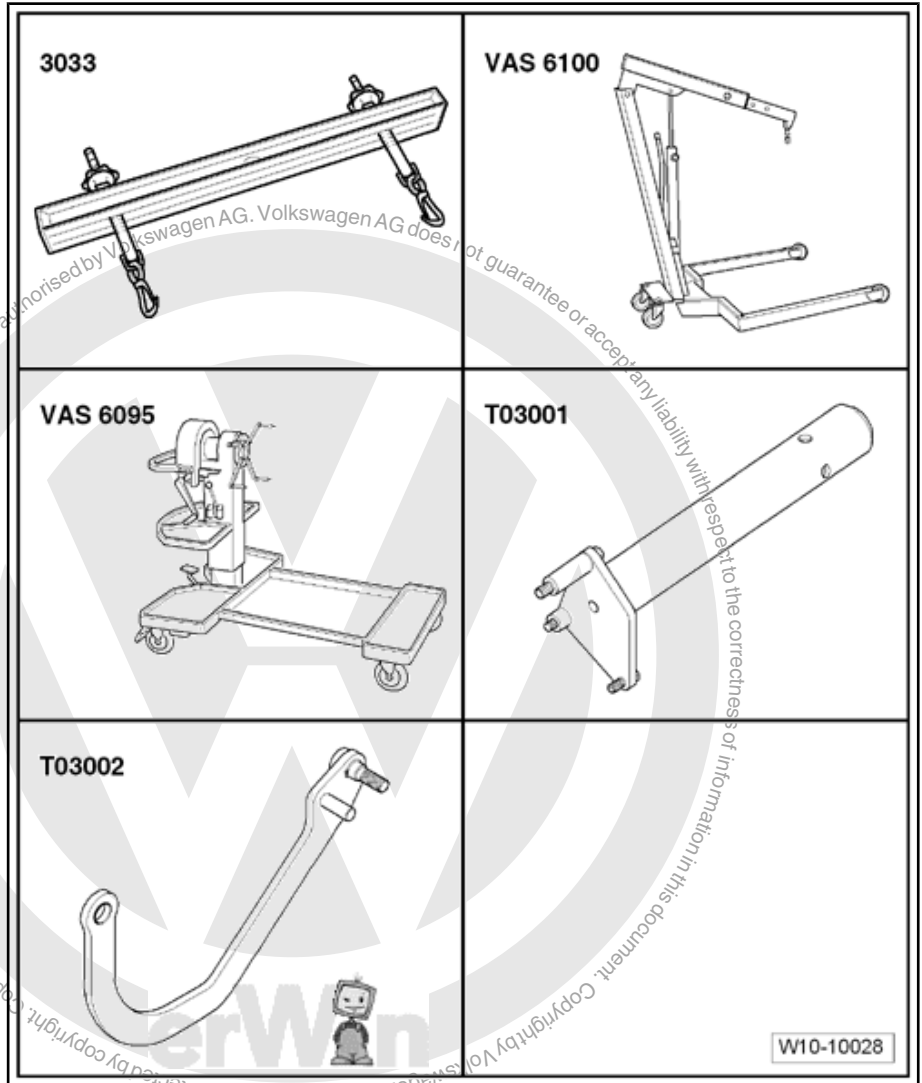

- ◆ Crankshaft Adapter - T03003-

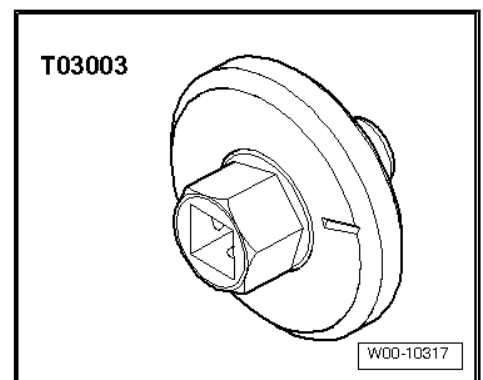



- ◆ Torque Wrench (40-200 Nm) - VAG1332-

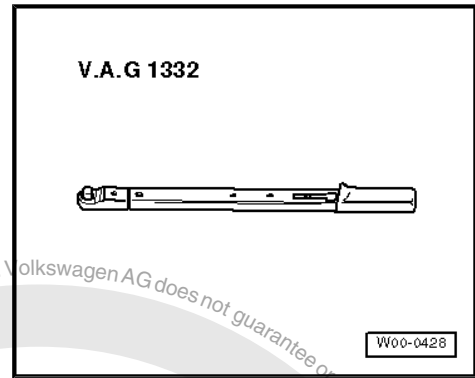

- ◆ Socket SW15 - V/175-

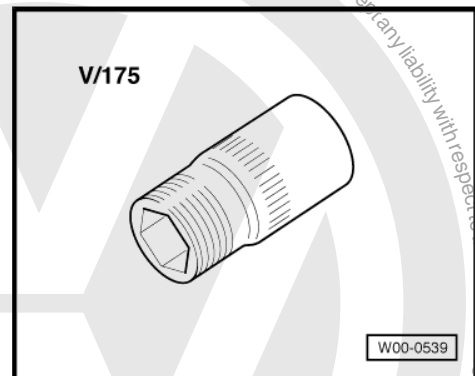

- ◆ Shackle - 10-222A/12-

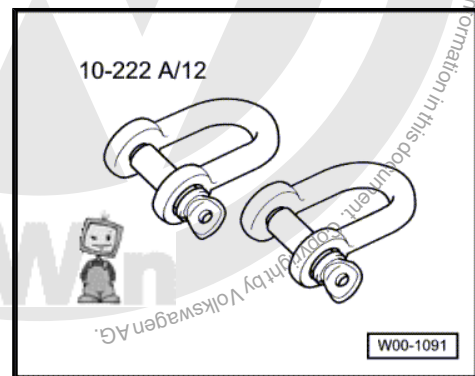

- ◆ Hose Clamps up to 40 mm - 3093-

- ◆ Hose Clamps up to 25 mm - 3094-

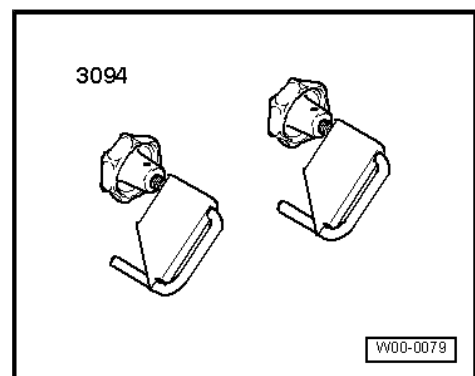



13 – Crankshaft, Cylinder Block

1 General Information

⇒ ["1.1 New Connecting Rod, Separating", page 25](#)

1.1 New Connecting Rod, Separating

New connecting rods may not be separated at the location where they should be. If the connecting rod bearing cap cannot be removed by hand, proceed as follows:

- Mark which cylinder the connecting rod belongs to.
- Lightly clamp the connecting rod in a vise equipped with aluminum protective jaw pads.



Note

- ◆ Only clamp the connecting rod lightly to avoid damaging it.
- ◆ Clamp the connecting rod below the dotted line.
- Loosen both bolts -arrows- about five turns.
- Carefully tap against the connecting rod bearing cap in the direction of the -arrow- with a plastic hammer until the cap is loose.

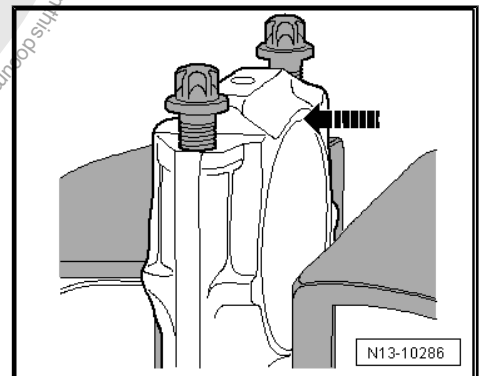
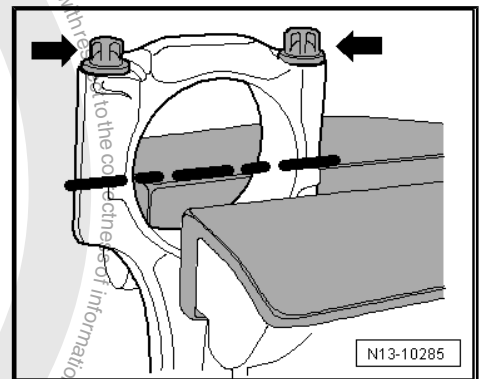



2 Description and Operation

Engine Codes BGP and BGQ

⇒ ["2.1 Ribbed Belt Overview", page 26](#)

Engine Codes CBTA and CBUA

⇒ ["2.2 Ribbed Belt Drive Overview", page 28](#)

⇒ ["2.3 Engine Overview, Rear", page 30](#)

⇒ ["2.4 Engine Overview, Front/Side", page 32](#)

⇒ ["2.5 Sealing Flange and Drive Plate/Flywheel Overview", page 33](#)

⇒ ["2.6 Flywheel Overview", page 34](#)

⇒ ["2.7 Crankshaft Overview", page 35](#)

⇒ ["2.8 Crankshaft, Locking", page 36](#)

⇒ ["2.9 Pistons and Connecting Rod Overview", page 38](#)

2.1 Ribbed Belt Overview

1 - Bolt

- 25 Nm

2 - Bolt

- 25 Nm

3 - Generator

- Removing and installing. Refer to ⇒ Electrical Equipment; Rep. Gr. 27 ; Removal and Installation .
- To make it easier to position the generator, drive the threaded bushing for the generator bolt back slightly.

4 - Bolt

- 25 Nm

5 - Lower Idler Pulley with Bracket

- For the Air Conditioning (A/C) compressor ribbed belt.
- Do not remove the pulley.

6 - Bolt

- 25 Nm

7 - A/C Compressor

- Removing and installing. Refer to "Refrigerant Circuit Components" in ⇒ Heating, Ventilation and Air Conditioning; Rep. Gr. 87 ; Removal and Installation .

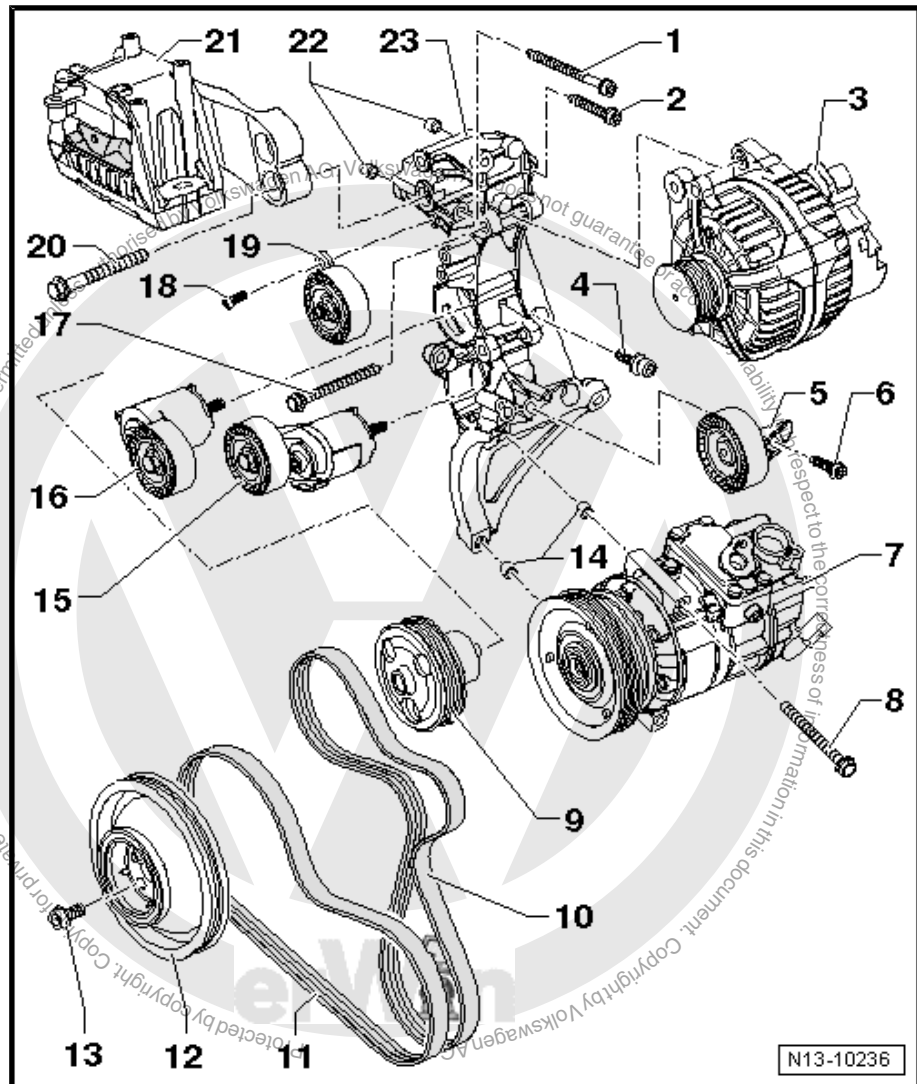

N13-10236



8 - Bolt

- 25 Nm

9 - Coolant Pump

- In the cylinder block.
- Removing and installing. Refer to ⇒ [“4.2 Coolant Pump”, page 135](#) .

10 - Ribbed Belt, Generator, Power Steering Pump and Coolant Pump

- Belt routing. Refer to ⇒ [Fig. “Belt Routing”](#) , page 28 .
- Before removing, mark the rotation direction using chalk or a felt tip pen.
- Check for wear.
- Do not kink.
- Removing and installing. Refer to ⇒ [“5.1 Ribbed Belt”, page 45](#) .

11 - Ribbed Belt, A/C Compressor

- Belt routing. Refer to ⇒ [Fig. “Belt Routing”](#) , page 28 .
- Before removing, mark the rotation direction using chalk or a felt tip pen.
- Check for wear.
- Do not kink.
- Removing and installing. Refer to ⇒ [“5.1 Ribbed Belt”, page 45](#) .

12 - Vibration Damper

- To remove and install, lock the crankshaft. Refer to ⇒ [“2.8 Crankshaft, Locking”, page 36](#) .

13 - Bolt

- 50 Nm + an additional 90° (1/4 turn).
- Always replace.
- Only use strength category 10.9 bolts.
- Quantity: 5

14 - Bushing

- Quantity: 2

15 - Ribber Belt Tensioner, A/C Compressor Belt

- 35 Nm
- Do not remove the tensioning roller, remove the entire tensioner. Refer to ⇒ [“5.2 Ribbed Belt Tensioner, A/C Compressor”, page 46](#) .

16 - Ribbed Belt Tensioner, Generator, Power Steering Pump and Coolant Pump Belt

- 35 Nm
- Do not remove the tensioning roller, remove the entire tensioner. Refer to ⇒ [“5.3 Ribbed Belt Tensioner, Generator, Power Steering Pump and Coolant Pump”, page 47](#) .

17 - Bolt

- 25 Nm

18 - Bolt

- 8 Nm

19 - Upper Idler Pulley with Bracket

- For the generator, power steering pump and coolant pump ribbed belt.
- Do not remove the pulley.

20 - Bolt

- 40 Nm + an additional 90° (1/4) turn.

21 - Engine Mount

22 - Bushing

- Quantity: 2

23 - Accessory Bracket



Belt Routing

- 1 - Upper idler pulley
- 2 - Generator
- 3 - Lower idler pulley
- 4 - Ribbed belt, generator, power steering pump and coolant pump
- 5 - A/C compressor
- 6 - Ribbed belt, A/C compressor
- 7 - Vibration damper
- 8 - Belt tensioner, A/C compressor ribbed belt
- 9 - Belt tensioner, generator, power steering pump and coolant pump ribbed belt
- 10 - Coolant pump

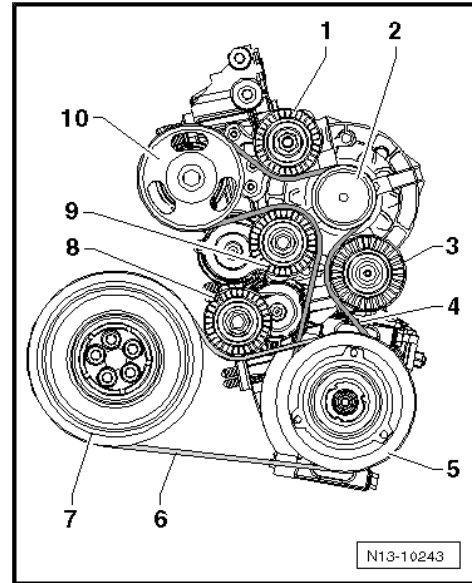

2.2 Ribbed Belt Drive Overview

- 1 - Bolt**
 - 25 Nm
- 2 - Bolt**
 - 25 Nm
- 3 - Generator**
 - Removing and installing. Refer to ⇒ Electrical Equipment; Rep. Gr. 27 ; Removal and Installation .
 - To make it easier to position the generator, drive the threaded bushing for the generator bolt back slightly.
- 4 - Bolt**
 - 25 Nm
- 5 - Lower Idler Pulley with Bracket**
 - For the Air Conditioning (A/C) compressor, ribbed belt
 - Do not remove the pulley.
- 6 - Bolt**
 - 25 Nm
- 7 - A/C Compressor**
 - Removing and installing. Refer to "Refrigerant Circuit Components" in ⇒ Heating, Ventilation and Air Conditioning; Rep. Gr. 87 ; Removal and Installation .

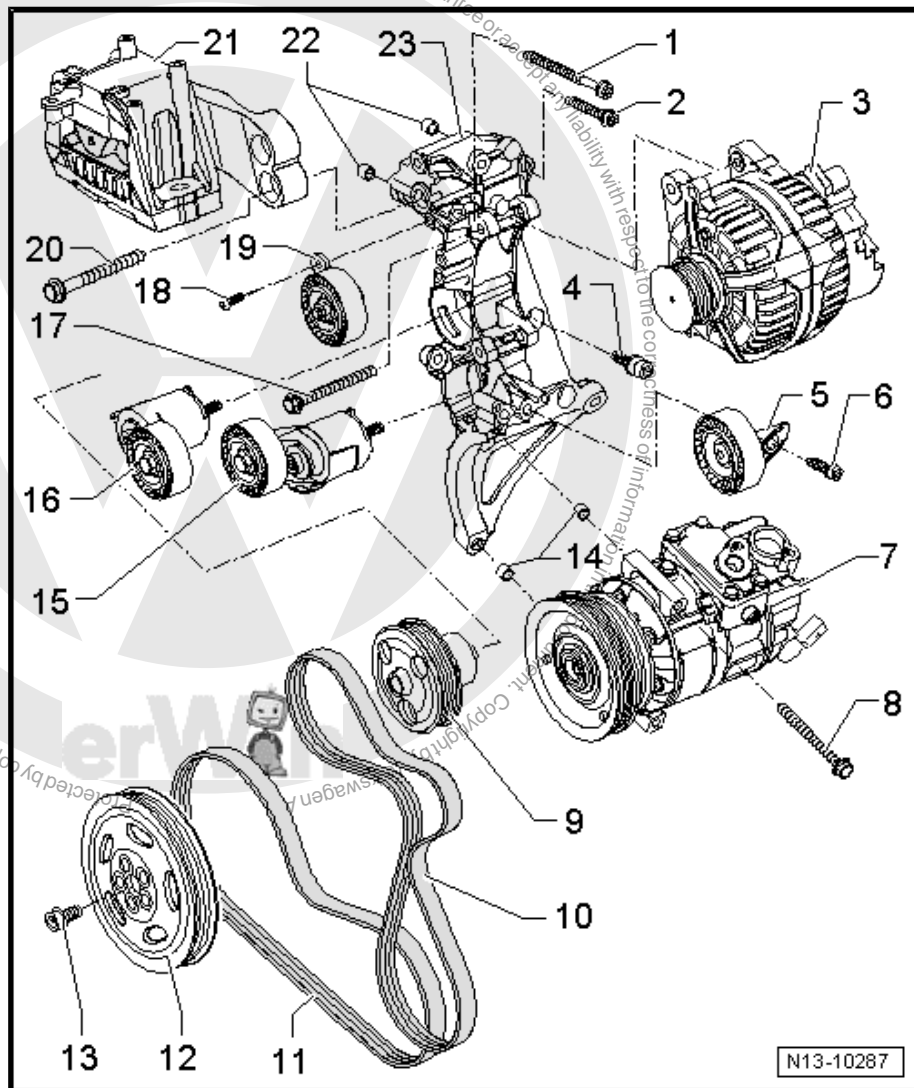



8 - Bolt

- 25 Nm

9 - Coolant Pump

- In the cylinder block.
- Removing and installing. Refer to ⇒ [“4.2 Coolant Pump”, page 135](#) .

10 - Ribbed Belt, Generator, Power Steering Pump and Coolant Pump

- Belt routing. Refer to ⇒ [Fig. “Belt Routing”](#) , page 30 .
- Before removing, mark the rotation direction using chalk or a felt tip pen.
- Check for wear.
- Do not kink.
- Removing and installing. Refer to ⇒ [“5.1 Ribbed Belt”, page 45](#) .

11 - Ribbed Belt, A/C Compressor

- Belt routing. Refer to ⇒ [Fig. “Belt Routing”](#) , page 30 .
- Before removing, mark the rotation direction using chalk or a felt tip pen.
- Check for wear.
- Do not kink.
- Removing and installing. Refer to ⇒ [“5.1 Ribbed Belt”, page 45](#) .

12 - Vibration Damper

- There are different versions
- To remove and install, lock secure the crankshaft. Refer to ⇒ [“2.8 Crankshaft, Locking”, page 36](#) .

13 - Bolts

- 50 Nm + an additional 90° (1/4) turn.
- Always replace.
- Use a strength category 10.9 bolt only.
- Quantity: 5

14 - Bushing

- Quantity: 2

15 - Belt Tensioner, A/C Compressor

- 35 Nm
- Do not remove the tensioning roller, remove the entire tensioner. Refer to ⇒ [“5.2 Ribbed Belt Tensioner, A/C Compressor”, page 46](#) .

16 - Belt Tensioner, Generator, Power Steering Pump and Coolant Pump

- 35 Nm
- Do not remove the tensioning roller, remove the entire tensioner. Refer to ⇒ [“5.3 Ribbed Belt Tensioner, Generator, Power Steering Pump and Coolant Pump”, page 47](#) .

17 - Bolt

- 25 Nm

18 - Bolt

- 8 Nm

19 - Upper Idler Pulley with Bracket

- For the generator, power steering pump and coolant pump ribbed belt.
- Do not remove the pulley.

20 - Bolt

- 40 Nm + an additional 90° (1/4) turn.

21 - Engine Mount

22 - Bushing

- Quantity: 2



23 - Accessory Bracket

Belt Routing

- 1 - Upper idler pulley
- 2 - Generator
- 3 - Lower idler pulley
- 4 - Ribbed belt, generator, power steering pump and coolant pump
- 5 - A/C compressor
- 6 - Ribbed belt, A/C compressor
- 7 - Vibration Damper
- 8 - Belt tensioner, A/C compressor ribbed belt
- 9 - Belt tensioner, generator, power steering pump and coolant pump ribbed belt
- 10 - Coolant pump

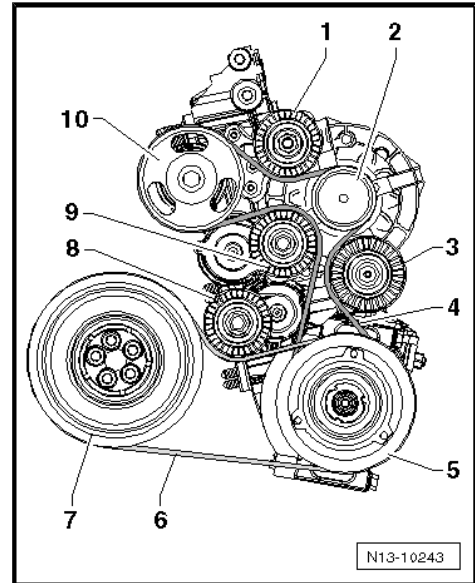

2.3 Engine Overview, Rear

1 - Cylinder Block

2 - Locking Bolt

- 30 Nm
- With a rolled seal.
- The bore in the cylinder block is used for locking the crankshaft using the Locking Pin - T40069- .

3 - Knock Sensor 1 - G61-

- Note the installed position: The wire connection points downward vertically.

4 - Bolt

- 20 Nm
- Tightening specification affects the function of the knock sensor.

5 - Bolt

- 10 Nm

6 - Cover

7 - Plug

8 - Wire Clip

- Clipped to the cover plate.

9 - Knock Sensor 2 - G66-

- Note the installed position: The wire connection points 45° toward the right on the outside.

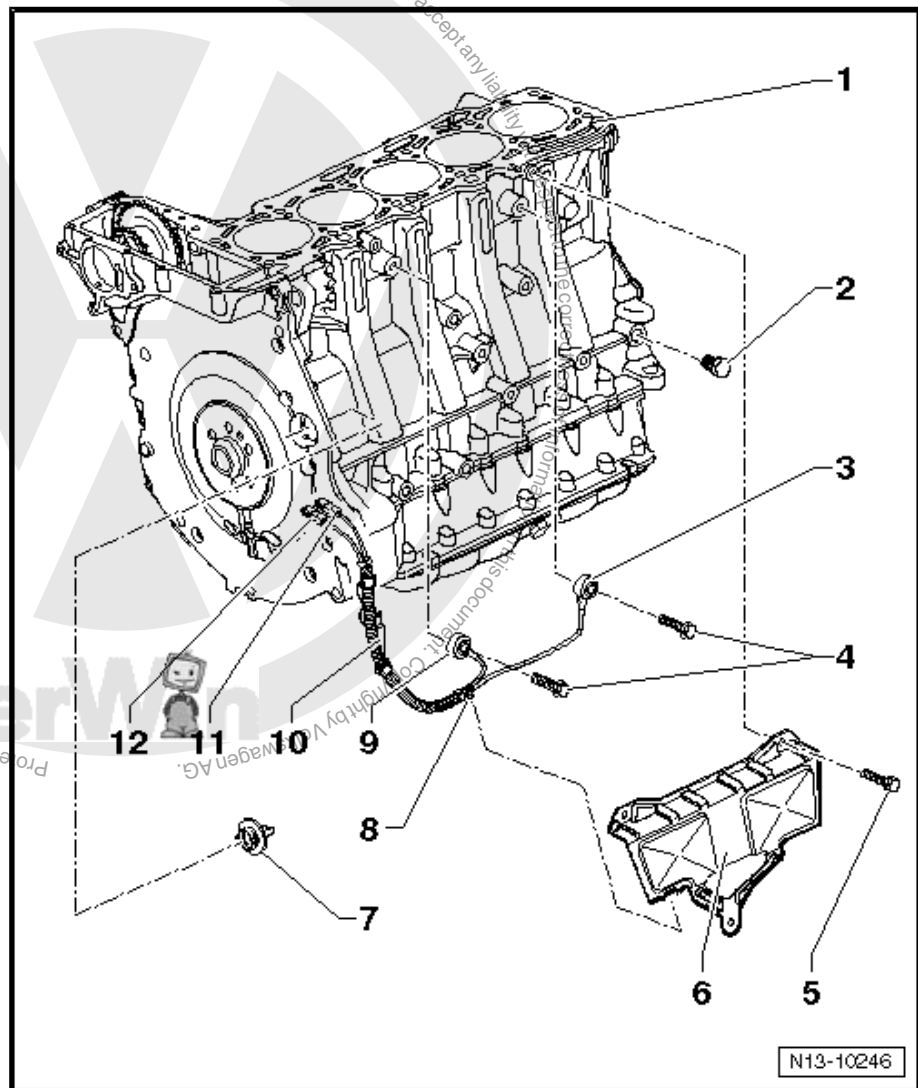



10 - Wire Bracket

- Bolted to the Secondary Air Injection (AIR) valve.

11 - Connector

- Green for knock sensor 1.
- Installed position. Refer to [⇒ Fig. "Installed Position of the Knock Sensor Harness Connectors" , page 31](#) .
- Contacts are gold plated.

12 - Connector

- Gray for knock sensor 2.
- Installed position. Refer to [⇒ Fig. "Installed Position of the Knock Sensor Harness Connectors" , page 31](#) .
- Contacts are gold plated.

Installed Position of the Knock Sensor Harness Connectors

- 1 - Green for knock sensor 1
- 2 - Gray for knock sensor 2

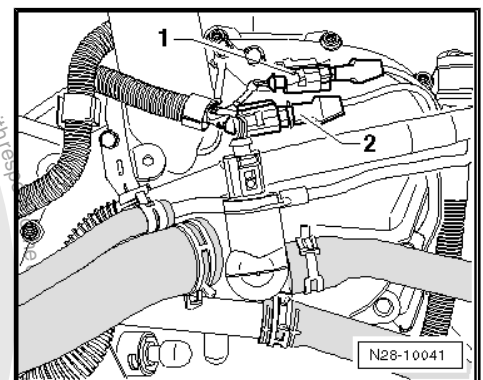



2.4 Engine Overview, Front/Side

1 - Cylinder Block

2 - Gasket

- Always replace.

3 - Brake Booster Vacuum Pump

- Do not open.
- Removing and installing. Refer to ["4.3 Vacuum Pump", page 84](#).

4 - Bracket

5 - Bolt

- 10 Nm

6 - Oil Filter Adapter

- Overview. Refer to ["2.2 Oil Filter Adapter Overview", page 104](#).

7 - Bolt

- 25 Nm

8 - Nut

- 10 Nm

9 - Bolt

- 10 Nm

10 - Thermostat Housing

- With thermostat and coolant pipe.

11 - Bolt

- 10 Nm

12 - Intake Manifold Support

- Only for engines with a Secondary Air Injection (AIR) system.

13 - Bolt

- 25 Nm

14 - Bolt

- 10 Nm

15 - Bolt

- 25 Nm

16 - Accessory Bracket

17 - Bolt

- 40 Nm + an additional 90° (1/4) turn.

18 - Engine Mount

19 - Guide Tube

- For the oil dipstick.

20 - Bracket

21 - Bolt

- 25 Nm

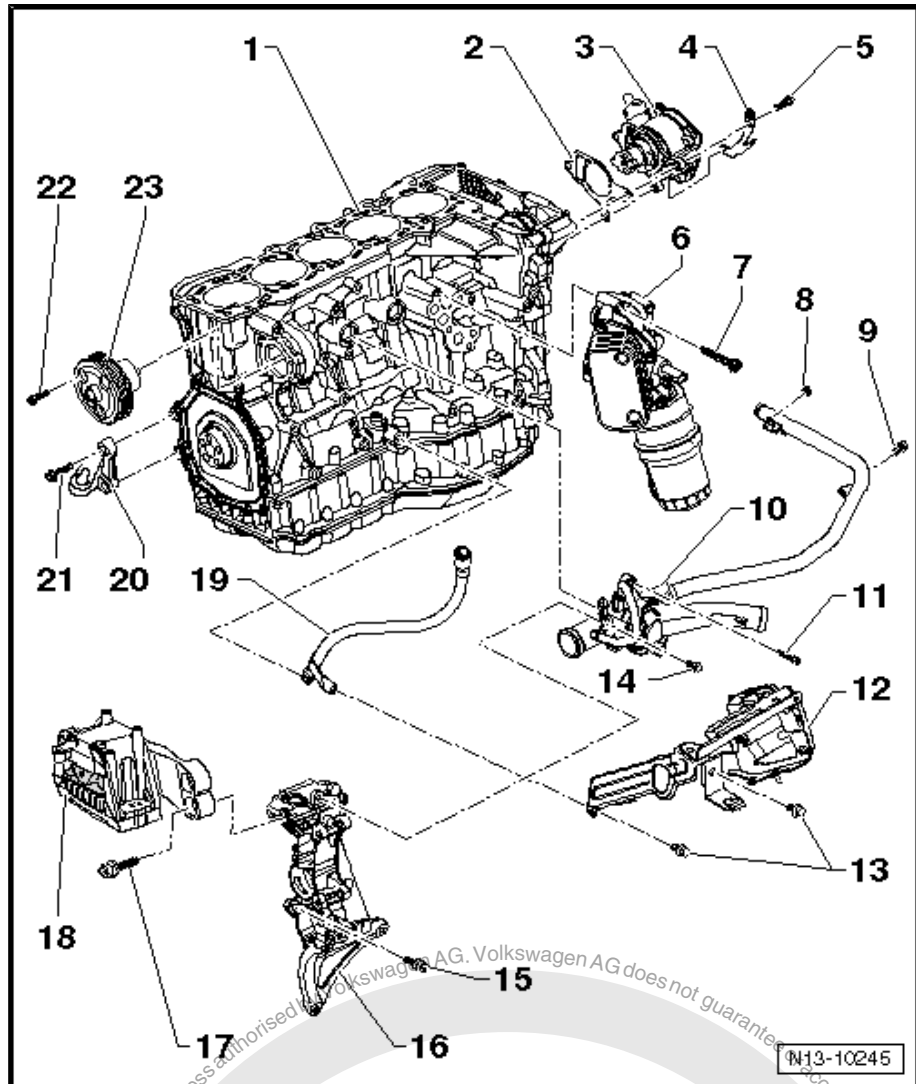



22 - Bolt

- 10 Nm

23 - Coolant Pump

- Removing and installing. Refer to ["4.2 Coolant Pump", page 135](#) .

2.5 Sealing Flange and Drive Plate/Flywheel Overview

1 - Vibration Damper

- There are different versions.

2 - Bolts

- 50 Nm + an additional 90° (1/4) turn.
- Always replace.
- Use a strength category 10.9 bolt only.
- Quantity: 5

3 - Bolt

- 10 Nm

4 - Sealing Flange, Belt Pulley Side

- With an integrated seal.
- Removing and installing. Refer to ["5.5 Sealing Flange, Belt Pulley Side", page 49](#) .

5 - Cylinder Block

6 - Bolt

- 60 Nm + an additional 90° (1/4) turn.
- Always replace.

7 - Drive Plate/Flywheel

- ◆ To remove, lock the crankshaft using the Locking Pin - T40069- .
- ◆ The flywheel must not be pried out or the sealing flange will be damaged.

- Drive plate removing and installing. Refer to ["5.7 Drive Plate", page 53](#) .
- Flywheel removing and installing. Refer to ["5.8 Flywheel", page 54](#) .

8 - Sensor Wheel

- For the engine speed sensor.
- With a position holder.

9 - Seal, Transmission Side

- Removing and installing. Refer to ["5.6 Seal, Transmission Side", page 52](#) .

10 - Sealing Flange, Transmission Side

- Removing and installing. Refer to ["5.9 Sealing Flange, Transmission Side", page 54](#) .

11 - O-Ring

- Always replace.

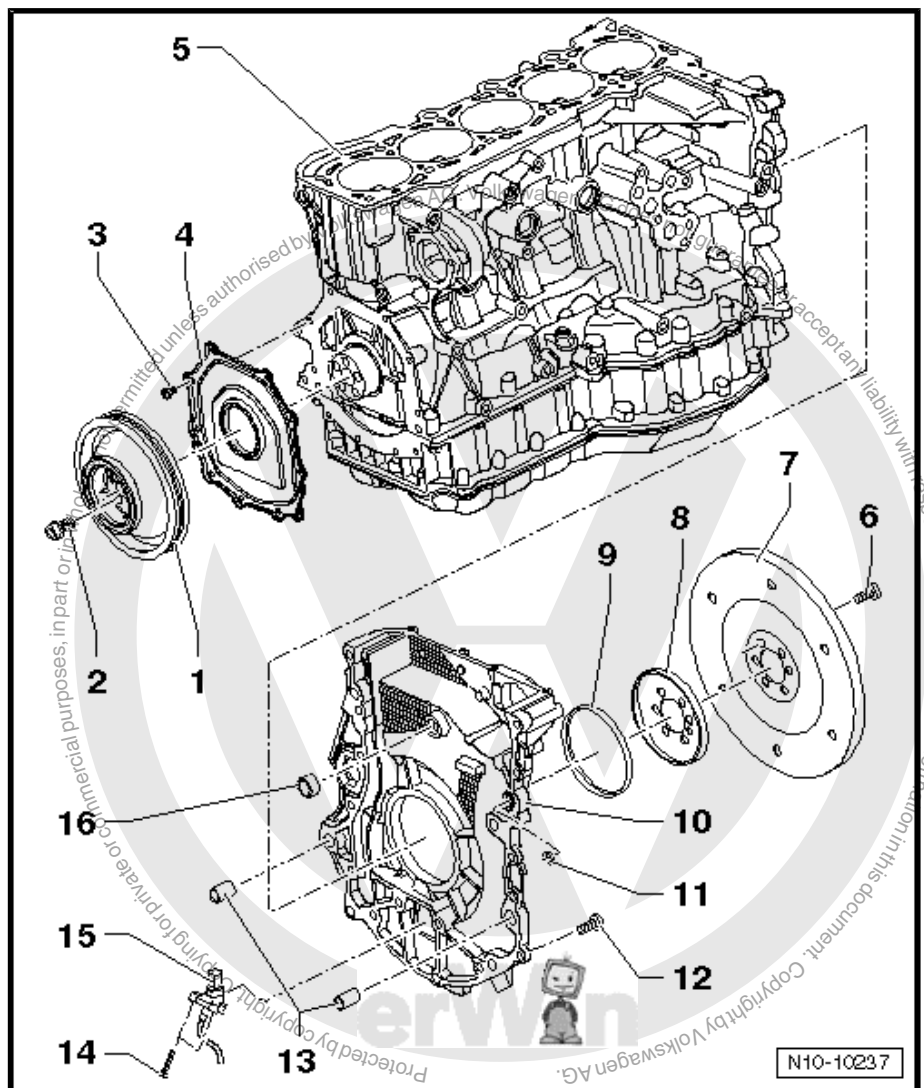



12 - Bolt

- 25 Nm

13 - Alignment Sleeves

14 - Bolt

- 5 Nm

15 - Engine Speed Sensor - G28-

16 - Seal

- Always replace.

2.6 Flywheel Overview



Note

Servicing the clutch. Refer to ⇒ Manual Transmission; Rep. Gr. 30.

1 - Flywheel

2 - Bolts

- 60 Nm + an additional 90° (1/4) turn.
- Always replace.

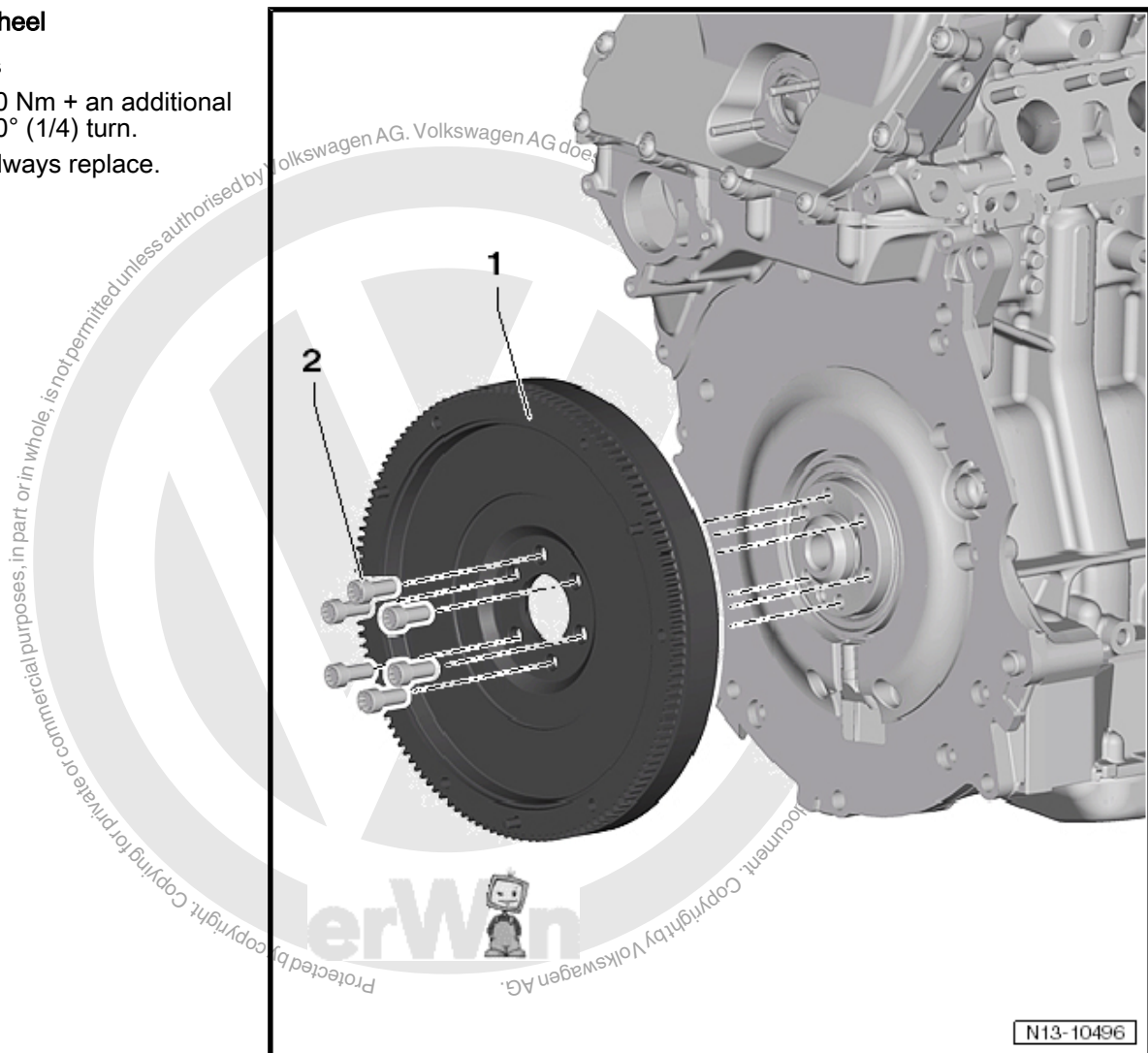



2.7 Crankshaft Overview

1 - Bolt

- 40 Nm + an additional 90° (1/4) turn.
- Tighten to 40 Nm (but not the additional 90°) to measure the radial play in the crankshaft.
- Always replace.
- Fully threaded.

2 - Bearing Cap

- Bearing cap 1: Belt pulley side
- Retaining tabs on the bearing shells and cylinder block/bearing caps must align with one another.

3 - Bearing Shell for the Bearing Cap

- Crankshaft bearing shell, allocating. Refer to [Fig. "Allocation, Lower Bearing Shells \(Bearing Cap\)", page 36](#).
- Without a lubricating groove.
- Do not interchange used bearing shells (mark them).

4 - Crankshaft

- Axial play, checking. Refer to ["4.1 Crankshaft Axial Clearance, Checking", page 42](#).

- Radial clearance, checking. Refer to ["4.2 Crankshaft Radial Clearance, Checking", page 42](#).
- Crankshaft dimensions. Refer to ["3.1 Crankshaft Dimensions", page 41](#).
- Locking the crankshaft. Refer to ["2.8 Crankshaft, Locking", page 36](#).

5 - Thrust Washers

- For bearing 3.
- The side lubricating grooves face outward.

6 - Bearing Shell for the Cylinder Block

- With a lubricating groove.
- Crankshaft bearing shell, allocating. Refer to ["Allocation, Upper Bearing Shells \(Cylinder Block\)", page 36](#).
- Do not interchange used bearing shells (mark them).

7 - Cylinder Block

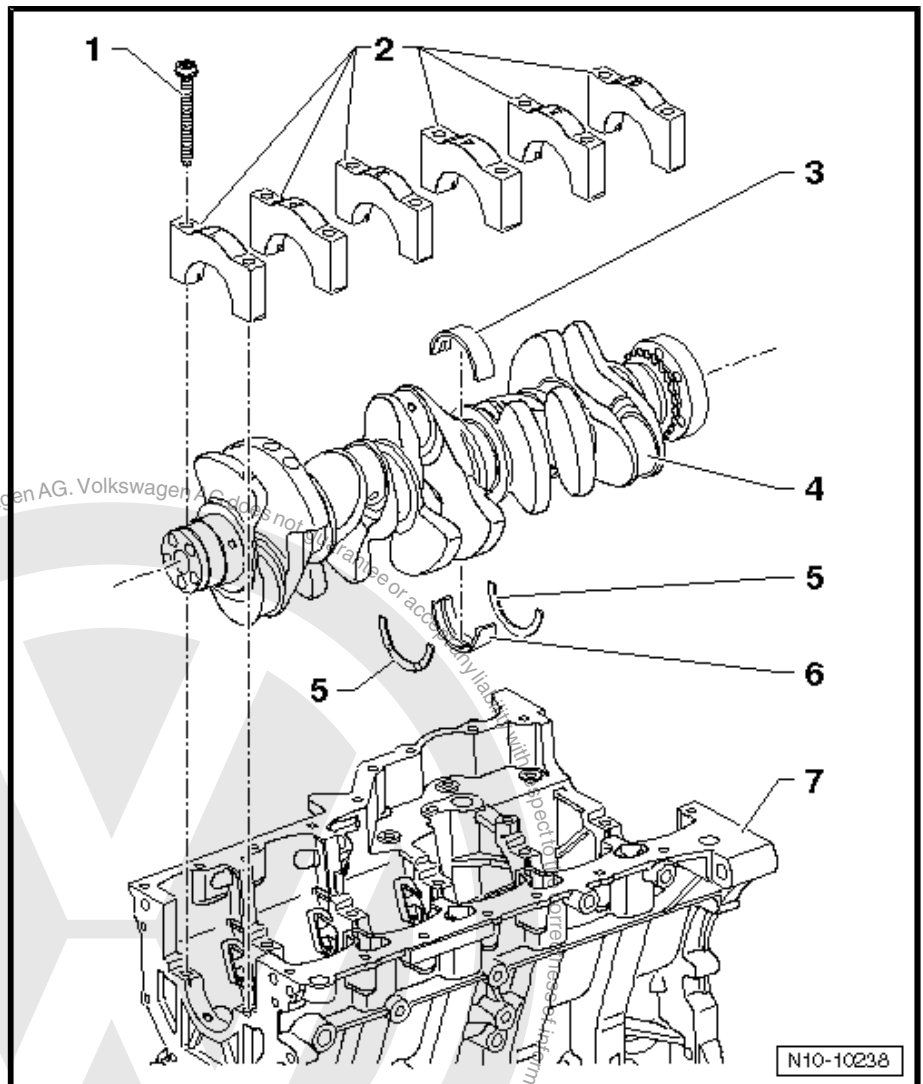



Allocation, Upper Bearing Shells (Cylinder Block)

From the factory, the upper bearing shells are allocated to the cylinder block with the correct thickness. Colored dots serve to identify the bearing thicknesses.

The letters marked on the lower sealing surface of the cylinder block identify which bearing thickness must be installed in which location.

Letter on Cylinder Block	Colored Dot on the Bearing Shell
G =	Yellow
B =	Blue
R =	Red

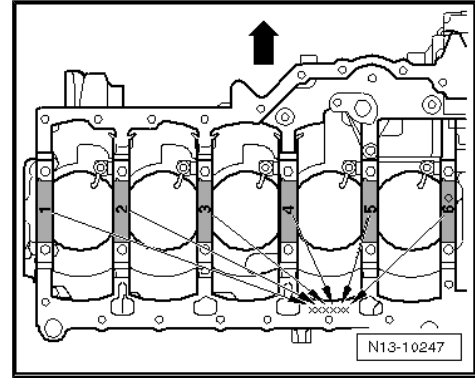

Note

- ◆ The -arrow- points in the direction of travel.
- ◆ If the colored dot is not visible, use the blue bearing shell.

Allocation, Lower Bearing Shells (Bearing Cap)

◆ From the factory, the lower bearing shells are allocated to the bearing cap with the correct thickness. Colored dots on the sides of the bearing shells serve to identify bearing shell thickness.

◆ The allocation of the bearing shells for the bearing cap is identified by a series of letters on the vibration damper. The first letter in the row of letters represents bearing "1", the second letter is for bearing "2", etc.

Letter on Vibration Damper	Colored Dot
R =	Red
G =	Yellow
B =	Blue
W =	White

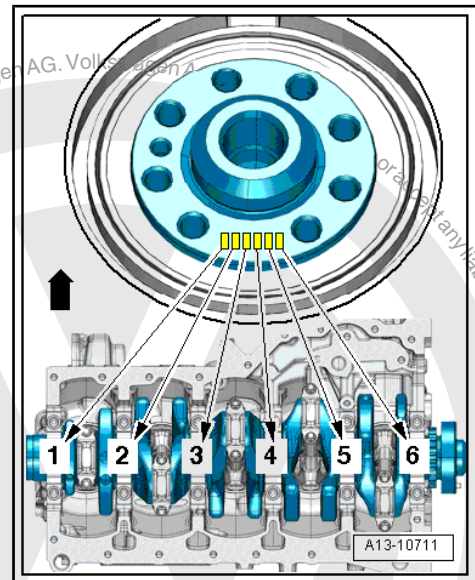

Note

The -arrow- points in the direction of travel.

2.8 Crankshaft, Locking

Special tools and workshop equipment required

- ◆ Torque Wrench (5-50 Nm) - VAG1331-
- ◆ Crankshaft Adapter - T03003-
- ◆ Locking Pin - T40069-

Procedure

- Remove the noise insulation. Refer to ⇒ Body Exterior; Rep. Gr. 50 ; Description and Operation .
- Remove the front section of the right wheel housing liner. Refer to ⇒ Body Exterior; Rep. Gr. 66 ; Removal and Installation .



- Install the Crankshaft Adapter - T03003- onto the bolts of the vibration damper.

The Crankshaft Adapter - T03003- can only be installed correctly in one position.

- Rotate the crankshaft in engine rotation direction until the arrow -A- on the Crankshaft Adapter - T03003- faces downward vertically in comparison to the engine axis.

This position corresponds approximately to the Top Dead Center (TDC) position of the crankshaft at cylinder 5.

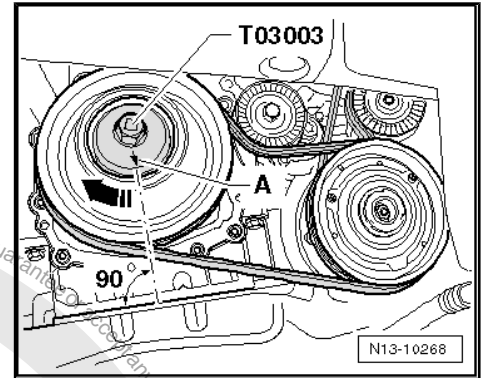

- Remove the locking bolt -1- from the rear of the cylinder block.
 - Look through the threaded hole and check whether the bore -2- in the crankshaft aligns with the threaded hole.
- Use a mirror to do so, if necessary.
- Rotate the crankshaft slightly if necessary.
 - If the bore and the hole align, install the Locking Pin - T40069- completely into the threaded hole and tighten it to 10 Nm.

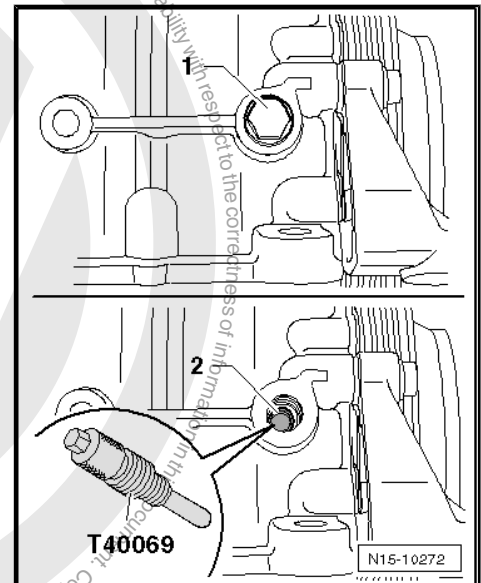

i Note

With the engine removed, the TDC mark can also be seen on the vibration damper and sealing flange. The notches -A and B- must align.

- Check whether the crankshaft can be rotated.

After Disassembly and Assembly Work

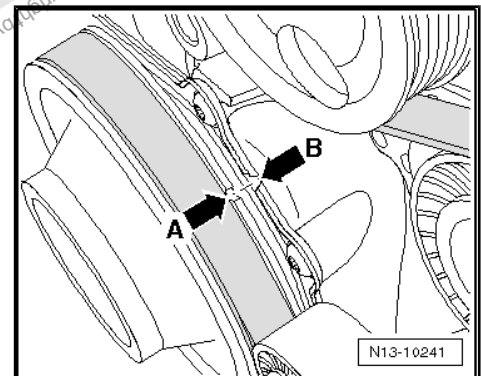



- Remove the Locking Pin - T40069- and install the locking bolt -1- .

The rest of the installation follows the reverse of the removal procedure.

Tightening Specifications

Component	Nm
Locking bolt to rear of cylinder block	30 Nm

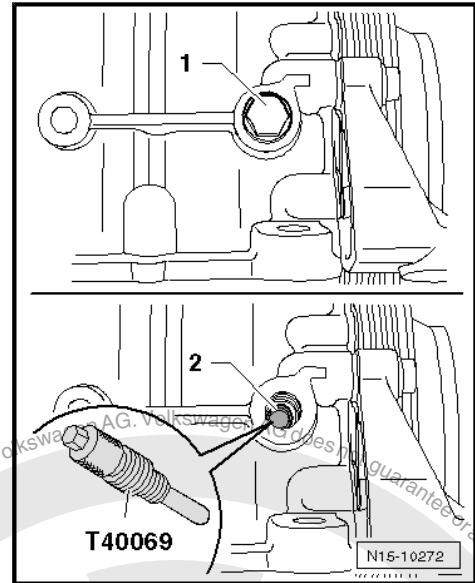

2.9 Pistons and Connecting Rod Overview



Note

The engine is to be secured to the Engine Lateral Bracket - T03001- when performing assembly work.



1 - Bolt

- 30 Nm + an additional 90° (1/4) turn.
- Tighten to 30 Nm to measure radial play, do not tighten the additional 90° turn.
- Always replace.
- Lubricate the threads and contact surface.

2 - Pressure Relief Valve

- 27 Nm
- Opening pressure: 1.3 to 1.6 bar (18.85 to 23.2 psi) excess pressure.

3 - Oil Spray Jet

- For piston cooling.

4 - Connecting Rod Bearing Cap

- Pay attention to the installed position.
- Due to the separation procedure (cracking) for the connecting rod, the connecting rod bearing cap only fits in one position and only on the appropriate connecting rod.
- Mark which cylinder the cap belongs to.
- Installed position: the marks -A- point to the belt pulley side.

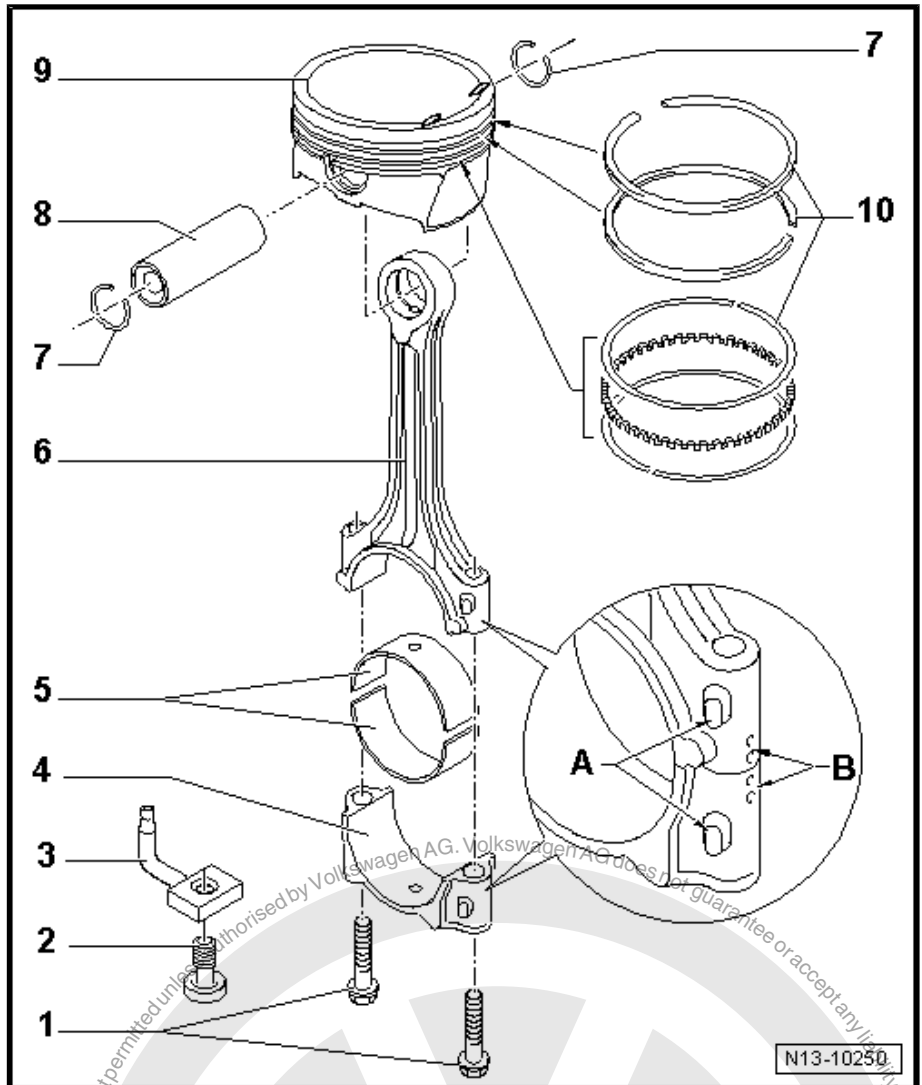

5 - Bearing Shell

- Note the installed position. Refer to ⇒ [Fig. "Bearing Shell Installed Position"](#) , page 40 .
- Do not interchange used bearing shells (mark them).
- Axial play:
 New: 0.10 to 0.35 mm
 Wear limit: 0.4 mm
- Measure radial clearance using Plastigage®:
 New: 0.02 to 0.06 mm
 Wear limit: 0.09 mm
- Do not rotate the crankshaft when measuring radial play.

6 - Connecting Rod

- With a cracked bearing cap.
- Separating new connecting rods. Refer to ⇒ ["1.1 New Connecting Rod Separating"](#) , page 25 .
- Always replace as a set.
- Mark which cylinder the connecting rod belongs to.
- Installed position: The marks -A- point to the belt pulley side.



7 - Circlip

8 - Piston Pin

- If difficult to move, heat the piston to 60 °C (140 °F).
- Remove and install using a Pilot Drift - VW 222 A- .

9 - Piston

- Checking. Refer to ⇒ [Fig. "Piston, Checking", page 44](#) .
- Mark the installed position and cylinder allocation.
- The arrow on the piston face points toward the belt pulley side.
- Install using a piston ring compressor.
- Piston and cylinder bore, checking. Refer to ⇒ ["4.3 Pistons and Cylinder Bore, Checking", page 43](#) .

10 - Piston Rings

- Offset gaps by 120°.
- Use piston ring pliers for removal and installation.
- Marks face toward the piston crown.
- Checking the ring gap. Refer to ⇒ [Fig. "Piston Ring Gap, Checking", page 43](#) .
- Checking the piston ring groove clearance. Refer to ⇒ [Fig. "Piston Ring Groove Clearance, Checking", page 43](#) .

Bearing Shell Installed Position

Bearing shell -1- with a connecting rod oil bore -arrow-.

Bearing shell -2- without a oil bore for the connecting rod cap.

- Place the bearing shells centrally into the connecting rod and connecting rod bearing cap.

Dimension -a- must be the same on the left and right.

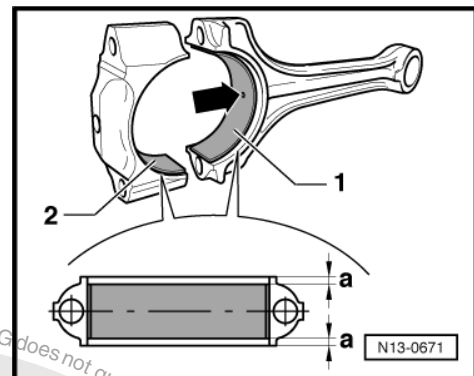



3 Specifications

⇒ **“3.1 Crankshaft Dimensions”, page 41**

3.1 Crankshaft Dimensions

(Dimensions are in mm)

Honing Dimension	Crankshaft Bearing Pin Diameter		Connecting Rod Bearing Pin Diameter	
Basic dimension	58.00	-0.022 -0.042	47.80	-0.022 -0.042
1st oversize	57.75	-0.022 -0.042	47.55	-0.022 -0.042
2nd oversize	57.50	-0.022 -0.042	47.30	-0.022 -0.042
Stage III	57.25	-0.022 -0.042	47.05	-0.022 -0.042

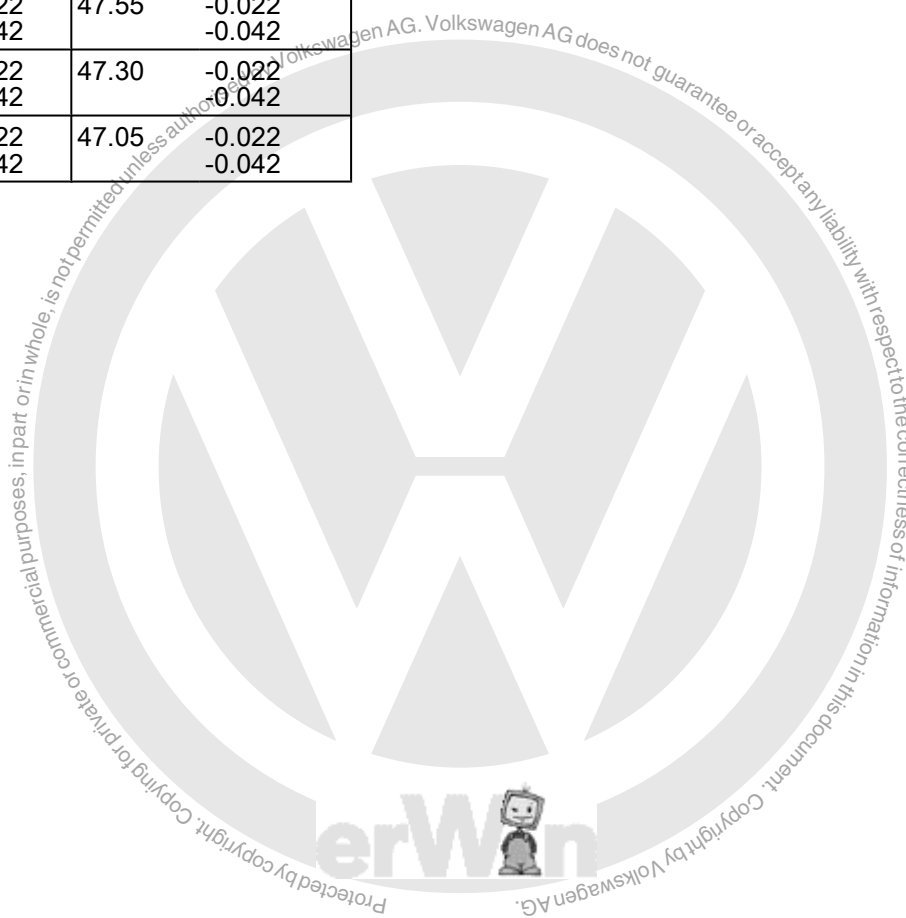



4 Diagnosis and Testing

⇒ "4.1 Crankshaft Axial Clearance, Checking", page 42

⇒ "4.2 Crankshaft Radial Clearance, Checking", page 42

⇒ "4.3 Pistons and Cylinder Bore, Checking", page 43

4.1 Crankshaft Axial Clearance, Checking

Special tools and workshop equipment required

- ◆ Dial Gauge Holder - VW387-
- ◆ Dial Gauge 0-10 mm - VAS6079-

Procedure

- Install the Dial Gauge - VAS6079- with the Dial Gauge Holder - VW387- onto the cylinder block as shown in the illustration.
- Place the dial gauge against the crankshaft counterweight.
- Press the crankshaft against the dial gauge by hand and set the gauge to "0".
- Press the crankshaft off the dial gauge and read the measurement.

Axial clearance:

New: 0.07 to 0.21 mm

Wear limit: 0.30 mm

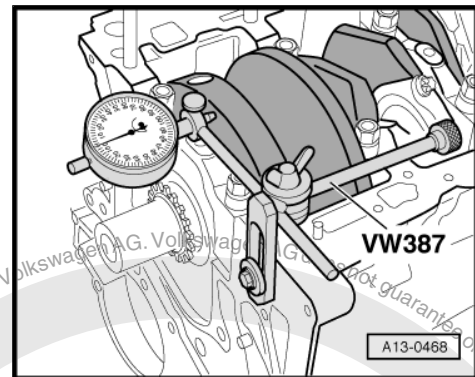

4.2 Crankshaft Radial Clearance, Checking

Special tools and workshop equipment required

- ◆ Plastigage®

Procedure



Note

- ◆ *Marked the used bearing for installation later, but not on the running surface.*
- ◆ *Replace bearing shells that are worn down to the base layer.*
- Remove the bearing cap.
- Clean the bearing cap and bearing journals.
- Place the Plastigage® over the entire width of the bearing journal or into the bearing shell.
- The Plastigage® must rest in the center of the bearing shell.
- Install the bearing cap and tighten the bolts to 40 Nm without rotating the crankshaft.
- Remove the bearing cap.
- Compare the width of the Plastigage® with the calibrated scale.

Radial clearance:

New: 0.023 to 0.043 mm

Wear limit: 0.07 mm



4.3 Pistons and Cylinder Bore, Checking

Piston Ring Gap, Checking

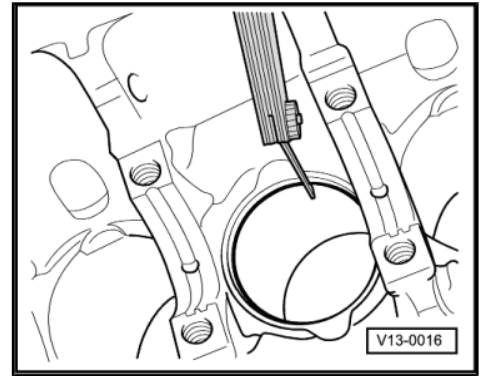

Special tools and workshop equipment required

◆ Feeler Gauge

- Insert the ring at a right angle from above, to the lower end of cylinder approximately 15 mm from the cylinder edge.

Piston Ring		Gap	
		New	Wear limit
Compression rings	mm	0.20 through 0.40	0.8
Oil scraping ring	mm	0.25 through 0.50	0.8

Piston Ring Groove Clearance, Checking

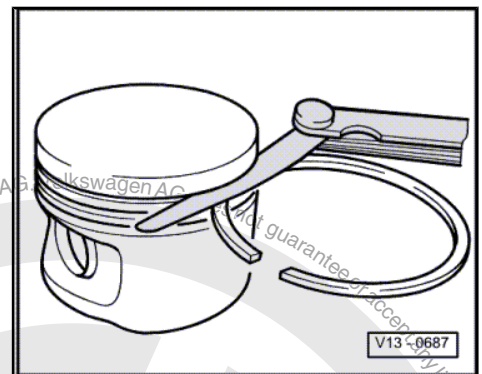

Special tools and workshop equipment required

◆ Feeler Gauge

- Clean the groove in the ring before checking.

Piston Ring		Ring to Groove Clearance	
		New	Wear limit
Compression rings	mm	0.06 through 0.09	0.20
Oil scraping ring	mm	0.03 through 0.06	0.15



Piston, Checking

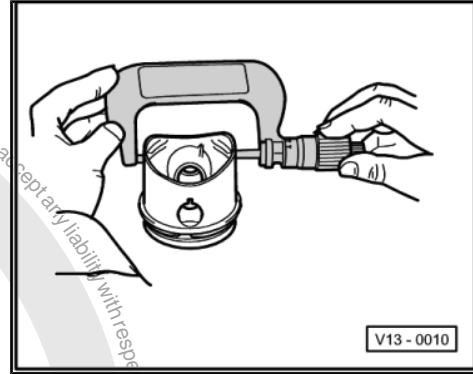

Special tools and workshop equipment required

- ◆ Micrometer 75-100 mm - VAS6071-
- Take the measurement approximately 10 mm from the lower edge of the piston skirt and offset 90° to the piston axis.

Deviation from nominal dimension: Max. 0.04 mm

Cylinder Bore, Checking



Note

The cylinder bore must not be measured if the cylinder block is secured to the engine stand with the Engine Lateral Bracket - T03001- , or else results may be incorrect.

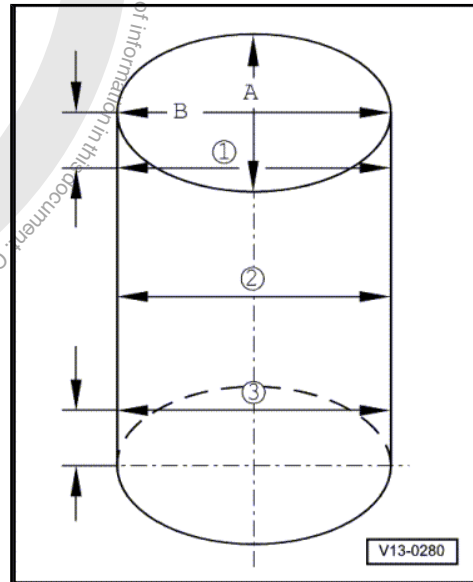

Special tools and workshop equipment required

- ◆ Cylinder Gauge - VAS6078-
- Measure diagonally at 3 positions transversely -A- and longitudinally -B-.

Deviation from nominal size: Max. 0.08 mm.

Piston and Cylinder Reconditioning Dimension

Honing Dimension	Piston Diameter	Cylinder Bore Diameter
Basic dimension mm	82.465 ¹	82.51

- ◆ ¹ The measurement does not include the graphite coating, which is 0.02 mm thick. The graphite coating wears off.



5 Removal and Installation

⇒ [“5.1 Ribbed Belt”, page 45](#)

⇒ [“5.2 Ribbed Belt Tensioner, A/C Compressor”, page 46](#)

⇒ [“5.3 Ribbed Belt Tensioner, Generator, Power Steering Pump and Coolant Pump”, page 47](#)

⇒ [“5.4 Vibration Damper”, page 47](#)

⇒ [“5.5 Sealing Flange, Belt Pulley Side”, page 49](#)

⇒ [“5.6 Seal, Transmission Side”, page 52](#)

⇒ [“5.7 Drive Plate”, page 53](#)

⇒ [“5.8 Flywheel”, page 54](#)

⇒ [“5.9 Sealing Flange, Transmission Side”, page 54](#)

⇒ [“5.10 Piston”, page 57](#)

5.1 Ribbed Belt

Special tools and workshop equipment required

- ◆ Locking Pin - T10060A-

Removing

- Remove the noise insulation. Refer to ⇒ Body Exterior; Rep. Gr. 50 ; Description and Operation .
- Remove the front section of the right wheel housing liner. Refer to ⇒ Body Exterior; Rep. Gr. 66 ; Removal and Installation .

Removing the Air Conditioning (A/C) Compressor Ribbed Belt

- Mark the rotation direction on the ribbed belt.
- Rotate the belt tensioner -1- in the -direction of the arrow- using a 15 mm box end wrench -A- as illustrated, and then lock it into place using the Locking Pin - T10060A- .
- Remove the A/C compressor ribbed belt.

Removing Generator, Power Steering Pump and Coolant Pump Ribbed Belt

- Relieve the tension on the belt tensioner -1- for the A/C compressor ribbed belt (remove the Locking Pin -T10060A-) .
- Mark the running direction of the generator, power steering pump and coolant pump ribbed belt.

- Insert the Locking Pin - T10060A- into the belt tensioner -2-.
- Rotate the belt tensioner -2- in the direction of the -arrow- using a 15 mm box end wrench -A- and then lock it into place using the Locking Pin - T10060A- .
- Remove the generator, power steering pump and coolant pump ribbed belt.

Installing

Install in reverse order of removal. Note the following:

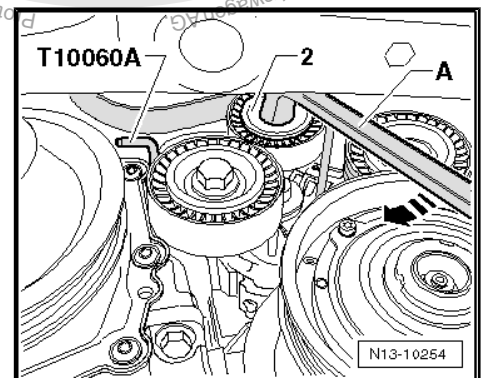
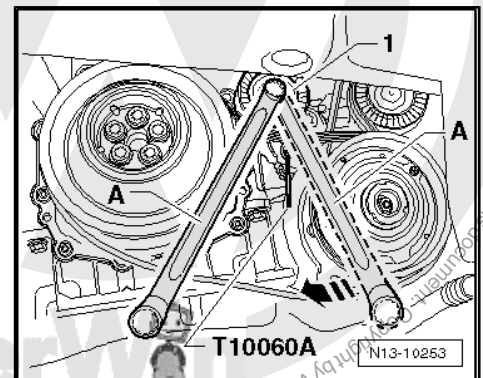



- Place the generator, power steering pump and coolant pump belt around the pulleys, then lastly around the idler pulley -3-.
- Rotate the A/C compressor pulley before tensioning the generator, power steering pump and coolant pump ribbed belt. Make sure the ribbed belt is seated correctly on the pulleys.
- Before installing the A/C compressor ribbed belt, secure the belt tensioner using the Locking Pin - T10060A- .



Note

When installing the ribbed belt, note the rotation direction of the belt and be sure that it is seated correctly on the pulley.

- Start the engine and check the belt running direction.

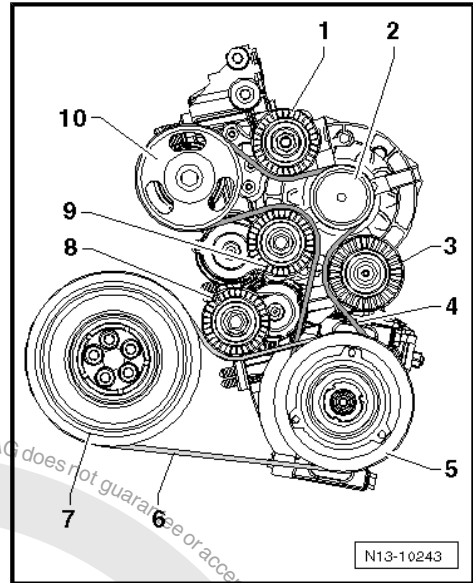

5.2 Ribbed Belt Tensioner, A/C Compressor



Caution

Note the following whenever working inside the engine compartment due to limited space:

- ◆ *Route all lines and wires in their original locations.*
- ◆ *Ensure sufficient clearance to all moving or hot components.*

- Remove the ribbed belt. Refer to => "5.1 Ribbed Belt", page 45 .
- Loosen the bolt -2- for the belt tensioner -1- and remove the tensioner.
- Install in reverse order of removal. Note the following:

Tightening Specification

Component	Nm
Belt tensioner to accessory bracket	35

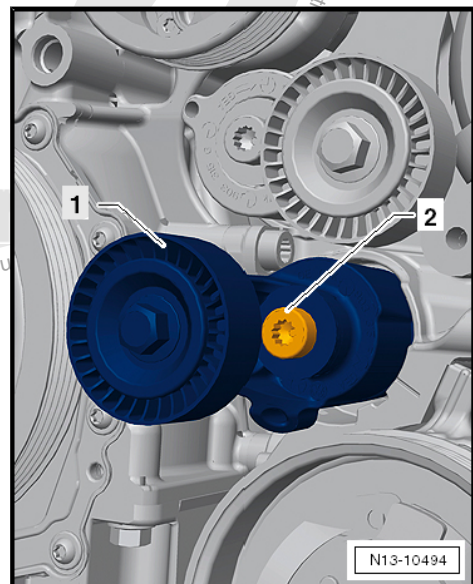



5.3 Ribbed Belt Tensioner, Generator, Power Steering Pump and Coolant Pump

Caution

Note the following whenever working inside the engine compartment due to limited space:

- ◆ *Route all lines and wires in their original locations.*
- ◆ *Ensure sufficient clearance to all moving or hot components.*

- Remove the ribbed belt. Refer to ⇒ ["5.1 Ribbed Belt", page 45](#) .
- Loosen the bolt -2- for the belt tensioner -1- and remove the tensioner.
- Install in reverse order of removal. Note the following:

Tightening Specification

Component	Nm
Belt tensioner to accessory bracket	35

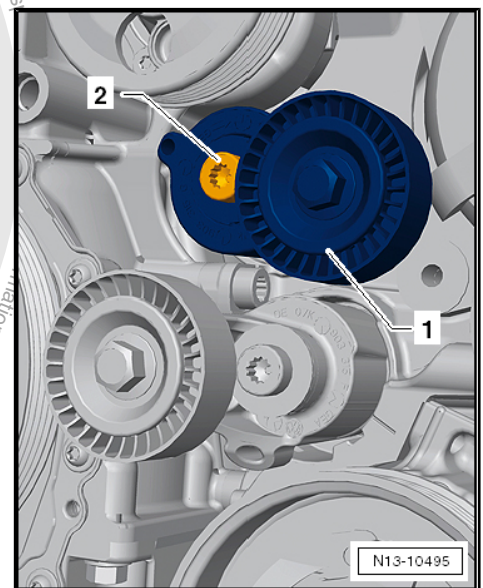

5.4 Vibration Damper

Special tools and workshop equipment required

- ◆ Torque Wrench (5-50 Nm) - VAG1331-
- ◆ Crankshaft Adapter - T03003-
- ◆ Locking Pin - T40069-

Caution

Note the following whenever working inside the engine compartment due to limited space:

- ◆ *Route all lines and wires in their original locations.*
- ◆ *Ensure sufficient clearance to all moving or hot components.*

Procedure

- Remove the noise insulation. Refer to ⇒ Body Exterior; Rep. Gr. 66 ; Description and Operation .
- Remove the right front wheel housing liner. Refer to ⇒ Body Exterior; Rep. Gr. 66 ; Removal and Installation .



- Install the Crankshaft Adapter - T03003- onto the bolts for the vibration damper.

The Crankshaft Adapter - T03003- can only be installed correctly in one position.

- Rotate the crankshaft in engine rotation in direction of -arrow- far enough until arrow -A- on the Crankshaft Adapter - T03003- points downward vertically, relative to engine axis.

This position corresponds approximately to the Top Dead Center (TDC) position of the crankshaft at cylinder 5.

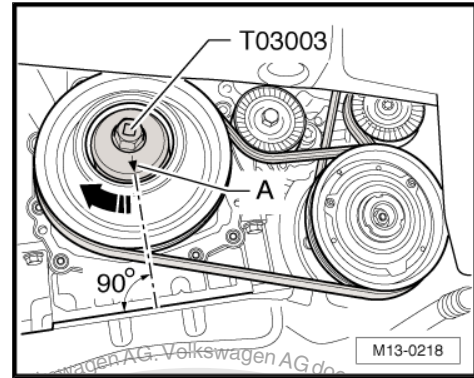

i Note

With the engine removed, The TDC mark can also be seen on the vibration damper and sealing flange. The notches -A and B- must align.

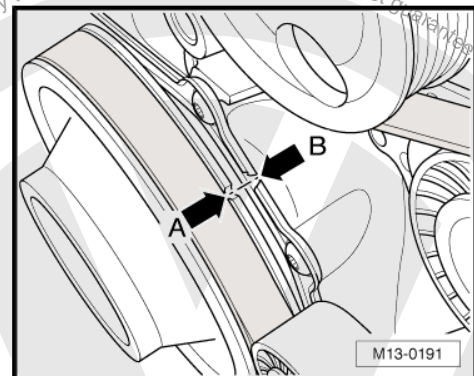

- Remove the locking bolt -1- from the back of the cylinder block.
 - Look through the threaded hole. Make sure the bore -2- in the crankshaft is lined up with the threaded hole.
- Use a mirror for this, if necessary
- Rotate the crankshaft slightly, if necessary.
 - When the bore and hole line up, install the Locking Pin - T40069- all the way into the threaded hole and tighten it to 10 Nm. Make sure the crankshaft cannot be rotated.

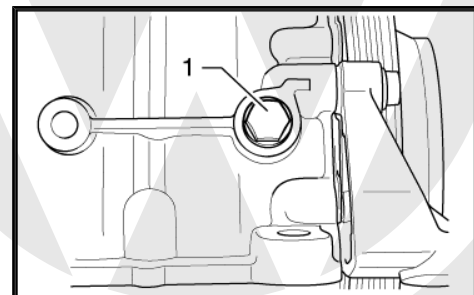

- Remove the Air Conditioning (A/C) compressor ribbed belt. Refer to ⇒ ["5.1 Ribbed Belt", page 45](#) .
- Loosen the bolts for the vibration damper and remove the vibration damper.

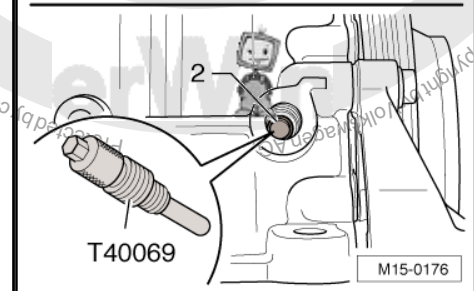

- Replace the bolts
- Use strength category 10.9 bolts only
- 50 Nm + an additional 90° (1/4) I turn

After Disassembly and Assembly Work



- Remove the Locking Pin - T40069- and install the locking bolt -1-.

The rest of the installation follows the reverse of the removal procedure.

Tightening Specifications

Component	Nm
Locking bolt to rear of cylinder block	30

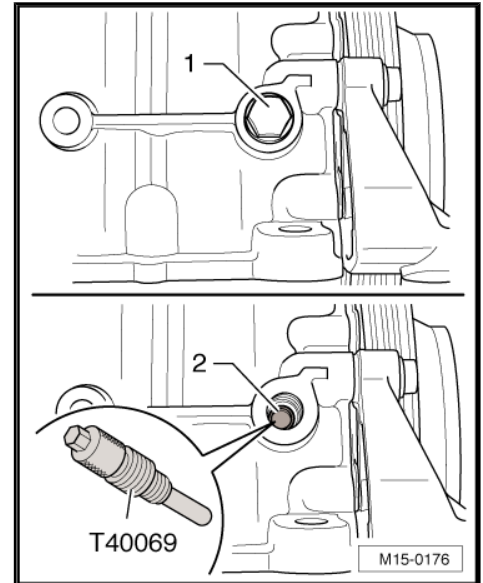

5.5 Sealing Flange, Belt Pulley Side

Special tools and workshop equipment required

- ◆ Trim Removal Wedge - 3409-
- ◆ Oil Seal Guide Sleeve - T03004-
- ◆ Hand Drill with Plastic Brush Attachment
- ◆ Protective Eyewear
- ◆ Silicone Sealant - D174003A2-

Removing

- Remove the Air Conditioning (A/C) compressor ribbed belt. Refer to ⇒ ["5.1 Ribbed Belt", page 45](#) .
- Lock the crankshaft. Refer to ⇒ ["2.8 Crankshaft, Locking", page 36](#) .
- Remove the vibration damper.
- Remove the belt tensioner -1-.
- Remove the bolts -2-.

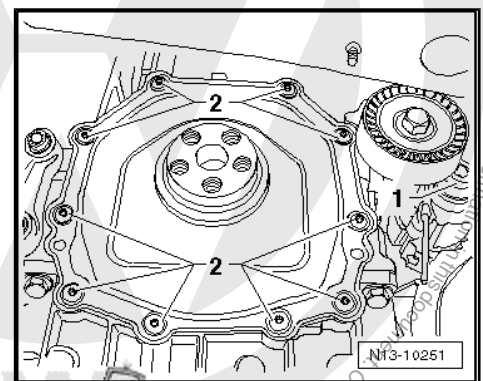

Protected by copyright. Copying for private or commercial purposes, in part or in whole, is not permitted unless authorised by Volkswagen AG. Volkswagen AG does not guarantee or accept any liability with respect to the correctness of information.



- Beginning at the alignment bushings -arrows-, pry off the sealing flange -1- using a suitable screwdriver -A-.
 - Use the Trim Removal Wedge - 3409- to support the screwdriver in order to prevent damage to the sealing surface on the cylinder block.
- The sealing flange is damaged while removing.
- Pry off the sealing flange completely.

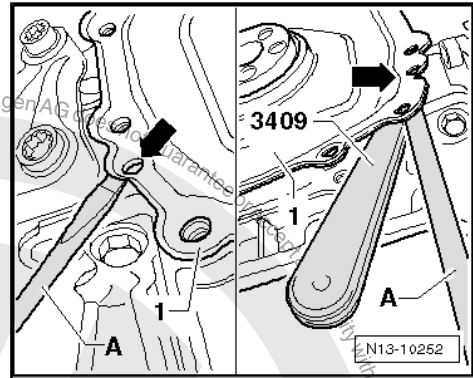

Note

After removing the sealing flange, clean the Trim Removal Wedge - 3409- which is intended for the removal of interior equipment parts.

Installing



WARNING

To prevent injuries from shavings, wear protective goggles and protective clothing.

- Remove the remainder of the sealant from the cylinder block, using a rotating plastic brush, for example.



Caution

Make sure that no sealant residue enters the engine.

- Clean the sealing surfaces on the cylinder block and crankshaft journal. They must be free of oil and grease.



Note

- ◆ Do not additionally oil or grease the sealing lip of the sealing flange!
 - ◆ The following steps must be followed so that the sealing lip of the sealing flange does not roll itself up when installing.
- Widen the sealing lip of the new sealing flange as shown using the Oil Seal Guide Sleeve - T03004- .
- The surface -A- is the outer side.

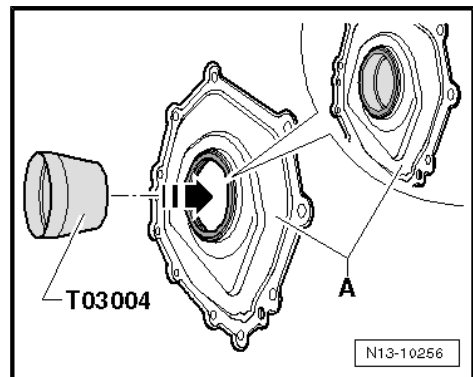



- After a short time, remove the Oil Seal Guide Sleeve - T03004- and slide it rotated 180° into the seal.

the Oil Seal Guide Sleeve - T03004- must stand out approximately 3 mm on the inner side -B-.
 The surface -A- is the outer side.
 The surface -B- is the inner side (sealing surface).

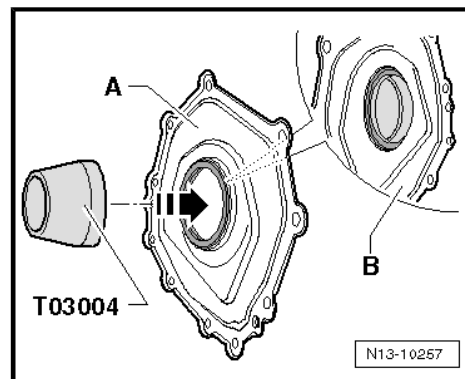

- Cut the sealant tube nozzle at the front mark (nozzle diameter: approximately 2 mm).

i Note

The sealing flange must be installed within 5 minutes after application of the sealant.

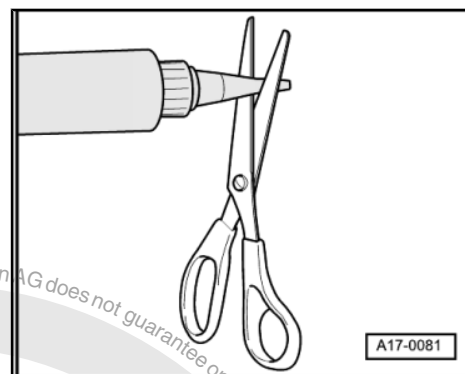

- Apply the sealant bead -A- as shown into the groove in the sealing flange.

- ◆ Width of sealant bead: 2.5 to 3.0 mm
- ◆ Height of sealant bead above the sealing surface: approximately 1.0 mm

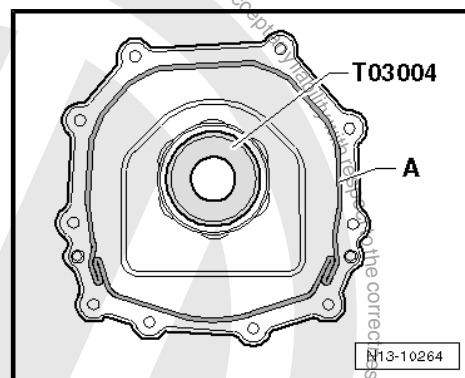

- Insert the sealing flange using the Oil Seal Guide Sleeve - T03004- on the crankshaft journal and press the sealing flange uniformly onto the cylinder block.

- Tighten the bolts -A- uniformly in a diagonal sequence.

The rest of the installation follows the reverse of the removal procedures. Note the following:

- ◆ Remove the Locking Pin - T40069- from the cylinder block and install the plug.

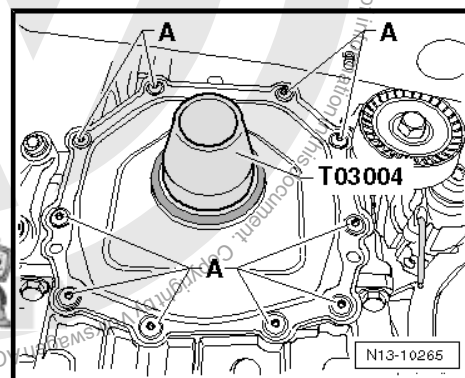

Tightening Specifications

Component	Nm
Vibration damper to crankshaft	50 Nm + an additional 90° (1/4) turn (replace the bolts)
Belt tensioner to accessory bracket	35
Sealing flange to cylinder block	10
Locking bolt to rear of cylinder block	30



5.6 Seal, Transmission Side

Special tools and workshop equipment required

- ◆ Assembly Tool - T10122-
- ◆ Pulling Hook - T20143-

Removing

- Remove the transmission. Refer to one of the following:
 - ⇒ Manual Transmission; Rep. Gr. 34 ; Removal and Installation .
 - ⇒ Automatic Transmission; Rep. Gr. 37 ; Removal and Installation .
- Lock the crankshaft. Refer to [⇒ "2.8 Crankshaft, Locking", page 36](#) .
- Remove the flywheel or drive plate and remove the sensor wheel for the Engine Speed Sensor - G28- from the crankshaft.
- Pull out the seal using the Pulling Hook - T20143/2- .

Be careful not to damage the sealing surface on the crankshaft.

Installing



Note

Do not lubricate or grease the sealing lip on the seal.

- Clean the sealing surfaces. They must be free of oil and grease.
- Before installing, remove any remaining oil from the crankshaft journal with a clean cloth.
- Insert the Assembly Device - T10122/1- onto the Pull Sleeve - T10122/2- and slide the seal -A- onto the pull sleeve.
- Remove the Assembly Device - T10122/1- .

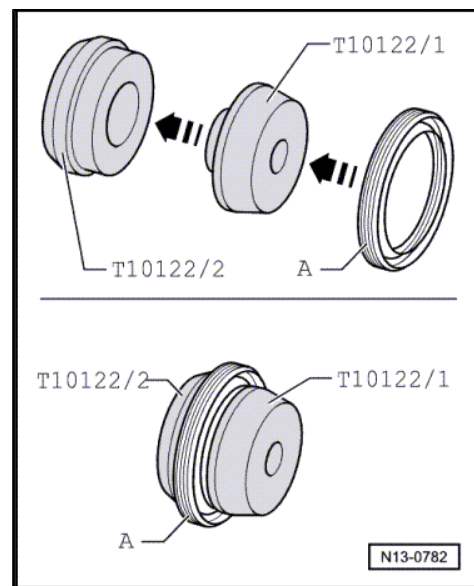
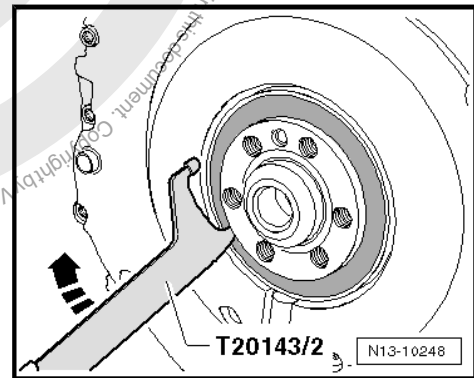



- Install the Pull Sleeve - T10122/2- with the seal -A- onto the crankshaft.
- Press in the seal all around evenly and flush using the Pressure Sleeve - T10122/3- .

The rest of the installation follows the reverse of the removal procedure. Note the following:

- ◆ Remove the Locking Pin - T40069- from the cylinder block and install the plug.

Tightening Specifications

Component	Nm
Flywheel/drive plate to crankshaft ◆ Replace bolts	60 + an additional 90° (1/4) turn
Locking bolt to rear of cylinder block	30

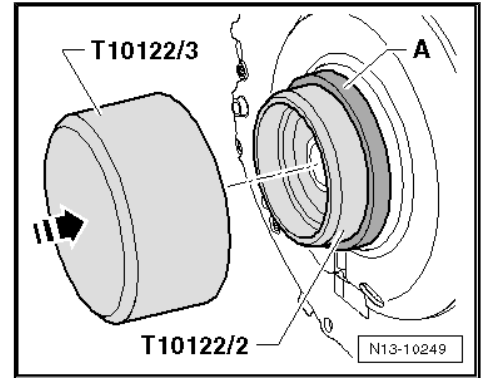

5.7 Drive Plate

Special tools and workshop equipment required

- ◆ Depth Gauge

Removing

- Remove the transmission. Refer to ⇒ Automatic Transmission; Rep. Gr. 37 ; Removal and Installation .
- Lock the crankshaft. Refer to ⇒ "2.8 Crankshaft, Locking", page 36 and remove the drive plate.

Installing

- Install the drive plate only using the washer with openings -1- and without a shim -2-.
- Insert the new bolts -3- and tighten them to 30 Nm.

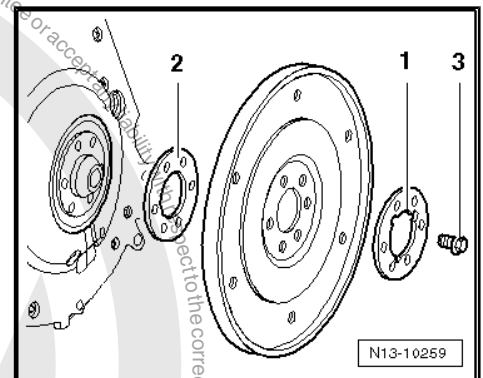

- Check the dimension -a- at three points and calculate the average value.

Specified value: 18.8 to 20.4 mm

Note

Measure through the drive plate hole to the surface of sealing flange.

If the specification is not obtained:

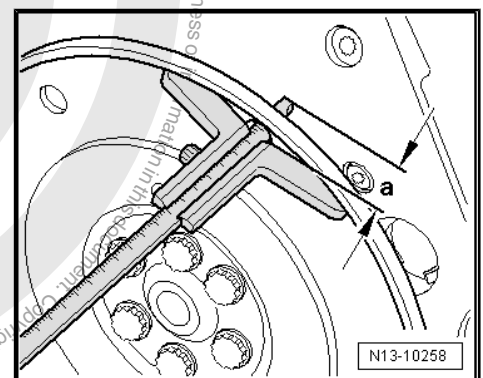



- Remove the drive plate and install the shim -2-. Tighten the bolts -3- to 30 Nm again and repeat the measurement.

If the specified value is OK:

- Tighten the bolts to 60 Nm + an additional 90° (1/4) turn (the additional 90° turn may occur in several stages).

The rest of the installation follows the reverse of the removal procedure. Note the following:

- ◆ Remove the Locking Pin - T40069- from the cylinder block and install the plug (30 Nm).

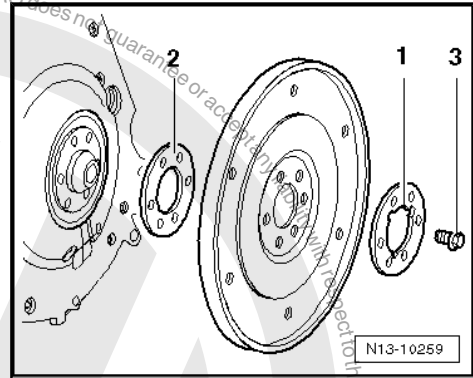

5.8 Flywheel

Special tools and workshop equipment required

- ◆ Torque Wrench (5-50 Nm) - VAG1331-
- ◆ Crankshaft Adapter - T03003-
- ◆ Locking Pin - T40069-

Removing

- Remove the transmission. Refer to ⇒ Manual Transmission; Rep. Gr. 34 ; Removal and Installation .
- Lock the crankshaft. Refer to ⇒ ["2.8 Crankshaft, Locking"](#), page 36
- Mark the flywheel to the engine.
- Remove the bolts and the flywheel.

Installing

Install in reverse order of removal. Note the following:

Tightening specification. Refer to ⇒ ["2.6 Flywheel Overview"](#), page 34 .

- Use new bolts.

5.9 Sealing Flange, Transmission Side

Special tools and workshop equipment required

- ◆ Torque Wrench (5-50 Nm) - VAG1331-
- ◆ Torque Wrench (40-200 Nm) - VAG1332-
- ◆ Hand Drill with Plastic Brush Attachment
- ◆ Protective Eyewear
- ◆ Silicone Sealant - D174003A2-



Caution

Note the following whenever working inside the engine compartment due to limited space:

- ◆ *Route all lines and wires in their original locations.*
- ◆ *Ensure sufficient clearance to all moving or hot components.*



Removing

- The engine is removed, and the transmission is separated from the engine.
- Remove the timing chain cover. Refer to ⇒ ["4.4 Timing Chain Cover", page 86](#) .
- Remove the flywheel or drive plate and then remove the sensor wheel for the Engine Speed Sensor - G28- from the crankshaft.
- Remove the cylinder head. Refer to ⇒ ["4.2 Cylinder Head", page 80](#) .
- Disengage the wiring harness -arrow- and remove the engine speed sensor -1- and vacuum pump -2-.
- Remove the bolts -3-.

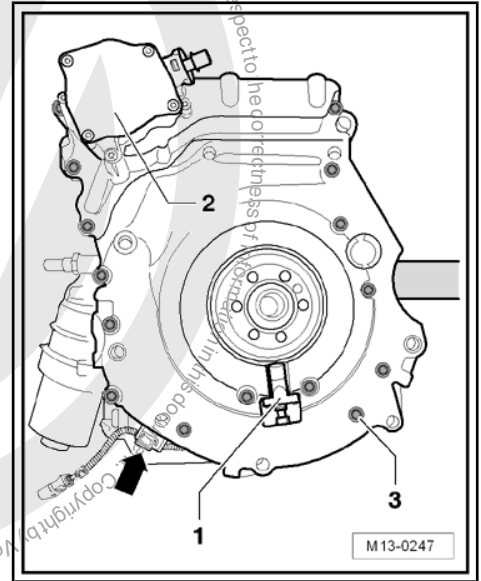



- Remove the sealing flange -1- from the cylinder block -2- and from the lower oil pan -3- at the upper and lower marked locations using a screwdriver -A- .

Start near the alignment sleeves -arrows-.

i Note

Be careful not to damage the sealing surfaces.

- Remove the seal from the removed sealing flange.

Installing

! WARNING
To prevent injuries from shavings, wear protective goggles and protective clothing.

- Remove the sealant residue from the cylinder block, upper oil pan and sealing flange using a rotating plastic brush.

! Caution
Make sure that no sealant residue gets into the engine.

- Clean the sealing surfaces on the cylinder block, the upper oil pan and on the sealing flange. There must not be any oil or grease on them.

- Replace the seals -1 and 2-.

- Cut the sealant tube nozzle at the front mark (nozzle diameter: approximately 1 mm).

i Note

The sealing flange must be installed within 5 minutes after application of the sealant.

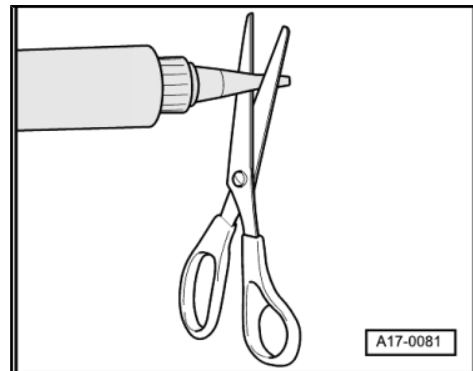
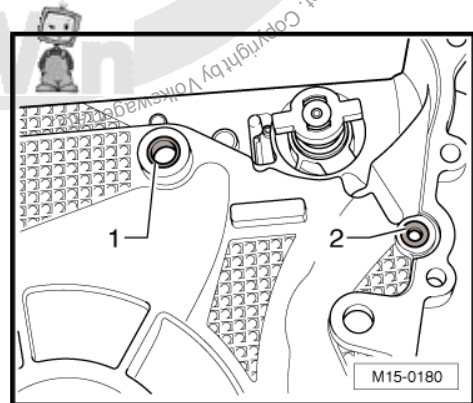
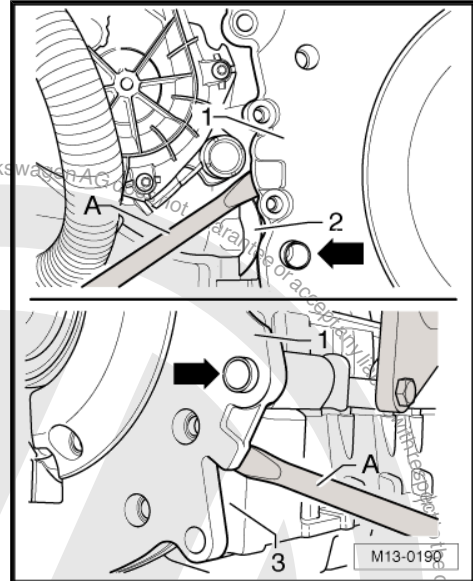



- Apply the sealant bead -A- to the sealing flange as shown.
- ◆ The sealant bead must be 1.5 to 2.0 mm thick.
- ◆ Pay special attention to the course of the sealant bead in the area of the -arrow-.
- Install the sealing flange so that the alignment sleeve fit into the holes in the cylinder block.
- Install the bolts hand tight.

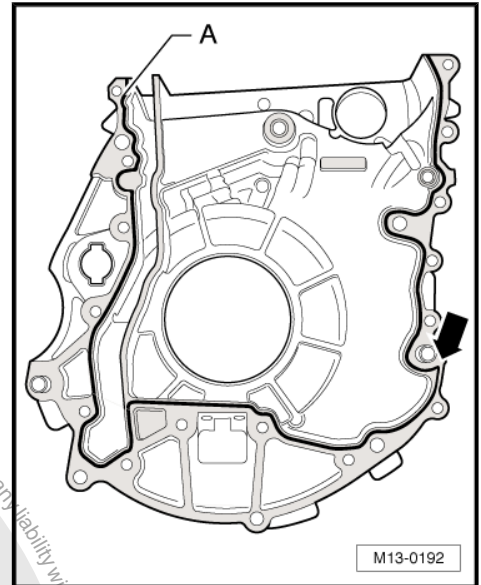

- Install the bolts -3- in the cylinder block and in the upper oil pan and tighten them to 10 Nm.
- Tighten the bolts in the cylinder block and upper oil pan to 25 Nm.
- Wipe off any sealant that leaks out.
- Install the alignment sleeves all the way.
- Install a new seal. Refer to ["5.6 Seal, Transmission Side", page 52](#).

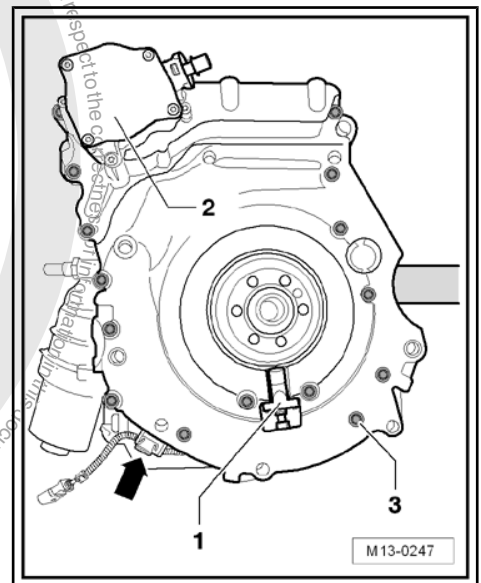

The rest of the installation follows the reverse of the removal procedure. Note the following:

- ◆ Install the brake booster vacuum pump. Refer to ["4.3 Vacuum Pump", page 84](#).
- ◆ Install the cylinder head. Refer to ["4.2 Cylinder Head", page 80](#).
- ◆ Install the drive plate. Refer to ["5.7 Drive Plate", page 53](#).
- ◆ Or, install the flywheel. Refer to ["5.8 Flywheel", page 54](#).
- ◆ Remove the Locking Pin - T40069- from the cylinder block and install the plug.
- ◆ Fill the coolant. Refer to ["1.1 Coolant, Draining and Filling", page 121](#).

Tightening Specifications

Component	Nm
Flywheel/drive plate to crankshaft ◆ Replace bolts	60 + an additional 90° (1/4) turn
Locking bolt to rear of cylinder block	30

5.10 Piston

Special tools and workshop equipment required

- ◆ Drip Tray - VAG1306- or Drip Tray for VAS6100 - VAS6208-
- ◆ Torque Wrench (5-50 Nm) - VAG1331-
- ◆ Torque Wrench (40-200 Nm) - VAG1332-



- ◆ Spring Type Clip Pliers - VAS5024A-
- ◆ Polydrive Bit and Drive Socket - T10070-
- ◆ Ignition Coil Puller - T40039-
- ◆ Silicone Sealant - D174003A2-

Removing

- Remove the engine. Refer to
⇒ ["3.2 Engine, Removing", page 9](#) .
- Separate the engine and transmission. Refer to
⇒ ["3.3 Engine and Transmission, Separating", page 14](#)
- Secure the engine to the engine and transmission holder. Refer to
⇒ ["3.4 Engine, Securing to the Engine and Transmission Holder VAS6095", page 18](#) .
- Remove the cylinder head. Refer to
⇒ ["4.2 Cylinder Head", page 80](#) .
- Remove the upper oil pan. Refer to
⇒ ["4.2 Upper Oil Pan", page 109](#) .
- Mark the installed position and cylinder allocation on the piston to be removed.
- Remove the connecting rod bearing cap and pull the piston and connecting rod upward.



Note

Heat the piston to approximately 60 °C (140 °F) if it is difficult to move the piston pin.

- Remove the circlip from the eye of the piston pin.
- Remove the piston pin using a Pilot Drift - VW222A- .

Installing

Installation is performed in the reverse order of removal.

- Tightening specification. Refer to
⇒ ["2.9 Pistons and Connecting Rod Overview", page 38](#) .



Note

- ◆ *Replace the bolts which have been tightened to a torque angle.*
- ◆ *The arrow on the piston face points toward the belt pulley side.*
- ◆ *Offset the piston ring gap by 120° .*
- Coat the contact surfaces on the bearing shells with oil.
- Install the piston with a piston ring compressor. Pay attention to the installed position.
- Install the connecting rod bearing cap. Pay attention to the installed position.
- Install the upper oil pan. Refer to
⇒ ["4.2 Upper Oil Pan", page 109](#) .
- Install the cylinder head. Refer to
⇒ ["4.2 Cylinder Head", page 80](#) .



- Install the transmission to the engine. Refer to
⇒ [“3.3 Engine and Transmission, Separating”, page 14](#) .
- Install the engine. Refer to
⇒ [“3.5 Engine, Installing”, page 20](#) .





6 Special Tools

Special tools and workshop equipment required

- ◆ Micrometer 75-100 mm - VAS6071-
- ◆ Cylinder Gauge - VAS6078-
- ◆ Crankshaft Adapter - T03003-
- ◆ Locking Pin - T40069-
- ◆ Dial Gauge Holder - VW387-

- ◆ Dial Gauge 0-10 mm - VAS6079-

- ◆ Locking Pin - T10060A-

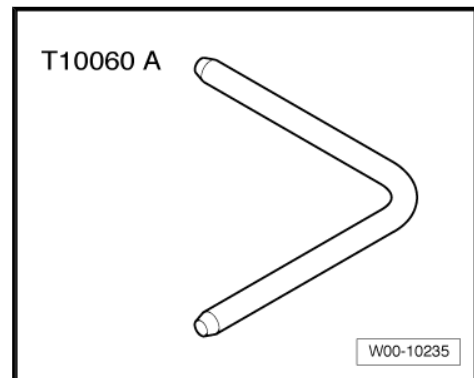
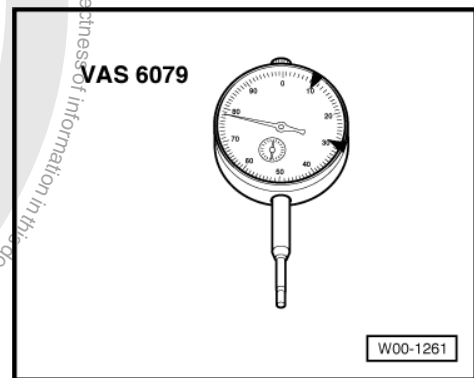
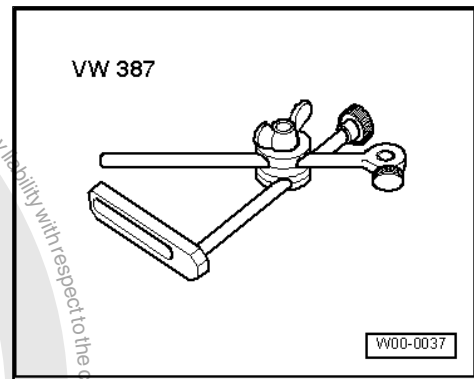



- ◆ Trim Removal Wedge - 3409-

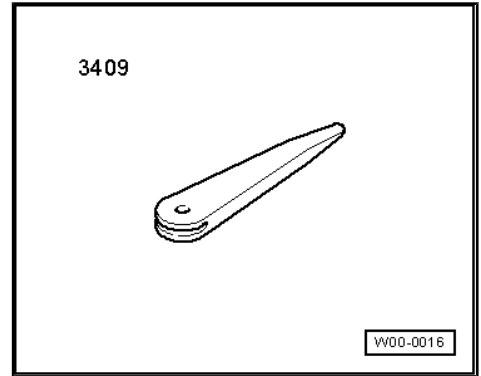

- ◆ Oil Seal Guide Sleeve - T03004-

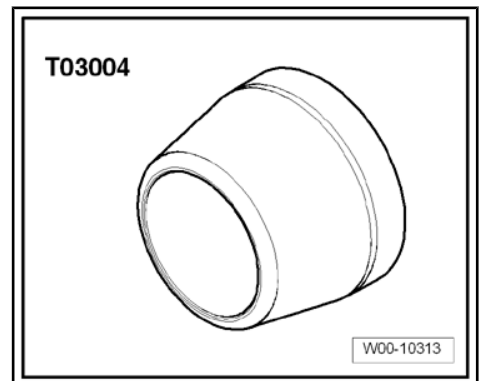

- ◆ Assembly Tool - T10122-

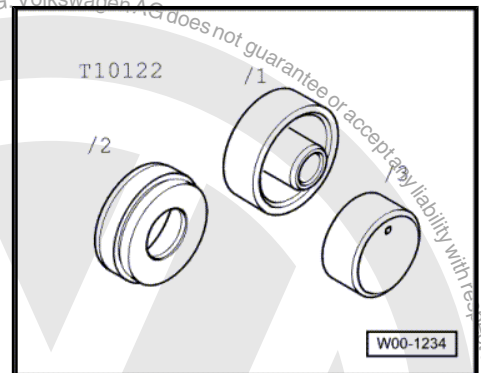



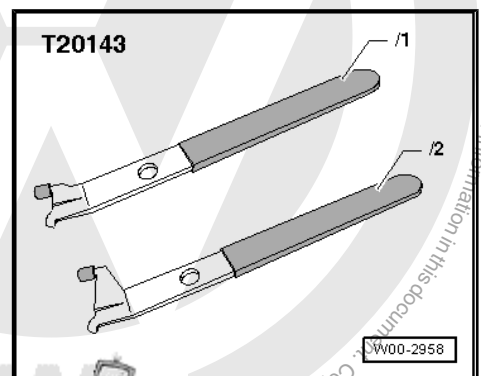

- ◆ Pulling Hook - T20143-



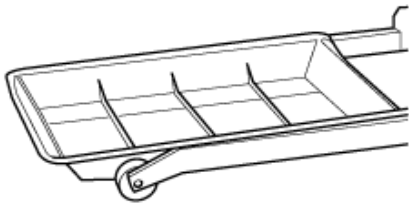

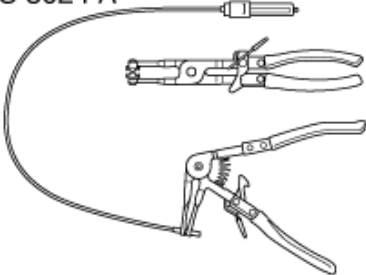
- ◆ Drip Tray - VAG1306- or Drip Tray for VAS6100 - VAS6208-
- ◆ Torque Wrench (5-50 Nm) - VAG1331-
- ◆ Torque Wrench (40-200 Nm) - VAG1332-
- ◆ Spring Type Clip Pliers - VAS5024A-
- ◆ Polydrive Bit and Drive Socket - T10070-
- ◆ Ignition Coil Puller - T40039-

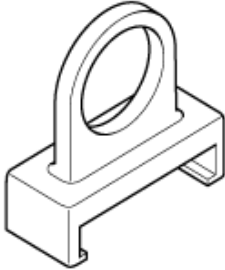
<p>V.A.G 1306</p> 	<p>V.A.G 1331</p> 
<p>V.A.G 1332</p> 	<p>VAS 5024 A</p> 
<p>T10070</p> 	<p>T40039</p>  <p>W15-10004</p>

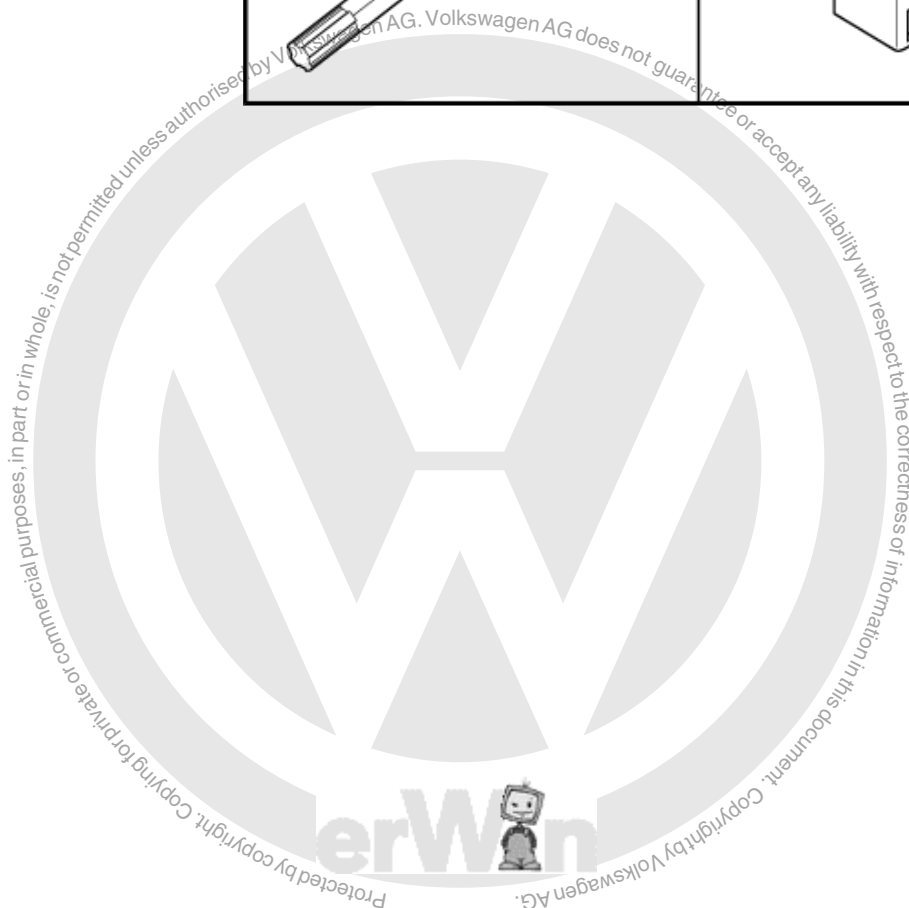



15 – Cylinder Head, Valvetrain

1 Description and Operation

⇒ [“1.1 Cylinder Head Overview”, page 63](#)

⇒ [“1.2 Timing Chain Routing Overview”, page 65](#)

⇒ [“1.3 Camshaft Timing Chain Overview”, page 66](#)

⇒ [“1.4 Oil Pump Timing Chain Overview”, page 67](#)

⇒ [“1.5 Valvetrain Overview”, page 68](#)

1.1 Cylinder Head Overview

1 - Bolt

- 10 Nm

2 - Cylinder Head Cover

- With the pressure regulator valve for the crankshaft housing ventilation.
- Tightening sequence. Refer to ⇒ [Fig. “Cylinder Head Cover Bolt Tightening Sequence”](#), page 64 .
- Removing and installing. Refer to ⇒ [“4.1 Cylinder Head Cover”, page 79](#) .

3 - Cylinder Head Cover Gasket

- Replace if damaged or leaking.

4 - Crankcase Ventilation Hose

- To the intake manifold.

5 - Cap

6 - Gasket

- Replace if damaged or leaking.

7 - Bolt

- 10 Nm

8 - Wire Bracket

9 - Seal

- Removing and installing. Refer to ⇒ [“4.5 Timing Chain Cover Seal”, page 88](#) .

10 - Wire Bracket

11 - Timing Chain Cover

- Removing and installing. Refer to ⇒ [“4.4 Timing Chain Cover”, page 86](#) .

12 - Bolt

- 2 Nm

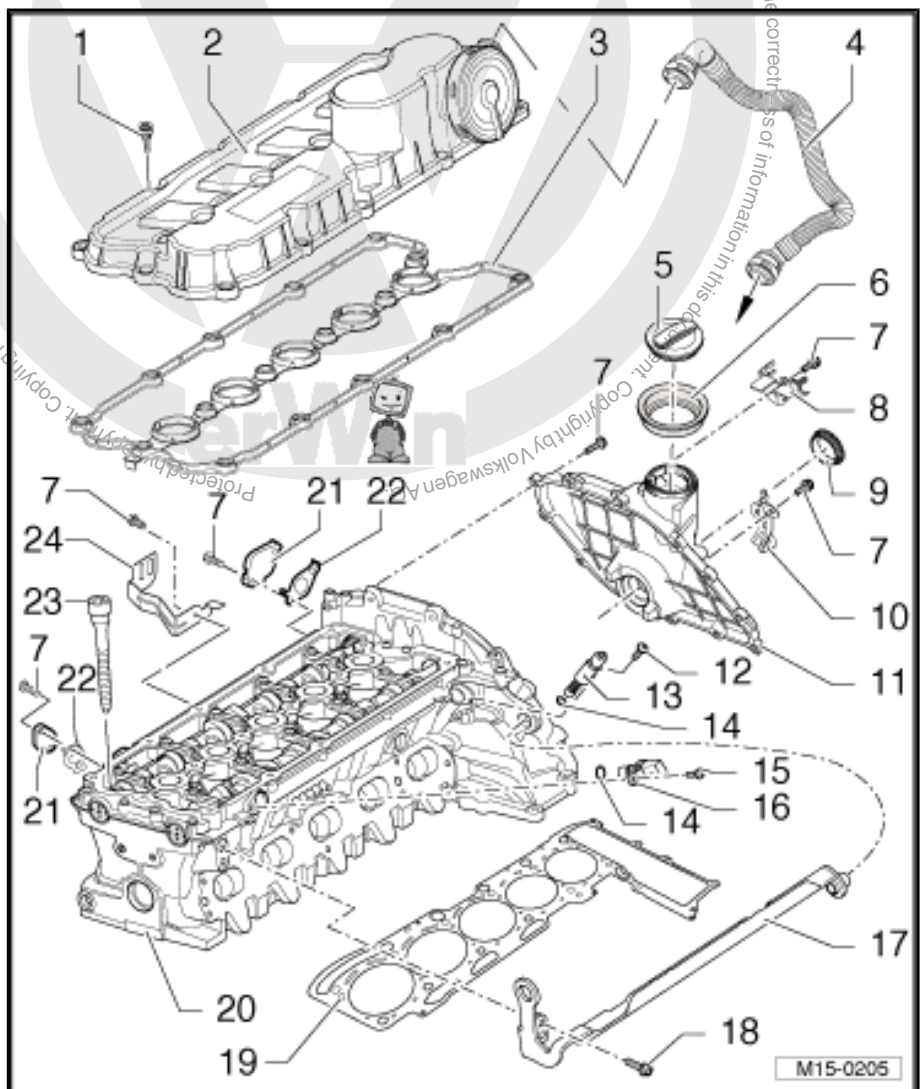



13 - Camshaft Adjustment Valve 1 - N205-

- Check using the vehicle diagnostic tester.

14 - O-Ring

- Replace if damaged.

15 - Bolt

- 10 Nm

16 - Camshaft Position Sensor - G40-

17 - Transport Strap

18 - Bolt

- 25 Nm

19 - Cylinder Head Gasket

- Always replace.
- After replacing, replace the entire amount of coolant.

20 - Cylinder Head

- Removing and installing. Refer to ⇒ ["4.2 Cylinder Head", page 80](#) .
- Checking the cylinder head for warpage. Refer to ⇒ [Fig. "Checking the Cylinder Head for Distortion", page 65](#) .
- It is not permitted to rework the sealing surface.
- With the coolant pipe connection pressed in.
 - If necessary, remove any coolant deposits with a brass wire brush or with a fine sandpaper (minimum 100 grit).
 - If the pipe connection is worn, replace it using Liquid Locking Fluid - D000600A2 .

21 - Cap

- Only on engines with Secondary Air Injection (AIR).
- AIR system overview. Refer to ⇒ ["1.1 Secondary Air Injection System Overview", page 177](#) .

22 - Gasket

- Always replace.

23 - Bolt

- 40 Nm + an additional 180° (1/2) additional turn.
- Always replace.
- Follow the loosening and tightening sequence. Refer to ⇒ ["4.2 Cylinder Head", page 80](#) .

24 - Wire Bracket

- For the Heated Oxygen Sensor - G39- .

Cylinder Head Cover Bolt Tightening Sequence

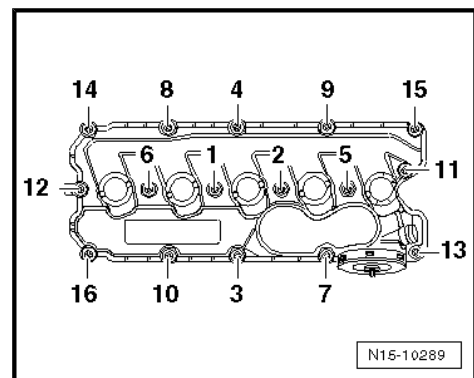



Checking the Cylinder Head for Distortion

– Check the cylinder head at multiple points for distortion, using a straight edge and feeler gauges.

◆ Maximum permissible distortion: 0.05 mm

If this value is exceeded, the cylinder head must be replaced. It is not permissible to rework the sealing surface.

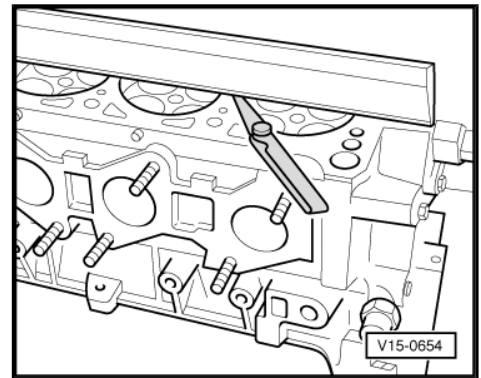

1.2 Timing Chain Routing Overview

1 - Exhaust Camshaft Sprocket

2 - Camshaft Timing Chain, Chain Tensioner

- At the top, with a sliding insert.

3 - Camshaft Timing Chain

4 - Camshaft Timing Chain Tensioning Rail

- For the chain tensioner for the timing chain.
- Secured to the cylinder block.

5 - Oil Pump Timing Chain, Chain Tensioner

- With the tensioning rail.

6 - Crankshaft Sprocket

- Component of the crankshaft.

7 - Oil Pump Timing Chain Guide Rail

- Secured to the upper oil pan.

8 - Oil Pump Sprocket

- Removing and installing. Refer to one of the following:

Engine codes BGP and BGQ. Refer to ["4.3 Oil Pump", page 112](#).

Engine codes CBTA and CBUA. Refer to ["4.4 Oil Pump", page 115](#).

9 - Oil Pump Timing Chain Guide Rail

10 - Oil Pump Timing Chain

- From MY 2008 the roller chain has been changed to a toothed chain.

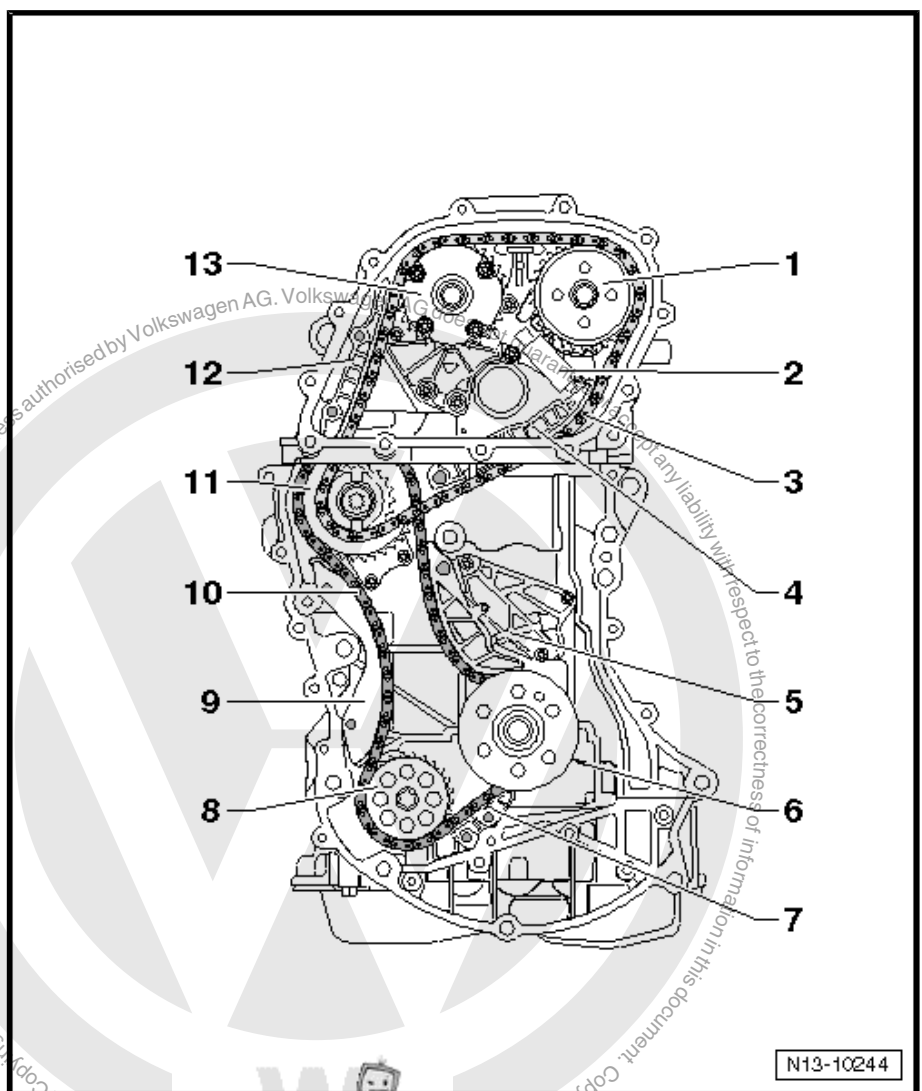



11 - Camshaft and Oil Pump Timing Chains Double Sprocket

12 - Camshaft Timing Chain Guide Rail

13 - Intake Camshaft Adjuster

- With a chain sprocket.

1.3 Camshaft Timing Chain Overview

1 - Intake Camshaft Adjuster

- With the chain sprocket.
- Do not disassemble.

2 - Exhaust Camshaft Sprocket

- Not pressed on the camshaft.
- When removing, pry off lightly, if necessary.

3 - Cylinder Head

4 - Tensioning Rail

- For the chain tensioner for the camshaft timing chain.
- Secured to the cylinder block.
- Oil before installing on the pin.

5 - Double Sprocket

- Securing. Refer to ["1.4 Oil Pump Timing Chain Overview", page 67](#).

6 - Timing Chain

- Removing:
 - Follow the procedure for the "valve timing, adjusting". Refer to ["3.3 Valve Timing, Adjusting", page 75](#).
 - Remove the vacuum pump. Refer to ["4.3 Vacuum Pump", page 84](#).
 - Mark the direction of travel.
- Note when installing:
 - Install in the original direction of rotation.
 - The chain must lie correctly in the tensioning and guide rails.
 - Adjust the valve timing. Refer to ["3.3 Valve Timing, Adjusting", page 75](#).

7 - Strainer

- Always replace.

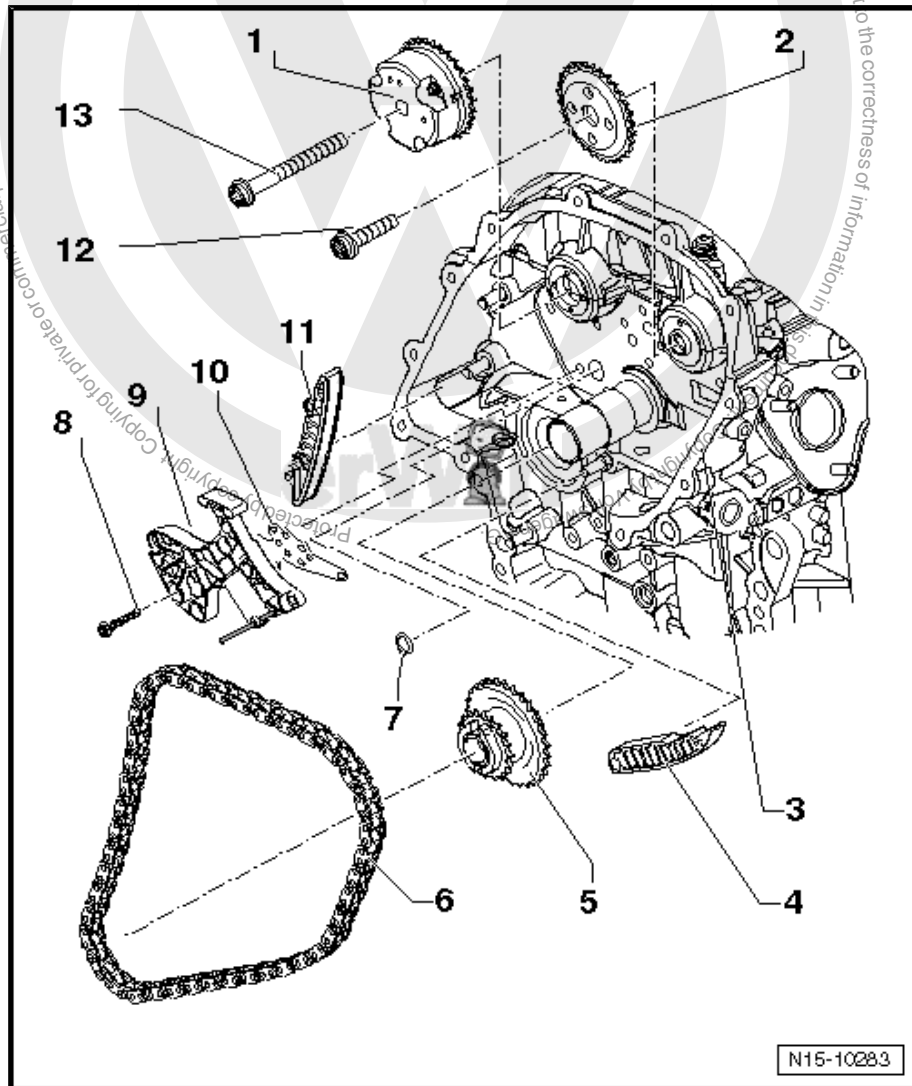



8 - Bolt

- 10 Nm

9 - Chain Tensioner

- Secure using a Locking Pin - T03006- .

10 - Gasket

- Always replace.

11 - Guide Rail

- Oil before installing on the pin.

12 - Bolt

- 60 Nm + an additional 90° (1/4) additional turn.
- Always replace.

13 - Bolt

- 60 Nm + an additional 90° (1/4) additional turn.
- Always replace.

1.4 Oil Pump Timing Chain Overview

1 - Cylinder Block

2 - Guide Rail

- Secured to the upper oil pan.
- Oil before installing on the pin.

3 - Chain Tensioner

- Secure using a Locking Pin - T10115- .

4 - Bolt

- 10 Nm

5 - Oil Pump Sprocket

- Removing and installing. Refer to one of the following:

Engine codes BGP and BGQ. Refer to ["4.3 Oil Pump", page 112](#) .

Engine codes CBTA and CBUA. Refer to ["4.4 Oil Pump", page 115](#) .

6 - Oil Pump Timing Chain

- From MY 2008 the roller chain has been changed to a toothed chain.
- Removing:
 - Remove the engine.
 - Remove sealing flange, transmission side.

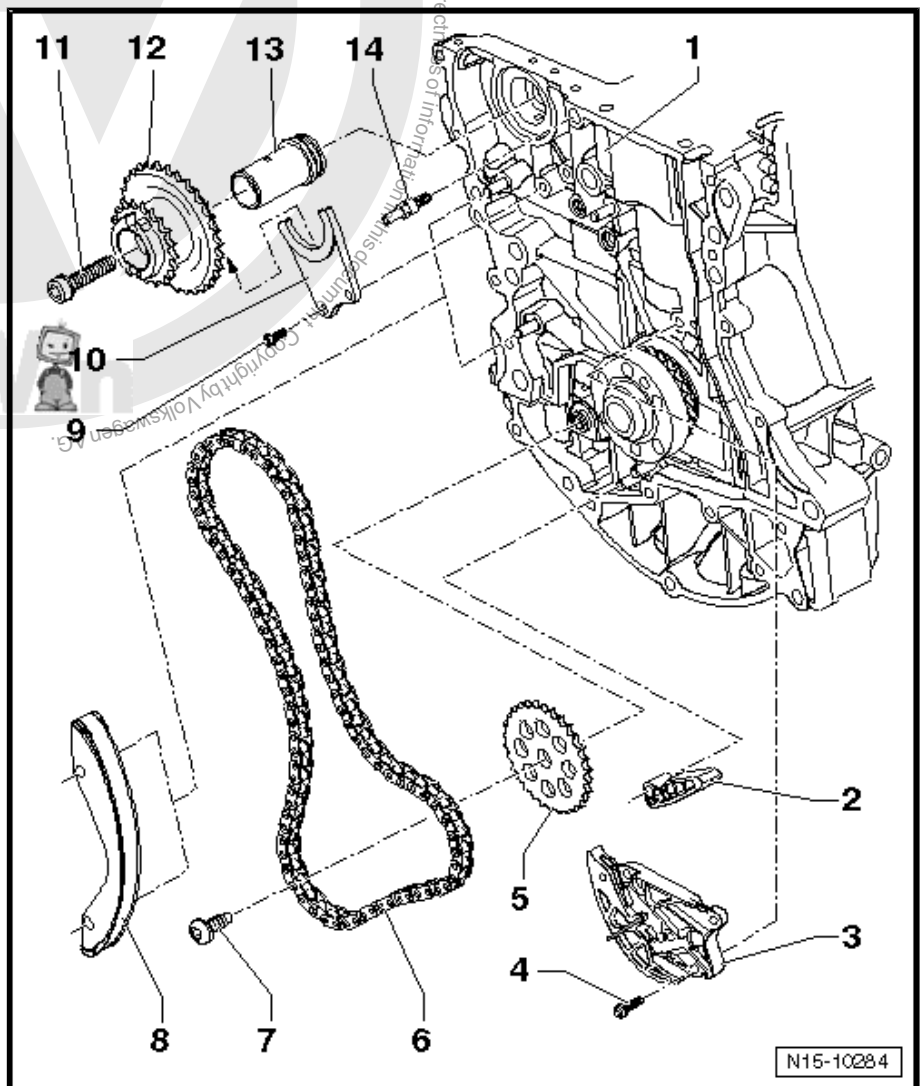



- Remove the timing chain.
- Remove the chain tensioner -3-.
- Mark the direction of travel.
- Note when installing:
 - Install in the original direction of rotation.
 - The chain must lie correctly in the tensioning and guide rails.
 - Adjust the valve timing. Refer to ["3.3 Valve Timing, Adjusting", page 75](#) .

7 - Bolt

- 20 Nm + an additional 90° (1/4) additional turn.
- Always replace.

8 - Guide Rail

- Oil before installing on the pin.

9 - Bolt

- 10 Nm

10 - Axial Bearing Disc

- Engages in the groove in the double sprocket -12-.

11 - Bolt

- 60 Nm + 90° (1/4) additional turn.
- Always replace.

12 - Camshaft and Oil Pump Timing Chains Double Sprocket

- Oil the journal before installing.
- Lubricate the axial bearing disc groove.

13 - Gear Shaft

14 - Threaded Pin

- 40 Nm
- For the camshaft timing chain tensioning rail.

1.5 Valvetrain Overview



Note

- ◆ *Cylinder heads with cracks between the valve seats, or between the valve seat and the spark plug threads, can continue to be used without reducing the service life, as long as the cracks have a Max. width of 0.3 mm, or only the first 4 threads of the spark plug threads are cracked.*
- ◆ *The cylinder head and guide frame must be replaced together.*
- ◆ *Do not grind the valve seats in the cylinder head. Only hand lapping the valves is permitted.*
- ◆ *Do not start the engine for approximately 30 minutes after installing the camshafts. The hydraulic lash adjusters must seat themselves (otherwise the valves will crash into the pistons).*
- ◆ *After working on the valvetrain and adjusters, carefully rotate the crankshaft by hand at least 2 full revolutions before starting to be sure that the valves do not strike the pistons.*
- ◆ *Always replace the gaskets and seals.*



1 - Bolt

- 8 Nm + an additional 90° (1/4) additional turn.
- Always replace.

2 - Guide Frame

- Removing and installing. Refer to ⇒ ["4.6 Camshaft", page 89](#) .
- With integrated camshaft bearings.
- Clean the sealing surface, reworking is not permitted.
- Remove any old sealant residue.

3 - Exhaust Camshaft Sprocket

4 - Bolt

- 60 Nm + an additional 90° (1/4) additional turn.
- Always replace.

5 - Bolt

- 60 Nm + an additional 90° (1/4) additional turn.
- Always replace.

6 - Intake Camshaft Adjuster

7 - Seals

- For the camshaft adjuster.
- Note the installed position. Refer to ⇒ ["4.6 Camshaft", page 89](#) .

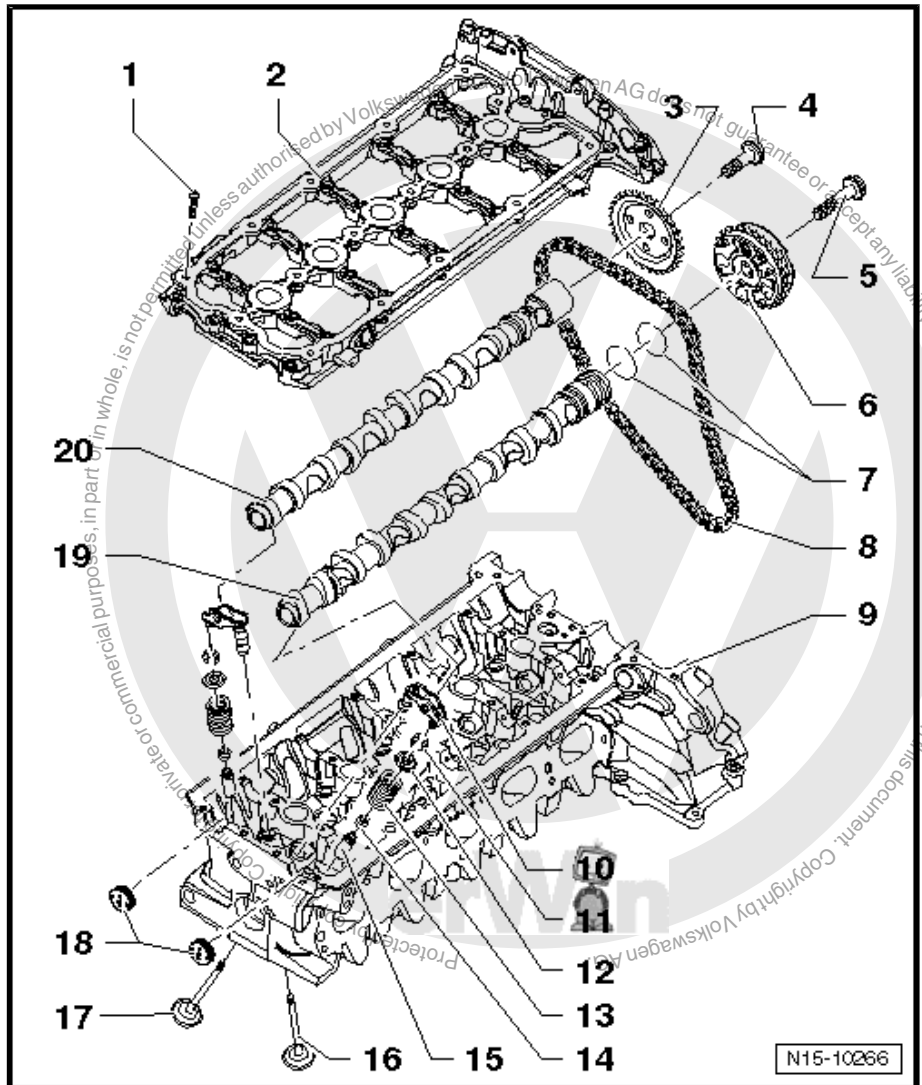

8 - Timing Chain

- Removing from the sprockets. Refer to ⇒ ["3.3 Valve Timing, Adjusting", page 75](#) .

9 - Cylinder Head

- Do not grind the valve seats, only hand lapping is permitted.

10 - Roller Rocker Arm with Hydraulic Lash Adjuster

- Do not interchange.
- Lubricate the contact surface.

11 - Valve Retainers

12 - Upper Spring Seat

13 - Valve Spring

14 - Valve Stem Seal

- Removing and installing. Refer to ⇒ ["4.7 Valve Shaft Seals", page 92](#) .

15 - Valve Guide

- Checking. Refer to ⇒ ["3.4 Valve Guide, Checking", page 78](#) .

16 - Intake Valve

- Do not grind, only hand lapping is permitted.
- Valve dimensions. Refer to ⇒ ["2.1 Valve Dimensions", page 71](#) .



- Valve guide, checking. Refer to ⇒ [“3.4 Valve Guide, Checking”, page 78](#) .

17 - Exhaust Valve

- Do not grind, only hand lapping is permitted.
- Valve dimensions. Refer to ⇒ [“2.1 Valve Dimensions”, page 71](#) .
- Valve guide, checking. Refer to ⇒ [“3.4 Valve Guide, Checking”, page 78](#) .

18 - Sealing Plug

- Always replace.
- Installing. Refer to ⇒ [“4.6 Camshaft”, page 89](#) .

19 - Intake Camshaft

- Removing and installing. Refer to ⇒ [“4.6 Camshaft”, page 89](#) .
- Check the radial clearance using Plastigage® (roller rocker arm is removed).

Wear limit: 0.1 mm

Run out: maximum 0.035 mm

Axial clearance: maximum 0.17 mm

20 - Exhaust Camshaft

- Removing and installing. Refer to ⇒ [“4.6 Camshaft”, page 89](#) .
- Check the radial clearance using Plastigage® (roller rocker arm is removed).

Wear limit: 0.1 mm

Run out: maximum 0.035 mm

Axial clearance: maximum 0.17 mm





2 Specifications

⇒ [“2.1 Valve Dimensions”, page 71](#)

⇒ [“2.2 Fastener Tightening Specifications”, page 71](#)

2.1 Valve Dimensions



Note

Intake and exhaust valves must not be refaced by grinding. Only hand lapping is permitted.

Dimension		Intake Valve	Exhaust Valve
Diameter a	mm	32.25 to 32.45	27.90 to 28.10
Diameter b	mm	5.97 to 5.99	5.93 to 5.95
c	mm	103.90 to 104.00	101.85 to 101.90
α	$^{\circ}$	45	45

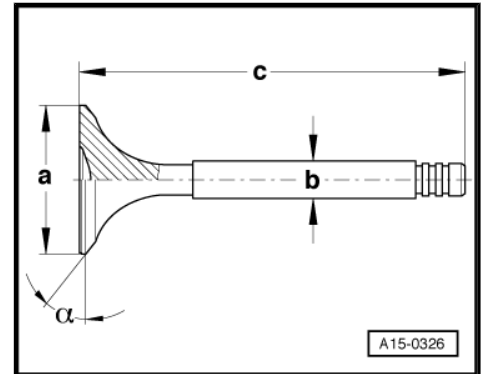

2.2 Fastener Tightening Specifications

Cylinder Head Cover Bolt Tightening Sequence and Specification

- Tighten the bolts in the sequence shown to 10 Nm.

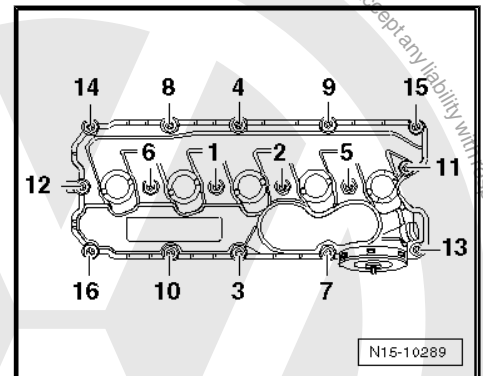

Cylinder Head Bolt Tightening Sequence and Specification

- Install the cylinder head bolts and tighten them hand tight.
- Tighten the cylinder head bolts -1 through 12- in the sequence shown as follows:

Step	Tighten
1	– Tighten the bolts to 40 Nm, using a torque wrench.
2	– Tighten the bolts an additional 90° (1/4) turn, using a ratchet.
3	– Tighten the bolts an additional 90° (1/4) turn, using a ratchet.

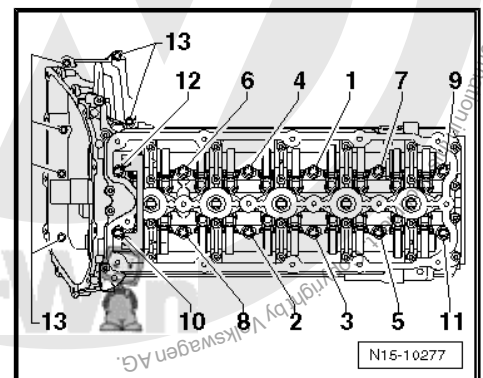

- Then tighten bolts -13- to 10 Nm.



3 Diagnosis and Testing

⇒ [“3.1 Compression Pressure, Checking”, page 72](#)

⇒ [“3.2 Valve Timing, Checking”, page 73](#)

⇒ [“3.3 Valve Timing, Adjusting”, page 75](#)

⇒ [“3.4 Valve Guide, Checking”, page 78](#)

3.1 Compression Pressure, Checking

Special tools and workshop equipment required

- ◆ Spark Plug Removal Tool - 3122B-
- ◆ Ignition Coil Puller - T40039-
- ◆ Torque Wrench (5-50 Nm) - VAG1331-
- ◆ Compression Tester - VAG1763-
- ◆ Adapter - VAG1381/5A-

Test Conditions

- The engine oil temperature must be at least 30 °C (86 °F).
- The voltage supply is OK.
- Remove the engine cover with air filter. Refer to
 ⇒ [“5.1 Engine Cover with Air Filter”, page 159](#) .
- Disconnect the connectors from all the fuel injectors.
- Remove the ignition coils with power output stage. Refer to
 ⇒ [“3.1 Ignition Coil with Power Output Stage”, page 199](#) .
- Remove the spark plugs using the Spark Plug Removal Tool - 3122B- .
- Check the compression using the Compression Tester - VAG1763- and the Adapter - VAG1381/5A- .



Note

Using the compression tester. Refer to the operating instructions.

- Operate the starter until the tester no longer indicates that the pressure is increasing.

Compression Pressure

New Positive Pressure	Wear Limit Positive Pressure	Difference Between Cylinders Positive Pressure
9.0 to 13.0 bar (130 to 188.5 psi)	8 bar (116 psi)	Max. 3 bar (43 psi)



Note

By disconnecting the connectors, Diagnostic Trouble Codes (DTCs) are stored to memory. After the test, check the DTC memory and erase, if necessary.

- Read the Engine Control Module (ECM) DTC memory. Refer to the vehicle diagnostic tester.



3.2 Valve Timing, Checking

Special tools and workshop equipment required

- ◆ Torque Wrench (5-50 Nm) - VAG1331-
- ◆ Crankshaft Adapter - T03003-
- ◆ Locking Pin - T40069-
- ◆ Camshaft Clamp - T40070-

Procedure

- Remove the cylinder head cover. Refer to [⇒ "4.1 Cylinder Head Cover", page 79](#) .
- Remove the noise insulation. Refer to ⇒ Body Exterior; Rep. Gr. 50 ; Description and Operation .
- Remove the front section of the right wheel housing liner. Refer to ⇒ Body Exterior; Rep. Gr. 66 ; Removal and Installation .
- Install the Crankshaft Adapter - T03003- onto the vibration damper bolts.

The Crankshaft Adapter - T03003- can only be installed correctly in one position.

- Rotate the crankshaft in engine rotation direction until the arrow -A- on the Crankshaft Adapter - T03003- faces downward vertically in comparison to the engine axis. This position corresponds approximately to the crankshaft Top Dead Center (TDC) position.

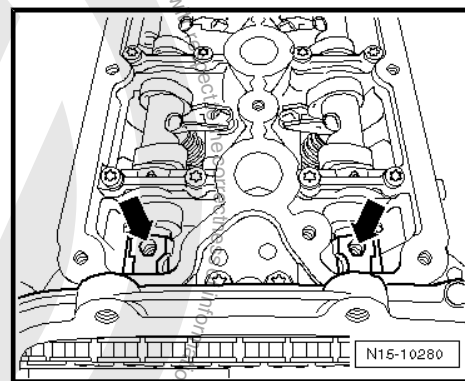
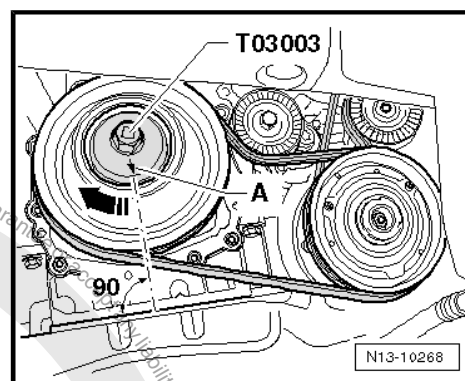

Note

If the threaded holes in the camshafts -arrows- do not point upward, the crankshaft must be rotated one rotation (360°) in engine rotation direction.



- Remove the locking bolt -1- from the rear of the cylinder block.
- Look through the hole and check whether the bore -2- in the crankshaft aligns with the threaded hole.

Use a mirror to do so.

- If the hole and bore align, install the Locking Pin - T40069- completely into the threaded hole and tighten it to 10 Nm.

If the crankshaft was rotated out past the TDC mark:

- Rotate the crankshaft back 45° in the opposite direction of engine rotation.
- Then, rotate the crankshaft again into the TDC position in engine rotation direction.

When the crankshaft is positioned slightly in front of the TDC position (the bore in the crankshaft is 90% visible), the Locking Pin - T40069- can be installed, although slightly more difficult.

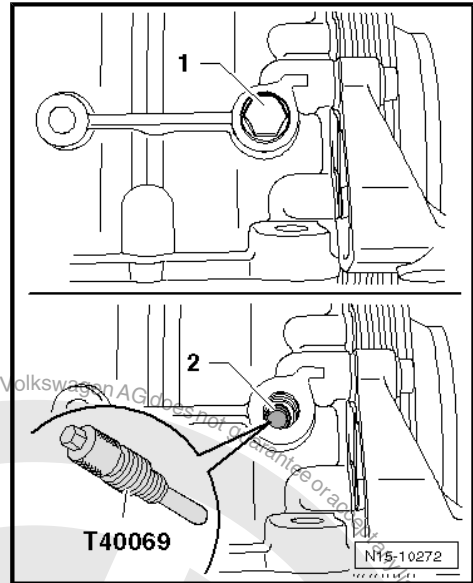

Note

With the engine removed, the TDC mark can also be seen on the vibration damper and belt pulley side sealing flange. The notches -A- and B- must align.

- Check whether the crankshaft can be rotated.

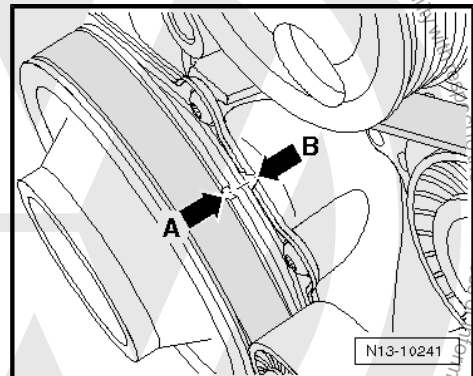

The valve timing is correct when the Camshaft Clamp - T40070- bolts can be installed easily into the ends of the camshafts as shown. The support surfaces of the Camshaft Clamp - T40070- must lie flat on the flats of the camshafts when doing this.

- If the bolts are difficult to install, install an 18 or 19 mm open end wrench -A- onto the flat on the exhaust camshaft and rotate the camshaft slightly in the direction of the arrow- to remove any play in the chain.

If the bolts for the Camshaft Clamp - T40070- can now be installed easily with the chain tensioned in this manner, the valve timing is also correct. Possibly the crankshaft was not secured correctly.

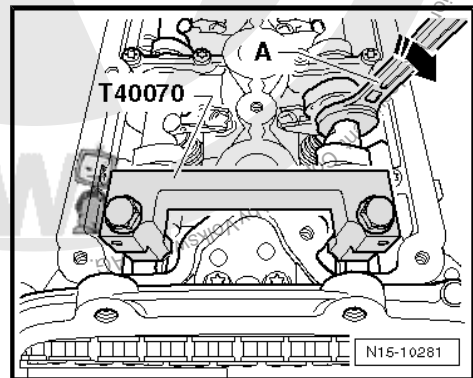

If the Camshaft Clamp - T40070- Cannot Be Installed

The valve timing is incorrect when the Camshaft Clamp - T40070- bolts cannot be installed easily into the ends of the camshafts despite the tensioned chain.

- ◆ In this case, the valve timing must be adjusted. Refer to ⇒ ["3.3 Valve Timing, Adjusting", page 75](#) .

After Disassembly and Assembly Work



- Remove the Locking Pin - T40069- and install the locking bolt -1- to the rear of the cylinder block.

The rest of the installation follows the reverse of the removal procedure.

Tightening Specifications

Component	Nm
Locking bolt to rear of cylinder block	30 Nm

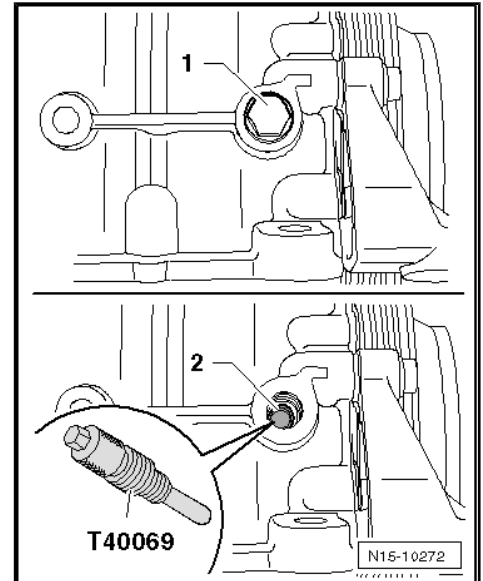

3.3 Valve Timing, Adjusting

Special tools and workshop equipment required

- ◆ Torque Wrench (5-50 Nm) - VAG1331-
- ◆ Torque Wrench (40-200 Nm) - VAG1332-
- ◆ Locking Pins - T03006-
- ◆ Multipoint Socket - T10035-
- ◆ Counterhold Tool - T10172-
- ◆ Camshaft Clamp - T40070-
- ◆ 2 M8 x 16 Bolts

Modifying the Counterhold Tool - T10172-

- Unscrew the Adapter - T10172/1- and screw in the 2 M8 x 16 bolts -A-.



Note

The valve timing must be adjusted if the camshaft sprocket or adjuster were loosened during repairs or if the valve timing is not set.

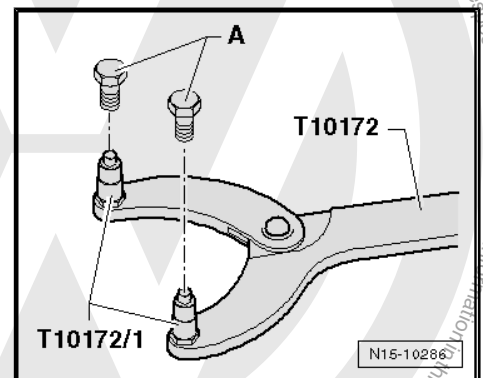

Securing the Camshafts if the Valve Timing is Correct

- Remove the timing chain cover. Refer to ⇒ [“4.4 Timing Chain Cover”, page 86](#) .
- Remove the cylinder head cover. Refer to ⇒ [“4.1 Cylinder Head Cover”, page 79](#) .
- Secure the crankshaft as described in the “valve timing, checking” procedure. Refer to ⇒ [“3.2 Valve Timing, Checking”, page 73](#) .



- Install the Camshaft Clamp - T40070- as shown onto the camshafts and tighten the bolts to 20 Nm.

If the bolts are difficult to install, install an 18 or 19 mm open end wrench -A- to the opening on the exhaust camshaft and rotate the camshaft slightly in the direction of the -arrow- to remove any play in the chain.

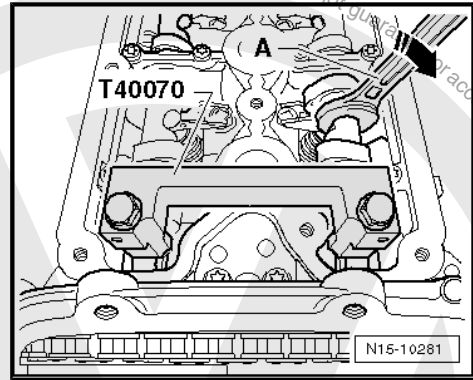

- Relieve the tension on the timing chain. To do so, insert a screwdriver of appropriate size between the piston for the chain tensioner and tensioning rail and press the screwdriver in the direction of -arrow-.

- Secure the completely pressed in piston using the Locking Pin - T03006- . the pin must be inserted until it stops.

Securing the Camshafts if the Valve Timing is not Correct

- Remove the timing chain cover. Refer to [⇒ "4.4 Timing Chain Cover", page 86](#) .
- Rotate the crankshaft to Top Dead Center (TDC) for cylinder 5. Refer to [⇒ "2.8 Crankshaft, Locking", page 36](#) . Do not lock the crankshaft using the Locking Pin - T40069- .

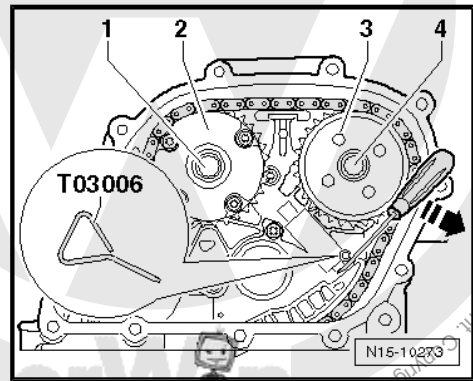

- Rotate the crankshaft so that the Camshaft Clamp - T40070- can be installed easily onto the camshafts as shown.
- Tighten bolts for the Camshaft Clamp - T40070- to 20 Nm.

Remove the Camshaft Sprocket or Adjuster

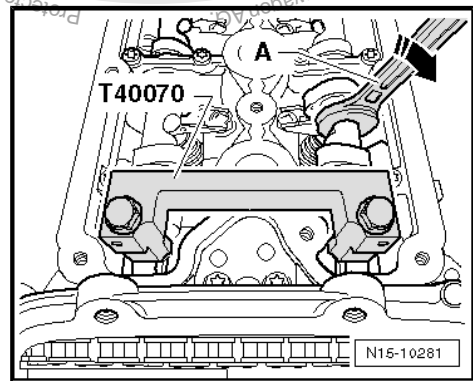



- Relieve the tension on the timing chain. To do so, insert a screwdriver of appropriate size between the piston of the chain tensioner and tensioning rail and press the screwdriver in the direction of the -arrow-.
 - Secure the completely pressed in piston using the Locking Pin - T03006- . The pin must be inserted until it stops.
 - Remove the bolts -1 and 4- using the Multipoint Socket - T10035- and remove the actuator -2- and the sprocket -3-.
- If necessary, the sprocket -3- must be pryed off lightly using a screwdriver.

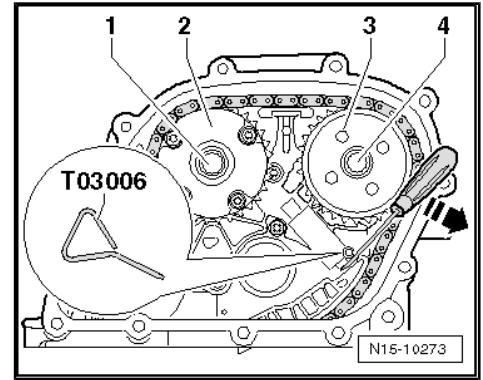

i Note

Lock the crankshaft. Refer to ["2.8 Crankshaft, Locking"](#), page 36 if not yet locked. The crankshaft must only be rotated slightly around the TDC point for this. Otherwise there is a risk the valves will rest on the pistons.

Adjusting the Timing

- The crankshaft is locked using the Locking Pin - T40069-
 - The camshafts are secured by the Camshaft Clamp - T40070-
 - The chain tensioner is tensioned
- Place the adjuster -2- and sprocket -3- in the timing chain as illustrated. Position the adjuster and sprocket onto the camshafts and install new bolts -1 and 4- and tighten them by hand.
- The adjuster and sprocket must still be able to be rotated, however they must not tilt.

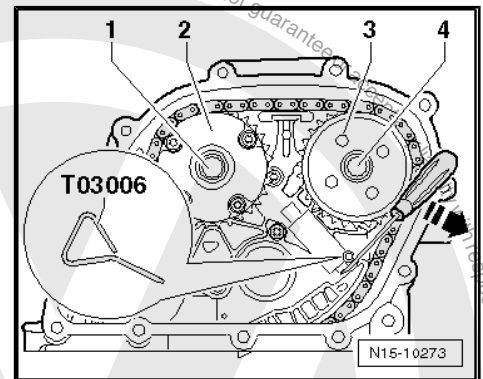

i Note

Make sure that timing chain lies correctly in the tensioning and guide rails.

- Relieve the tension on the chain tensioner by pressing in the piston and pulling out the Locking Pin - T03006- .
- Attach the modified Counterhold Tool - T10172- to the exhaust camshaft sprocket -4-.

i Note

A second technician is needed for the following steps.

- Hold the timing chain at preload by pressing the Counterhold Tool - T10172- in the direction of the -arrow-
 - Tighten the bolt -2- for the intake camshaft adjuster and then the bolt -3- for the exhaust camshaft sprocket to 60 Nm.
- Then, tighten the bolts -2 and 3- an additional 90° (1/4) turn.

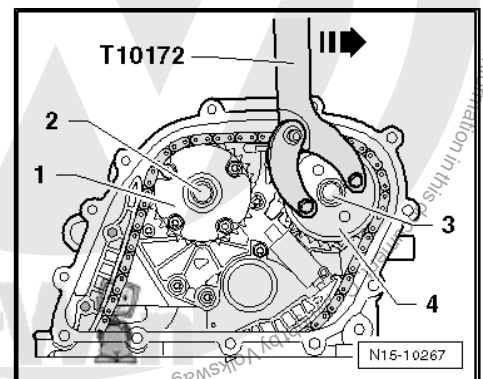

i Note

When applying the additional 90° torque angle, the timing chain must no longer be held at preload.



- Remove the Camshaft Clamp - T40070- .

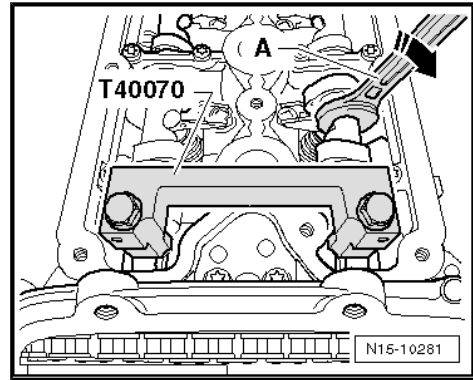

- Remove the Locking Pin - T40069- for securing the crankshaft.
- Turn the crankshaft 2 turns in engine rotation direction and check the valve timing. Refer to [⇒ "3.2 Valve Timing, Checking", page 73](#) .

If the valve timing is not correct:

- Loosen the intake camshaft adjuster and exhaust camshaft sprocket bolts again and adjust the valve timing again (replace the bolts).

The rest of the installation follows the reverse of the removal procedure. Note the following:

- ◆ Remove the Locking Pin - T40069- from the rear of the cylinder block and install the locking bolt.
- ◆ Fill the coolant. Refer to [⇒ "1.1 Coolant, Draining and Filling", page 121](#) .

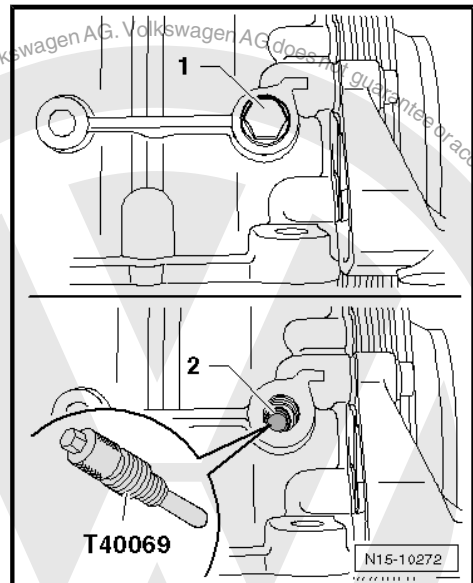

3.4 Valve Guide, Checking

Special tools and workshop equipment required

- ◆ Universal Dial Gauge Mount - MP3-447-
- ◆ Dial Gauge
- Insert the new valve into the guide. The tip of the valve stem must seal with the guide. Due to differences in valve stem diameter, make sure that only intake valves are used to check intake valve guides, and only exhaust valves are used to check exhaust valve guides.
- Determine the tilt clearance.

Wear limit: 0.8 mm

If the tilt clearance is exceeded:

- Replace the cylinder head.

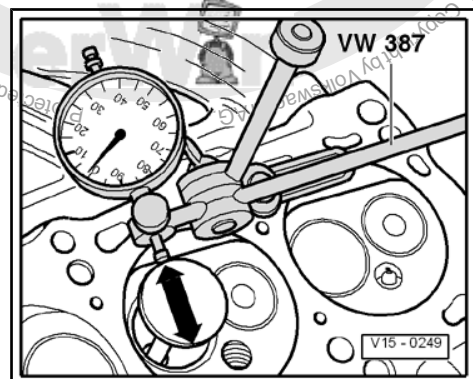



4 Removal and Installation

- ⇒ [“4.1 Cylinder Head Cover”, page 79](#)
- ⇒ [“4.2 Cylinder Head”, page 80](#)
- ⇒ [“4.3 Vacuum Pump”, page 84](#)
- ⇒ [“4.4 Timing Chain Cover”, page 86](#)
- ⇒ [“4.5 Timing Chain Cover Seal”, page 88](#)
- ⇒ [“4.6 Camshaft”, page 89](#)
- ⇒ [“4.7 Valve Shaft Seals”, page 92](#)

4.1 Cylinder Head Cover

Special tools and workshop equipment required

- ◆ Torque Wrench - VAG1331-

Removing

- Remove the engine cover with air filter. Refer to [“5.1 Engine Cover with Air Filter”, page 159](#) .
- Disconnect crankcase ventilation hose -arrow-.
- Remove the Secondary Air Injection (AIR) pipe -A-, if equipped.
- Remove the ignition coils -1 through 5-. Refer to [“3.1 Ignition Coil with Power Output Stage”, page 199](#) .

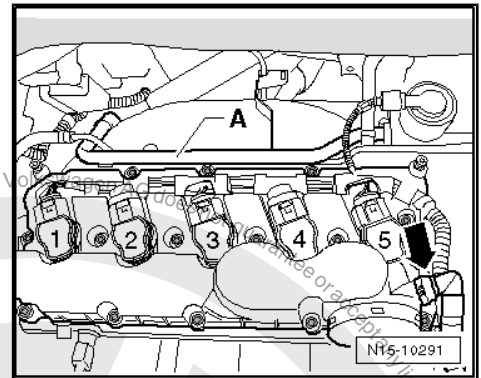

- Remove the cylinder head cover bolt in sequence -16 through 1-.

Installing

Install in the reverse order of removal. Note the following:

Note

Replace the cylinder head cover if damaged or leaking.

- Clean the sealing surfaces so they are completely free of any oil or grease.
- Tighten the cylinder head cover bolts in sequence -1 through 16-.
- Follow the correct tightening sequence when installing the AIR pipe -A-, if necessary. Refer to [Fig. “AIR Pipe Bolt Tightening Sequence”, page 179](#) .

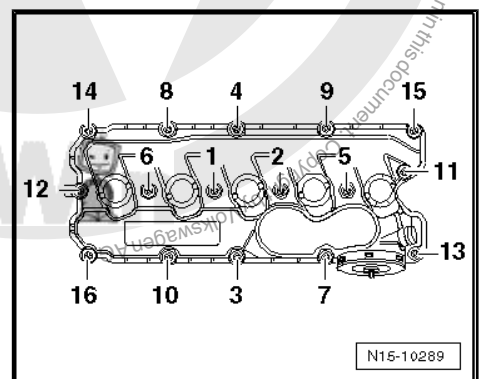
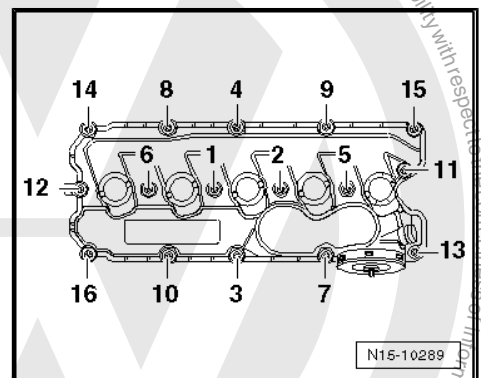

Component	Nm
Cylinder head cover to cylinder head	10
AIR pipe at cylinder head	10



4.2 Cylinder Head



Note

- ◆ *When installing a replacement cylinder head, all of the contact surfaces between the hydraulic lash adjusters, roller rocker arms and cam running surfaces on the camshaft must be lubricated before installing the cylinder head cover.*
- ◆ *Only remove the plastic protectors installed to protect the open valves immediately before fitting the cylinder head.*
- ◆ *Replace the cylinder head bolts.*
- ◆ *When replacing the cylinder head or cylinder head gasket, the coolant must be completely replaced.*

Special tools and workshop equipment required

- ◆ Drip Tray for VAS6100 VAS6208-
- ◆ Torque Wrench (5-50 Nm) - VAG1331-
- ◆ Torque Wrench (40-200 Nm) - VAG1332-
- ◆ Spring Type Clip Pliers - VAS6499-
- ◆ Polydrive Bit and Drive Socket - T10070-
- ◆ Ignition Coil Puller - T40039-
- ◆ Silicone Sealant - D174003A2-



Caution

When doing any repair work, especially in the engine compartment, pay attention to the following due to clearance issues:

- ◆ *Route all lines and wires in their original locations.*
- ◆ *Make sure there is enough clearance to moving or hot components to prevent damage to the lines.*

Removing

- Drain the coolant. Refer to [⇒ "1.1 Coolant, Draining and Filling", page 121](#) .
- Remove the engine cover with air filter. Refer to [⇒ "5.1 Engine Cover with Air Filter", page 159](#) .
- Remove the battery. Refer to ⇒ Electrical Equipment; Rep. Gr. 27 ; Removal and Installation .



- Remove the cover -1- for the E-box and remove the wire -2-.
- Remove the bolts -arrows- and remove the battery tray from the vehicle.



WARNING

Hot steam may escape when opening the expansion tank cap. Wear protective goggles and protective clothing to prevent damage to eyes and scalding. Cover the cap with a cloth and open very carefully.

- Remove the intake manifold. Refer to [⇒ "5.3 Intake Manifold", page 161](#) .
- Install the transport strap back onto the cylinder head in order to better hold the cylinder head during removal.
- Remove the timing chain cover. Refer to [⇒ "4.4 Timing Chain Cover", page 86](#) .
- Remove the cylinder head cover. Refer to [⇒ "4.1 Cylinder Head Cover", page 79](#) .
- Secure the camshafts and remove the adjuster and sprocket from the camshafts. Refer to [⇒ "3.3 Valve Timing, Adjusting", page 75](#) .
- Hold the timing chain -A- as shown, so it can be routed below the coolant pipe connection -arrow-.

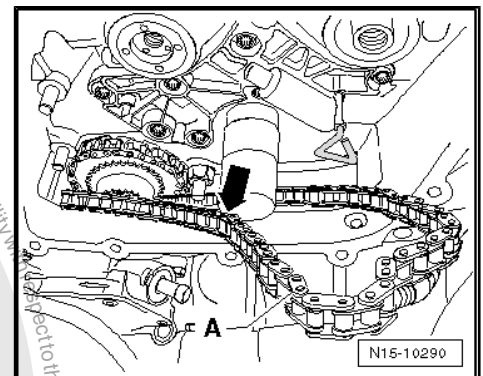
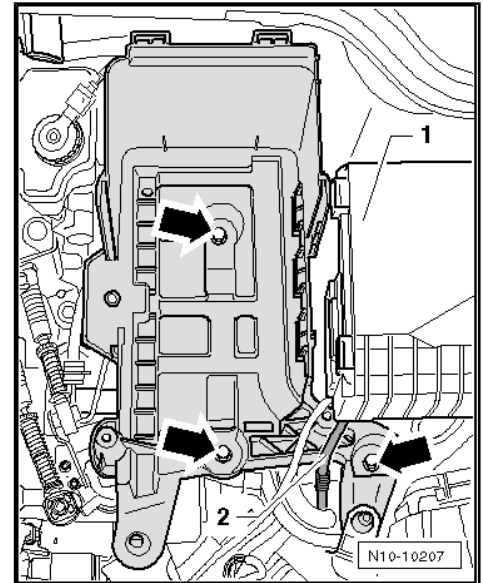

- Remove the 4 exhaust pipe with catalytic converter to exhaust manifold nuts -2- and the suspended mount bolts -3-.
- Remove the exhaust pipe with catalytic converter -1- from the manifold and tie it up firmly to the side. Refer to [⇒ "4.3 Exhaust Pipe with Catalytic Converter", page 189](#) .



Note

The coupling element in the exhaust pipe with catalytic converter must not be bent more than 10°, otherwise it may be damaged.

- Disconnect the connector for the Heated Oxygen Sensor -G39- at the bulkhead.

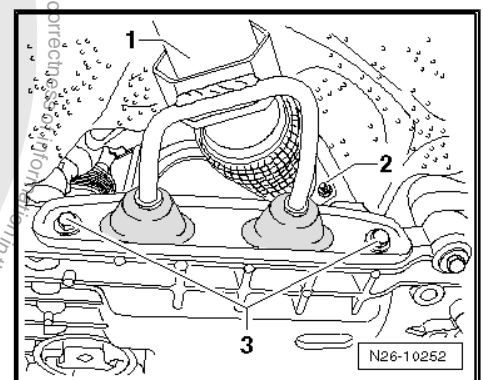



- Remove the wire bracket -3- bolts -arrows- at the Secondary Air Injection (AIR) valve.

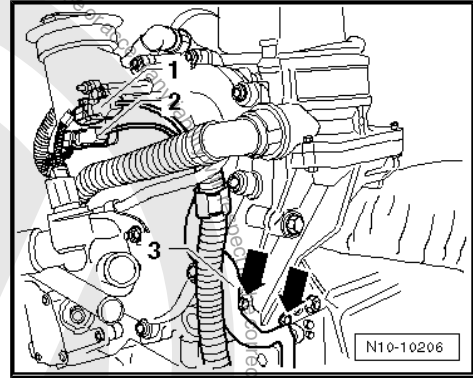

- Remove the cylinder head bolts in the specified sequence.



Note

- ◆ If the bolt -2- cannot be removed with a magnet, loosen the Camshaft Clamp - T40070- bolts one turn. Slide the Camshaft Clamp - T40070- forward and to the right and tighten the bolts again.
- ◆ A second technician is required to remove and install the cylinder head.

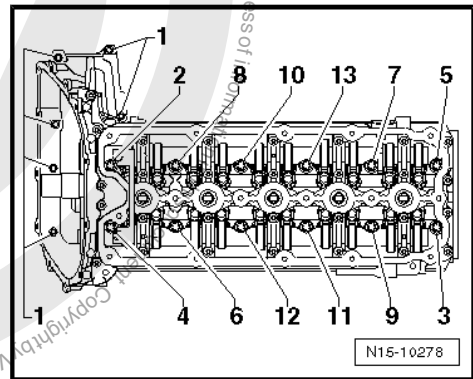

- Carefully remove the cylinder head.

Installing



Note

- ◆ There must be no oil or coolant in the blind holes for the cylinder head bolts in the cylinder block.
- ◆ Only remove the new cylinder head gasket from its packaging immediately before installing.
- ◆ Handle the new gasket with extreme care. Damaging will lead to leaks.
- ◆ Replace the cylinder head bolts.
- Insert clean cloths into the cylinder bores and chain compartment so that no dirt or abrasive powder can penetrate between the cylinder wall and piston and into the chain compartment.
- Do not allow dirt or abrasive powder to get into the coolant either.
- Carefully clean the cylinder head and cylinder block sealing surfaces. Avoid scratching or scoring (do not use sandpaper with grit below 100).
- Carefully remove any metal particles, emery remains and the cloths.



- Cut the sealant tube nozzle at the front mark (nozzle diameter: approximately 1 mm).
 Note the shelf life date.

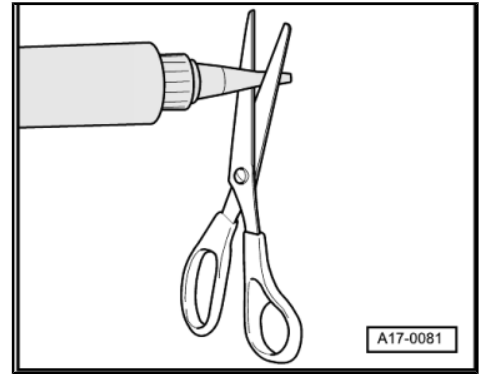

- Apply a bead of sealant -1- (front and rear) on the clean sealing surfaces as shown.
- ◆ The sealant bead must be 2.0 to 2.5 mm thick.
- Install the new cylinder head gasket -2-.

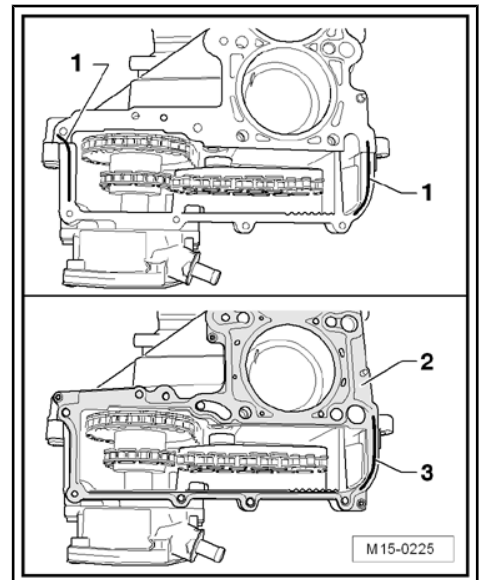

- Note the centering pins -arrows- in the cylinder block.
- Apply a bead of sealant -3- (rear only), as illustrated, on the cylinder head gasket.
- ◆ The sealant bead must be 2.0 to 2.5 mm thick.

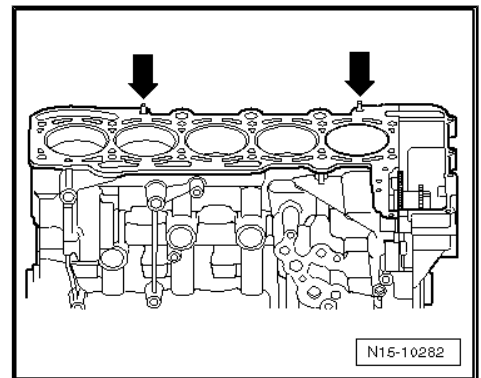

i Note

The cylinder head must be installed within 5 minutes of being applied with sealant.

- Install the cylinder head.
- Guide the timing chain over the coolant pipe connection.
- Insert the cylinder head bolts and tighten them hand tight.

Protected by copyright. Copying for private or commercial purposes, in part or in whole, is not permitted unless authorised by Volkswagen AG. Volkswagen AG does not guarantee or accept liability with respect to the correctness of information in this document.





- Then, tighten the cylinder head bolts -1 through 12- in sequence as shown:

Stage	Tighten
1	- Tighten the bolts to 40 Nm, using a torque wrench.
2	- Tighten the bolts an additional 90° (1/4) turn, using a ratchet.
3	- Tighten the bolts an additional 90° (1/4) turn, using a ratchet.

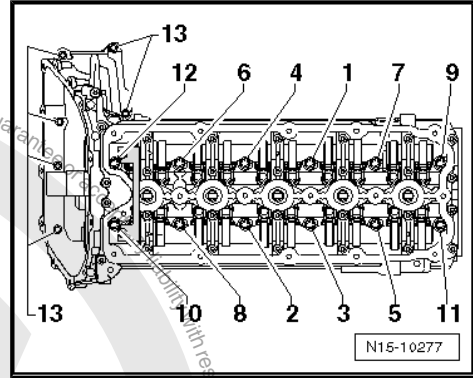

- Then, tighten the bolts -13- to 10 Nm.
- Wipe off any excess sealant, which has leaked out.

The rest of the installation follows the reverse of the removal procedure. Note the following:

- ◆ Remove the Locking Pin - T40069- from the rear of the cylinder block and install the locking bolt.
- ◆ Replace and fill the coolant. Refer to ⇒ ["1.1 Coolant, Draining and Filling", page 121](#) .
- ◆ Install the battery. Refer to ⇒ Electrical Equipment; Rep. Gr. 27 ; Removal and Installation .

4.3 Vacuum Pump

Special tools and workshop equipment required

- ◆ Torque Wrench (5-50 Nm) - VAG1331-



Note

Due to installation conditions, the transmission must be removed on vehicles with a automatic transmission.

Removing

- Remove the engine cover with air filter. Refer to ⇒ ["5.1 Engine Cover with Air Filter", page 159](#) .
- Remove the battery. Refer to ⇒ Electrical Equipment; Rep. Gr. 27 ; Removal and Installation .
- Remove the cover -1- for the E-box and remove the wire -2-.
- Remove the bolts -arrows- and remove the battery tray.

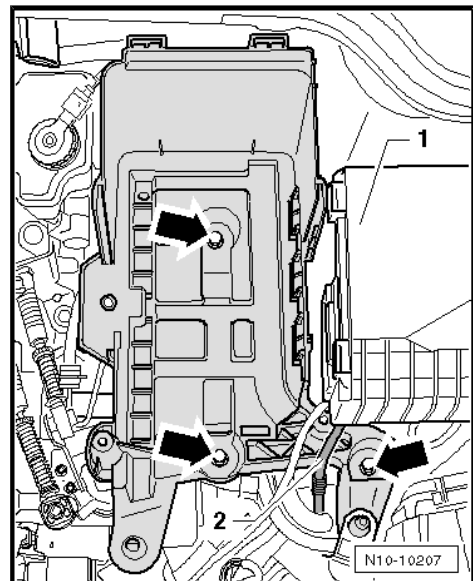



- Remove intake air duct bolts -arrows- and duct from the lock carrier.

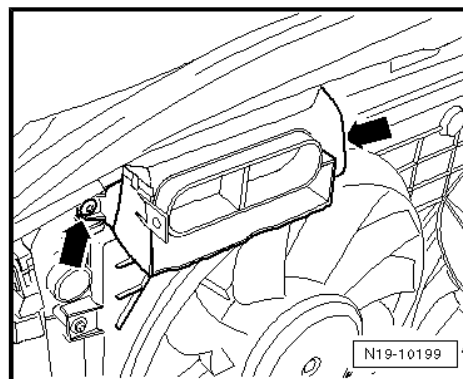

- Remove the connecting pipe -4-. To do so, disconnect the connecting pipe -1-, if equipped with Secondary Air Injection (AIR), and the vent tube -2- and reposition the spring clamp -3-.

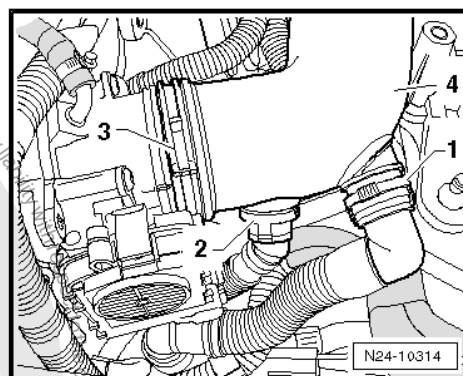

Disconnect the wiring harness from the bracket -2-.

Remove the bolt -3- for the coolant pipe.

- Disconnect the vacuum hose -1-.
- Remove the 3 bolts -arrows- and the vacuum pump.

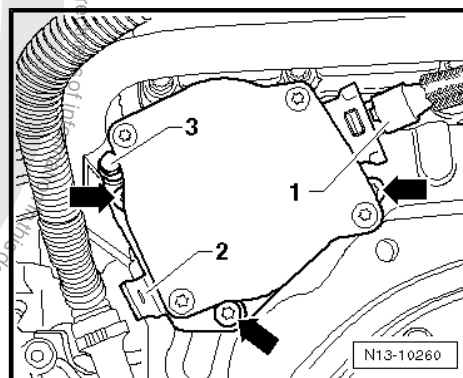

Note
 The 4 cover bolts **MUST NOT** be loosened under any circumstances!

- Remove the old gasket.

Installing

- Place the new gasket -2- on the vacuum pump.
- Position the vacuum pump coupling plate -3- so it engages in the symmetrical groove on the double sprocket -1- when installing the vacuum pump -arrows-.
- Install and tighten vacuum pump bolts.

The rest of the installation follows the reverse of the removal procedure.

- Install the battery. Refer to ⇒ Electrical Equipment; Rep. Gr. 27 ; Removal and Installation .

Tightening Specification

Component	Nm
Vacuum pump to sealing flange, transmission side	10
Coolant pipe to bracket	10

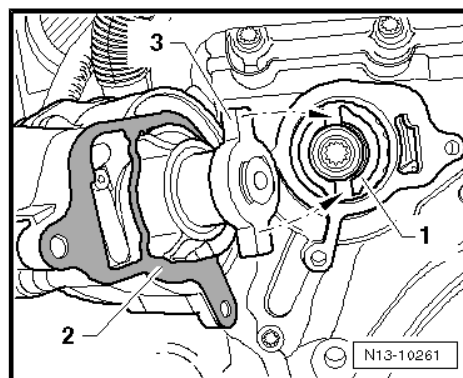



4.4 Timing Chain Cover

Special tools and workshop equipment required

- ◆ Trim Removal Wedge - 3409-
- ◆ Torque Wrench (5-50 Nm) - VAG1331-
- ◆ Hand Drill with Plastic Brush Attachment
- ◆ Protective Eyewear
- ◆ Silicone Sealant - D174003A2



Caution

When doing any repair work, especially in the engine compartment, pay attention to the following due to clearance issues:

- ◆ *Route all lines and wires in their original locations.*
- ◆ *Make sure there is enough clearance to moving or hot components to prevent damage to the lines.*

Removing

- Remove the engine cover with air filter. Refer to ⇒ ["5.1 Engine Cover with Air Filter", page 159](#) .
- Remove the battery. Refer to ⇒ Electrical Equipment; Rep. Gr. 27 ; Removal and Installation .
- Remove the cover -1- for the E-box and remove the wire -2-.
- Remove the bolts -arrows- and remove the battery tray.



WARNING

Hot steam may escape when opening the expansion tank cap. Wear protective goggles and protective clothing to prevent damage to eyes and scalding. Cover the cap with a cloth and open very carefully.

- Drain the coolant. Refer to ⇒ ["1.1 Coolant, Draining and Filling", page 121](#) .
- Remove the intake manifold. Refer to ⇒ ["5.3 Intake Manifold", page 161](#) .
- Remove the coolant pipe at the coolant thermostat housing and the bracket on the vacuum pump.
- Pull out the retaining clip -arrow- and remove the coolant pipe -A-.

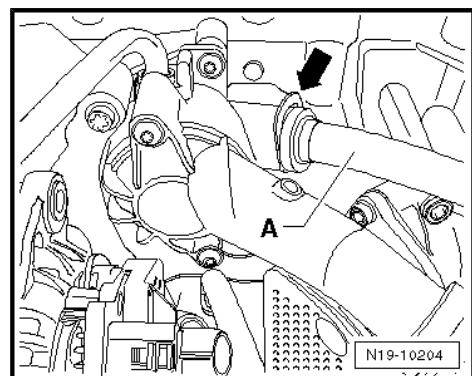
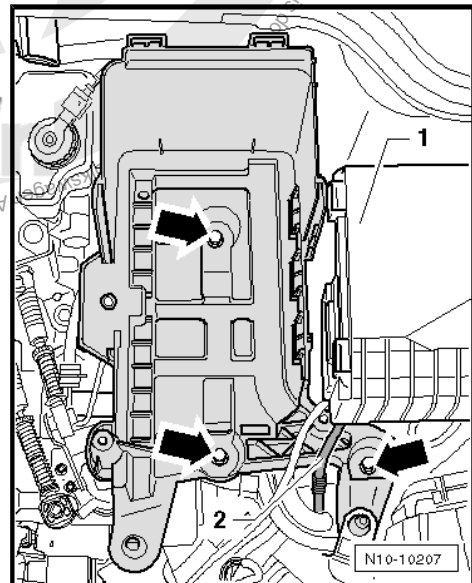



- Disconnect the connectors -1 and 3-.
- Disconnect the connecting pipe -2- from the Secondary Air Injection (AIR) valve.
- Remove the rear coolant pipe -4-.
- Disconnect the vacuum hose -6- from the vacuum pump and disconnect the connector -7-.
- Remove the brackets -8 and 9- and lay aside the wiring harness with the pressure pipe.
- Press the bracket for the knock sensor wiring harness at the AIR valve slightly toward the rear.
- Remove the flange -5- and set it aside with the coolant hoses connected.
- Remove the timing chain cover bolts.
- Pry off the timing chain cover -1- from the cylinder head -2- uniformly at the top and bottom recesses.

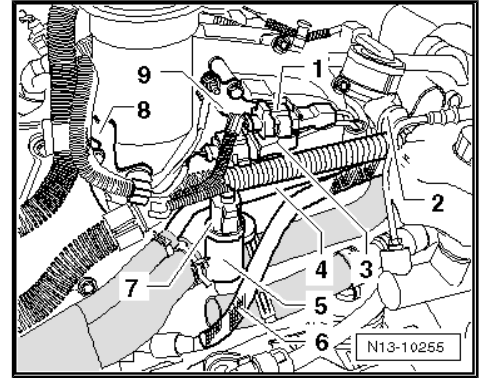

Note

- ◆ *The sealing surfaces must not be damaged under any circumstances. If necessary, use the Trim Removal Wedge - 3409- .*
- ◆ *After removing the timing chain cover, clean the Trim Removal Wedge - 3409- which is intended for the removal of interior equipment parts.*

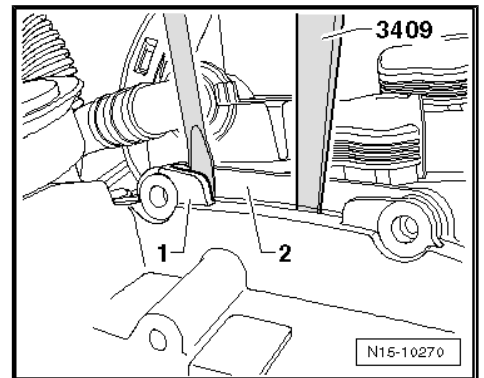

Installing



WARNING

To prevent injuries from shavings, wear protective goggles and protective clothing.

- Remove the remainder of sealant from the timing chain cover and from the cylinder head, using for example, a rotating plastic brush.



Caution

Make sure that no sealant residue enters the engine.

- Clean the coolant pipe connection on the cylinder head. If necessary, remove any coolant deposits with a copper wire brush or fine sandpaper (minimum 100 grit). If the pipe connection is worn, replace it using Liquid Locking Fluid - D000600A2- .
- Replace the seal in the timing chain cover. Refer to ["4.5 Timing Chain Cover Seal", page 88](#) .
- Replace the seal in the coolant flange.
- Clean the sealing surfaces so they are completely free of any oil or grease.



- Cut the sealant tube nozzle at the front mark (nozzle diameter: approximately 1 mm).

i Note

The timing chain cover must be installed within 5 minutes after application of the sealant.

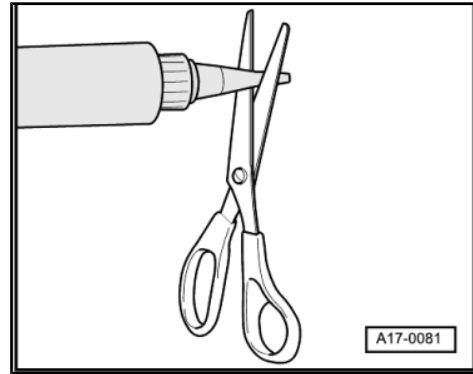

- Apply the sealant bead -A- as shown onto the clean sealing surface of the timing chain cover.
- ◆ The sealant bead must be 1.5 to 2.0 mm thick.
- Coat the seal for the timing chain cover lightly with engine oil and slide the cover onto the coolant pipe connection.
- Install all the bolts and tighten them in a diagonal sequence.

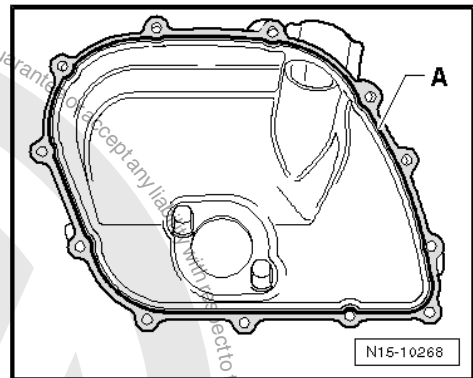

The rest of the installation follows the reverse of the removal procedure. Note the following:

- Fill the coolant. Refer to ⇒ ["1.1 Coolant, Draining and Filling", page 121](#).
- Install the battery. Refer to ⇒ Electrical Equipment; Rep. Gr. 27 ; Removal and Installation .

Tightening Specifications

Component	Nm
Timing chain cover to cylinder head	10
Flange to the timing chain cover	10

4.5 Timing Chain Cover Seal

Conditions

- The timing chain cover is removed.

Special tools and workshop equipment required

- ◆ Arbor - VW195-
- ◆ Tube 60 mm Dia. - VW415A-
- ◆ Fitting Sleeve - 3241/4-

Driving Out the Seal

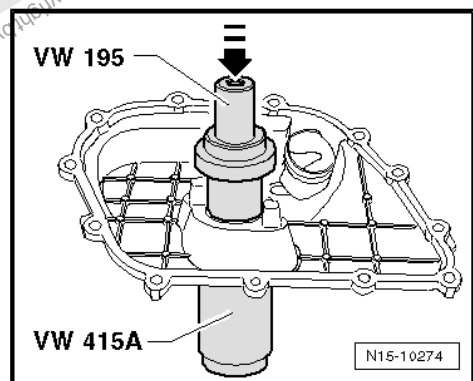



Driving in the Seal

- Support the timing chain cover with supports -arrows- on a firm surface and press in the new seal until it is seated.

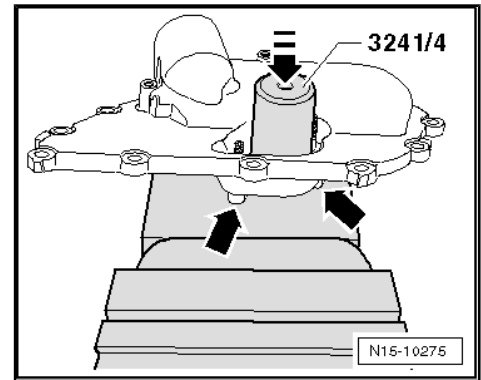

4.6 Camshaft

Special tools and workshop equipment required

- ◆ Torque Wrench (5-50 Nm) - VAG1331-
- ◆ Hand Drill with Plastic Brush Attachment
- ◆ Protective Eyewear
- ◆ Sealant - D154103A1-

Removing



Note

- ◆ *The sealing surfaces on the bottom of the guide frame and on the top of the cylinder head must not be reworked.*
 - ◆ *The camshaft bearings are integrated in the cylinder head and in the guide frame. Before removing the guide frame, the adjuster and sprocket on the camshafts must be removed.*
 - ◆ *If the guide frame was loosened, the sealing plugs must be replaced.*
- Secure the camshafts and remove the adjuster and sprocket from the camshafts. Refer to [⇒ "3.3 Valve Timing, Adjusting", page 75](#).

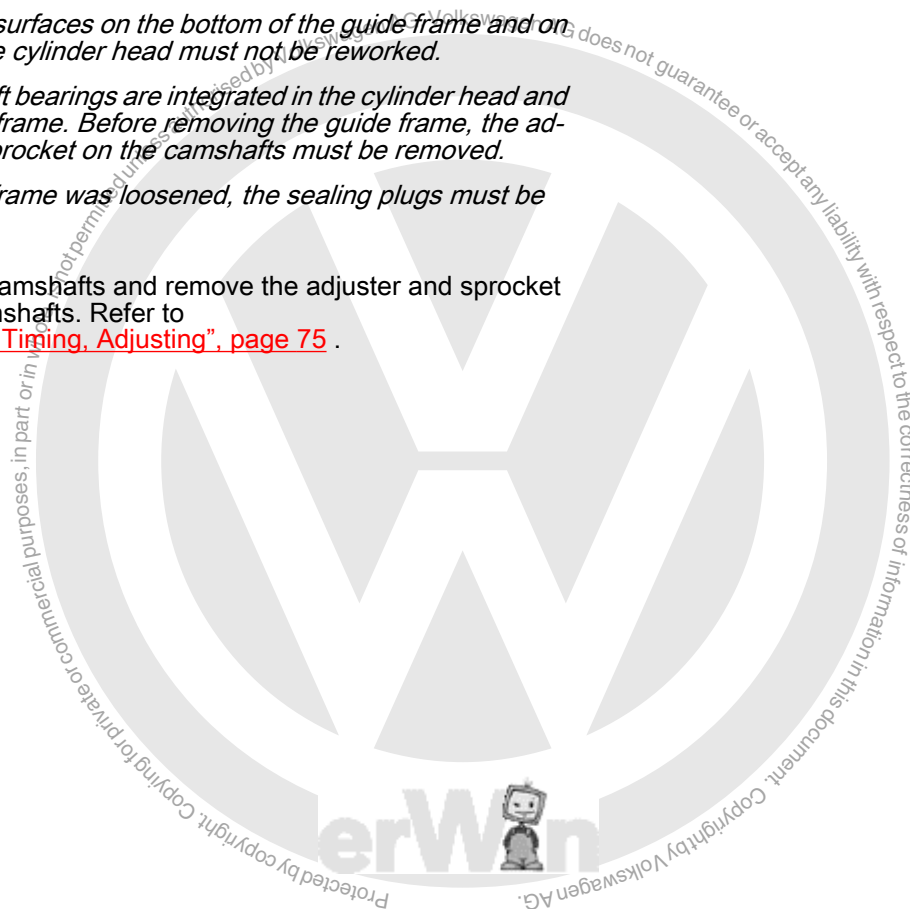



- Then, remove the Camshaft Clamp - T40070- .
- Remove the guide frame bolts evenly working from the outside toward the inside and remove the guide frame.
- Carefully remove the camshafts upward and place them on a clean surface.

Installing



WARNING

To prevent injuries from shavings, wear protective goggles and protective clothing.

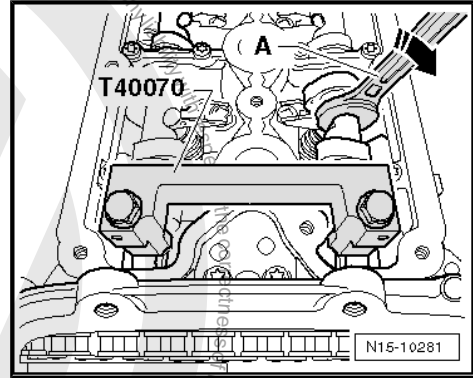

- Remove the remainder of the sealant from the guide frame (out of the grooves as well) and from the cylinder head, using for example, a rotating plastic brush.



Caution

Make sure that no sealant residue enters the engine.



- Clean the sealing surfaces, they must be free of oil and grease.
- Oil the journal surfaces of the camshafts.
- Place the guide frame on a soft surface.
- Insert the camshafts correctly into the guide frame.
- ◆ The intake camshaft with the sensor wheel -2- faces toward the Camshaft Position Sensor - G40- -1-.
- ◆ The camshafts must lie exactly in the axial bearings -3- of the guide frame.
- ◆ The ends of the seals -4 and 5- must face up or down. They must not face to the side.
- Turn over the guide frame slightly with the camshafts installed, hold the camshafts firmly in place in the guide frame while doing this.

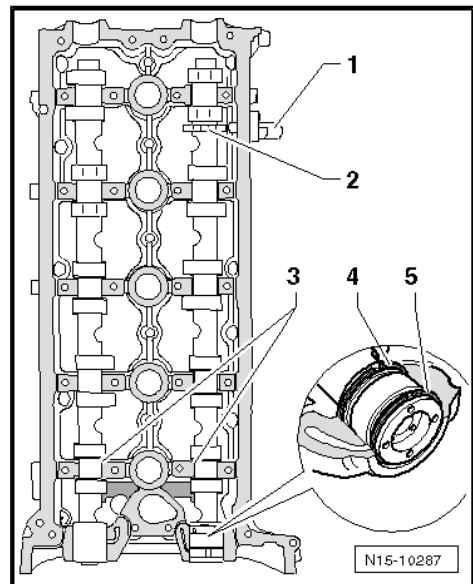

- Rotate the camshafts until the threaded holes -arrows- point upward.
- Check whether the camshafts still lie exactly in the axial bearings of the guide frame.

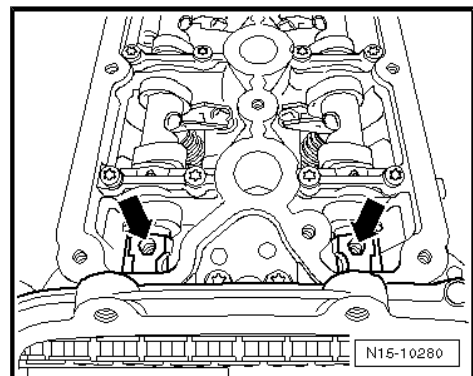



- Install the Camshaft Clamp - T40070- as shown to the camshafts and tighten the bolts to 20 Nm.
- Turn over the guide frame again.

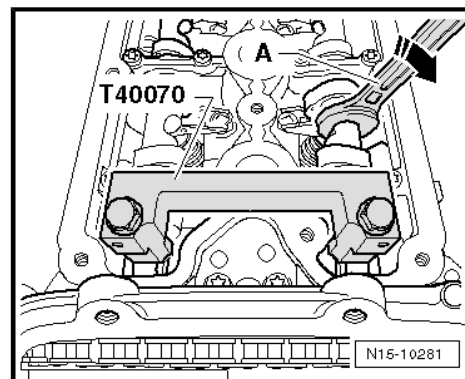

- Cut the sealant tube nozzle at the front mark (nozzle diameter: approximately 1 mm).

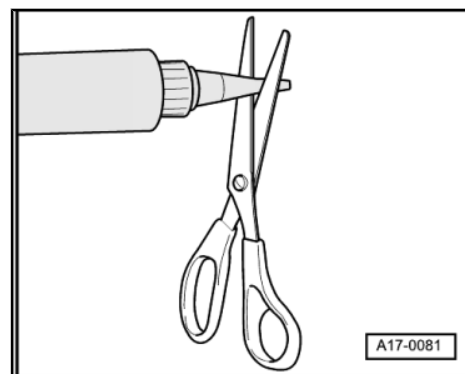

- Lightly apply an even bead of sealant into the clean grooves of the guide frame -1 through 8-

Width of sealant bead:

- ◆ Grooves -1 through 5-: approximately 3.0 mm
- ◆ Grooves -6 through 8-: approximately 4 mm



Note

- ◆ *The sealant beads must be applied according to exact specifications, otherwise the excess sealant could get into the camshaft bearings.*
- ◆ *Installing and securing the guide frame should be performed without interruption because the sealant begins to harden immediately as soon as it contacts the sealing surfaces.*
- ◆ *Note the expiration date of the sealant.*
- Place the guide frame onto the cylinder head immediately.
- Gently tighten the bolts working from the inside toward the outside in several stages.

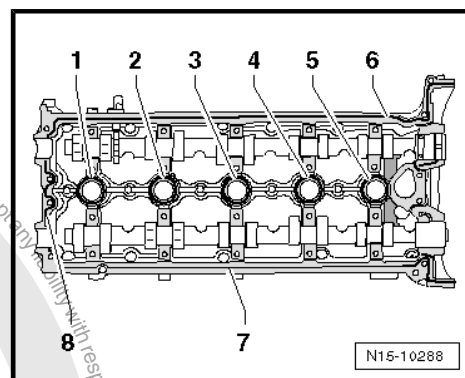

Protected by copyright. Copying for private or commercial purposes, in part or in full, is not permitted unless authorised by Volkswagen AG. Volkswagen AG does not guarantee or accept any liability with respect to the correctness of information in this document.





- Then, tighten the bolts to 8 Nm in the sequence indicated.
- After that, tighten all the bolts an additional 90° (1/4) turn.

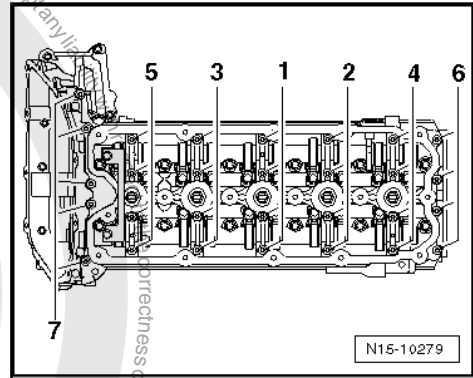

- The sealant must squeeze out slightly, even in the chain compartment area -arrows-.
- Wipe off the excess sealant on the sealing surface facing the timing chain cover.

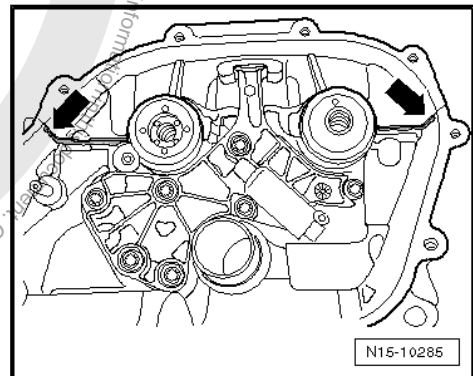

- Carefully press in the sealing plugs -A- until they reach the end of the chamfer -arrows-.

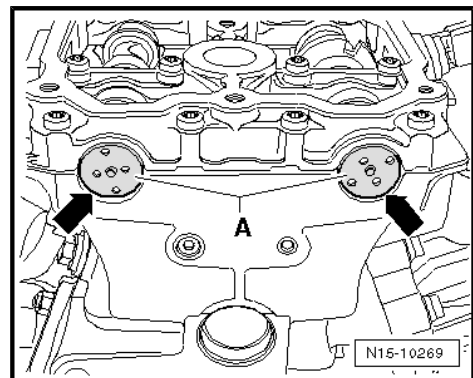

i Note

If a sealing plug was pressed in too far, it must be pressed through and pressed in again up to the mark.

The rest of the installation follows the reverse of the removal procedure. Note the following:

- ◆ Remove the Locking Pin - T40069- from the rear of the cylinder block and install the locking bolt (30 Nm).
- ◆ Fill the coolant. Refer to [⇒ "1.1 Coolant, Draining and Filling", page 121](#) .

4.7 Valve Shaft Seals

(With the cylinder head installed)

Special tools and workshop equipment required

- ◆ Spark Plug Removal Tool - 3122B-
- ◆ Valve Seal Removal Tool - 3364-
- ◆ Valve Stem Seal Driver - 3365-
- ◆ Adapter - T40012-
- ◆ Torque Wrench (5-50 Nm) - VAG1331-
- ◆ Valve Cotters Asm/Disasm Device - VAS5161-
- ◆ Guide Plate for FSI Engine - VAS5161/19B-

Removing

To remove the valve stem seals on some valves, the following components must be removed:

- ◆ For the intake valves in cylinder 1: The transport strap
- ◆ For the intake valves in cylinder 5: The Camshaft Adjustment Valve 1 - N205-
- ◆ For the exhaust valves in cylinder 5: The Secondary Air Injection Solenoid Valve - N112-

- Remove the camshafts. Refer to ⇒ [“4.6 Camshaft”, page 89](#) .
- Remove the roller rocker arms and lay them on a clean surface. Make sure that the rocker arms are not interchanged.
- Remove the spark plugs using the Spark Plug Removal Tool - 3122B- .

Install the Guide Plate for FSI Engine - VAS5161/19B- to the cylinder head using the Knurled Thumb Screws M6 - VAS5161/12- .

- Adjust the piston of the respective cylinder to the Bottom Dead Center (BDC) position.
- Install the Adapter - T40012- into the spark plug threads and connect the compressed air hose (minimum 6 bar (87 psi)).

- Loosen any stuck valve retainers using the Punch - VAS5161/3- and a plastic mallet.

- Install the Retainer - VAS5161/6- with the Guide Forks M6/M8 with Threaded Studs - VAS5161/5- into the Guide Plate for FSI Engine - VAS5161/19B- .
- Insert the Assembly Cartridge - VAS5161/8- into the Guide Plate for FSI Engine - VAS5161/19B- .
- Engage the Pressure Fork with Lever for Assembly Cartridge - VAS5161/2- on the retainer - VAS5161/6- .

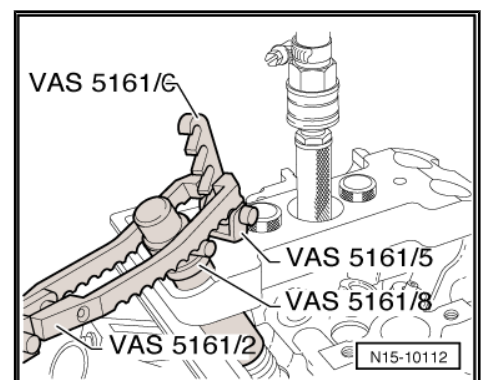
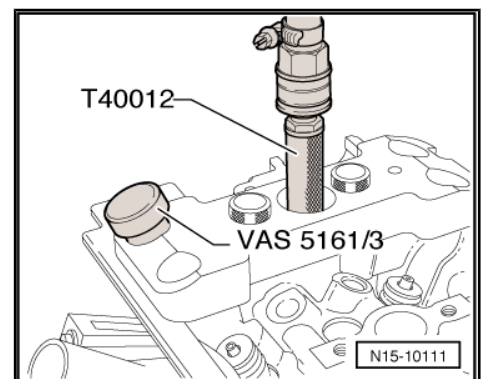
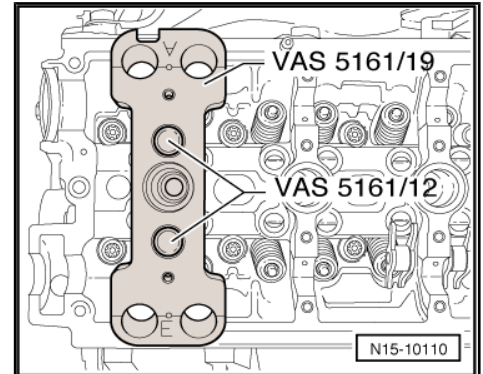



Note

The Pressure Fork with Lever for Assembly Cartridge - VAS5161/2- must engage on the exhaust side as illustrated.

- Press down the Assembly Cartridge - VAS5161/8- . At the same time, turn the knurled thumb screw on the Assembly Cartridge - VAS5161/8- clockwise until the points engage in the valve retainers.
- Lightly move the knurled thumb screw on the assembly cartridge back and forth, this causes the valve retainers to be pressed apart and captured in the assembly cartridge.
- Release the Pressure fork with Lever for Assembly Cartridge - VAS5161/2- .
- Remove the Assembly Cartridge - VAS5161/8- , valve spring retainers and valve springs.
- Remove the valve stem seal using the Valve Seal Removal Tool - 3364- .

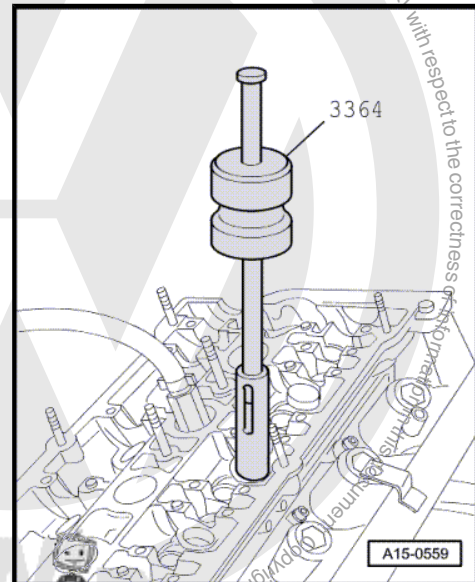
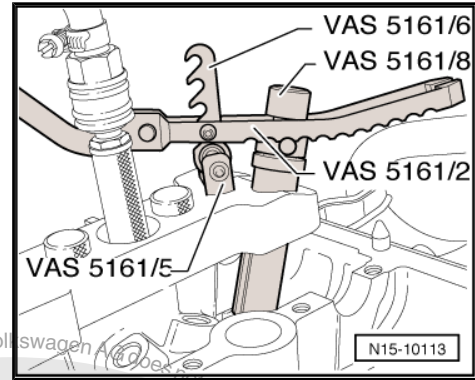

- If there is not enough clearance to use the Valve Seal Removal Tool - 3364- , drive the roll pin -arrow- out using a drift and remove the impact attachment.
- Place the lower part of the Valve Seal Removal Tool - 3364- onto the valve stem seal.
- Insert the drift -1- into the bore in the lower part of the removal tool.

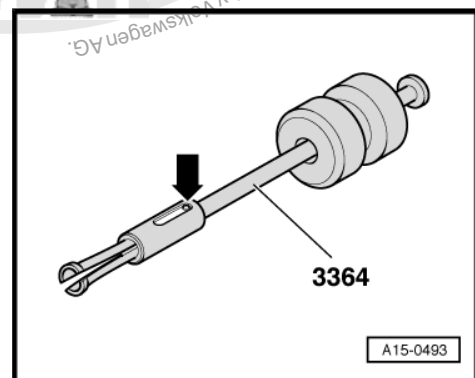



- Using the drift as a lever, pull out the valve stem seal in the direction of the -arrow-.

Installing

Place the plastic sleeve -A- on the valve stem to prevent damage to the new valve stem seal -B-.

- Oil the sealing lip of the valve stem seal -B-, insert it into the Valve Stem Seal Driver - 3365- and carefully slide it onto the valve guide.

Remove the plastic sleeve -A-.

Insert the valve spring and valve spring retainers.

- Install the Valve Cotters Asm/Disasm Device - VAS5161- components as illustrated.

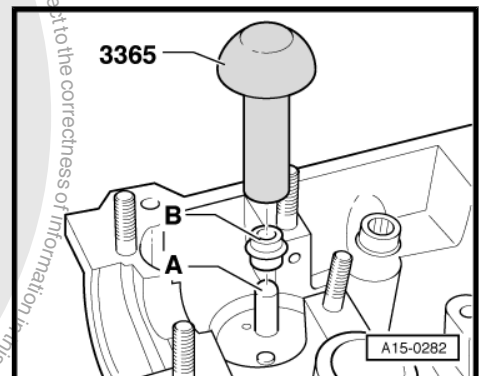
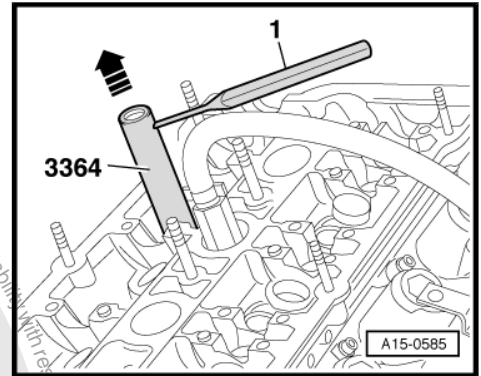

Intake Side

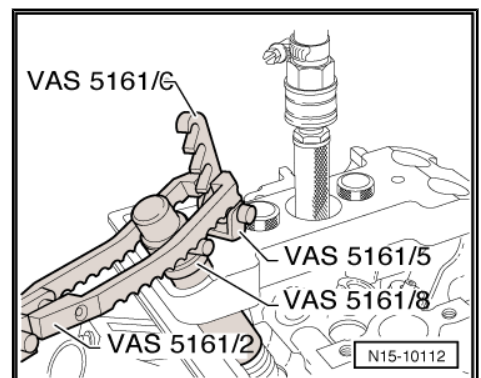

Exhaust Side

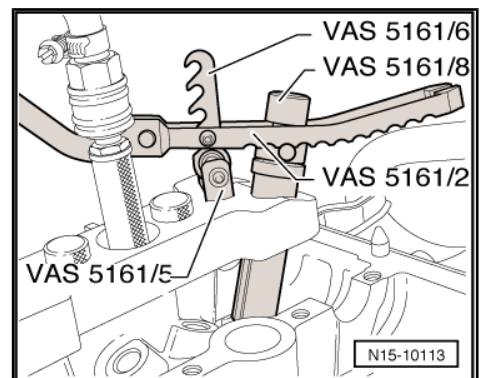

Protected by copyright. Copying for private or internal purposes, in part or in whole, is not permitted unless authorised by Volkswagen AG. Volkswagen AG does not guarantee or accept any liability with respect to the correctness of information in this document. Copyright by Volkswagen AG.



Note

- ◆ *If the valve retainers were removed from the assembly cartridge, they must be inserted into the Valve Insertion Device - VAS5161/18- next.*
- ◆ *Press the Assembly Cartridge - VAS5161/8- onto the valve insertion device from above and take up the valve retainers.*
- Press the Assembly Cartridge - VAS5161/8- with the Pressure Fork With Lever For Assembly Cartridge - VAS5161/2- down. Tap lightly against the lower area of the assembly cartridge. Rotate the knurled thumb screw on the assembly cartridge back and forth and pull it upward.
- Release the Pressure Fork with Lever for Assembly Cartridge - VAS5161/2- with the knurled thumb screw pulled.
- Remove the Valve Cotters Asm/Disasm Device - VAS5161- components.

The rest of the installation follows the reverse of the removal procedure. Note the following:

- ◆ Remove the Locking Pin - T40069- from the rear of the cylinder block and install the locking bolt.
- ◆ Fill the coolant. Refer to ["1.1 Coolant, Draining and Filling", page 121](#).

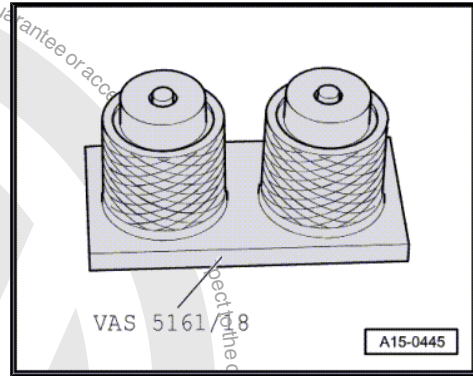



5 Special Tools

Special tools and workshop equipment required

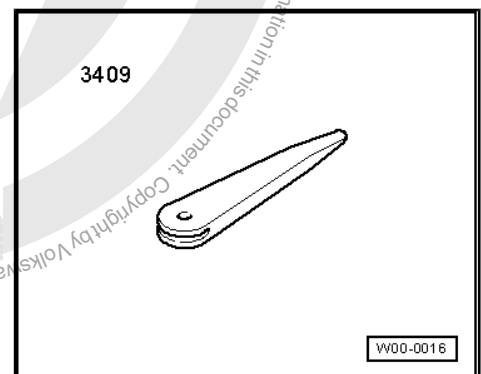
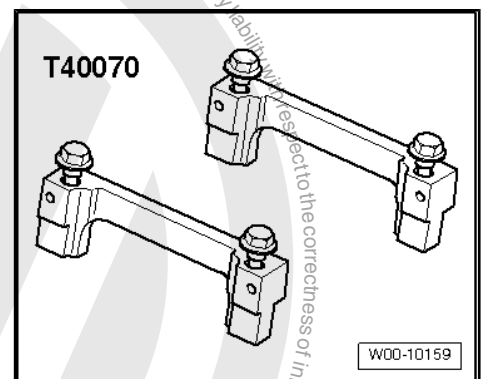

- ◆ Universal Dial Gauge Mount - MP3-447-
- ◆ Crankshaft Adapter - T03003-
- ◆ Locking Pin - T40069-
- ◆ Torque Wrench (40-200 Nm) - VAG1332-
- ◆ Locking Pins - T03006-
- ◆ Multipoint Socket - T10035-
- ◆ Counterhold Tool - T10172-
- ◆ Drip Tray for VAS6100 - VAS6208-
- ◆ Spring Type Clip Pliers - VAS6499-
- ◆ Polydrive Bit and Drive Socket - T10070-
- ◆ Valve Seal Removal Tool - 3364-
- ◆ Valve Stem Seal Driver - 3365-
- ◆ Adapter - T40012-
- ◆ Valve Cotters Asm/Disasm Device - VAS5161-
- ◆ Guide Plate for FSI Engine - VAS5161/19B-
- ◆ Camshaft Clamp - T40070-

- ◆ Trim Removal Wedge - 3409-



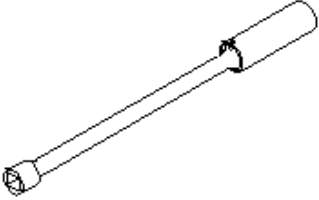
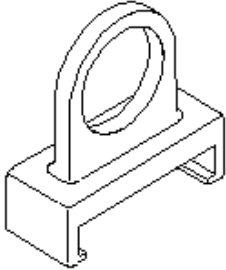

- ◆ Spark Plug Removal Tool - 3122B-
- ◆ Ignition Coil Puller - T40039-
- ◆ Torque Wrench (5-50 Nm) - VAG1331-
- ◆ Compression Tester - VAG1763-
- ◆ Adapter - VAG1381/5A-

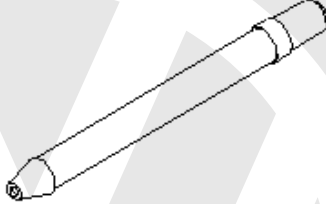
<p>3122 B</p> 	<p>T40039</p> 
<p>V.A.G 1331</p> 	<p>V.A.G 1763</p> 
<p>V.A.G 1381/5A</p> 	<p>W15-10051</p>

Protected by copyright. Copying for private or commercial purposes, in part or in whole, is not permitted unless authorised by Volkswagen AG. Volkswagen AG does not guarantee or accept any liability with respect to the correctness of information in this document. Copyright by Volkswagen AG.





- ◆ Arbor - VW195-
- ◆ Tube 60 mm Dia. - VW415A-
- ◆ Fitting Sleeve - 3241/4-

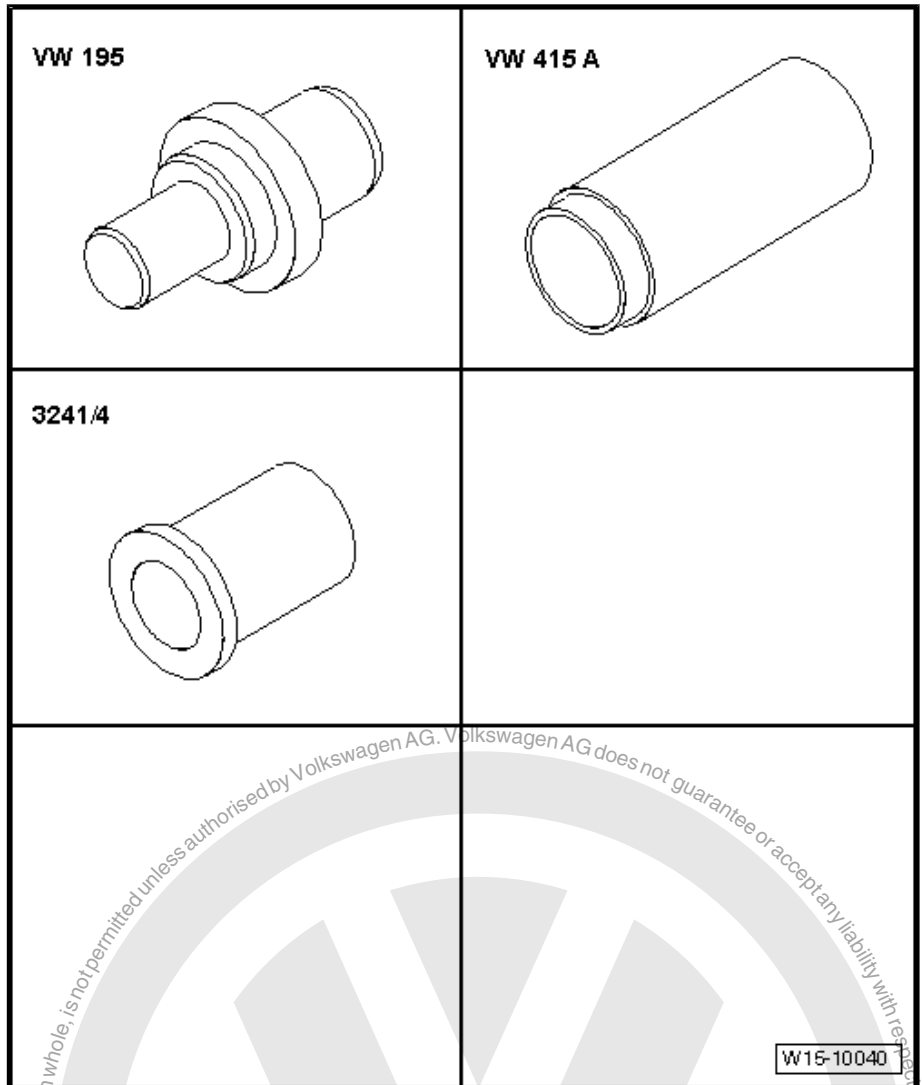



17 – Lubrication

1 General Information

⇒ [“1.1 Engine Oil”, page 100](#)

⇒ [“1.2 Oil Filter Housing, Draining”, page 100](#)

1.1 Engine Oil

Oil Capacity

For the engine oil capacity. Refer to the Fluid Capacity Tables, Rep. Gr. 03.

Viscosity Class and Oil Specification

For the viscosity class and specification. Refer to the Fluid Capacity Tables, Rep. Gr. 03.

Oil Dipstick Marks

1 - MAX. mark

2 - MIN. mark

a - Oil level in area of the MAX. mark: Do not add engine oil.

b - Oil level in the center area: Oil can be added.

c - Oil level in area of the MIN. mark: Add approximately 0.5 liter (0.52 quart) of engine oil.

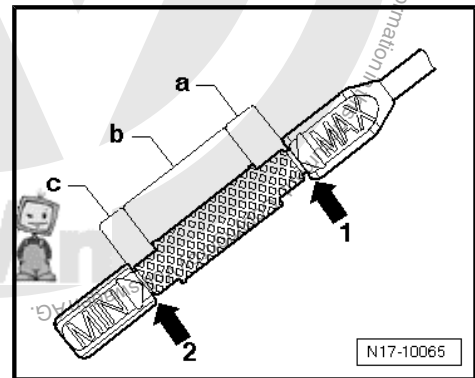

1.2 Oil Filter Housing, Draining



Note

When installing the Oil Drain Adapter - T40057-, a valve in the oil filter housing is opened. If the oil drain adapter - T40057- is removed, the valve is closed again.

Special tools and workshop equipment required

◆ Oil Drain Adapter - T40057-

– Remove the cap -arrow- from the oil filter housing.

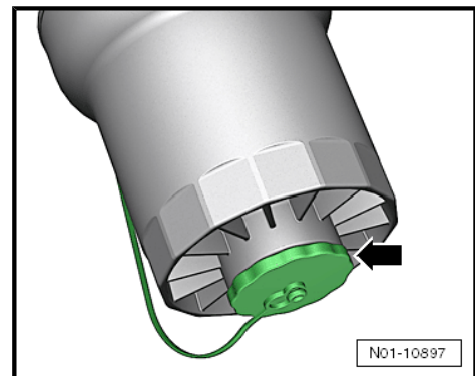



- Hold the Oil Drain Adapter - T40057- hose in a drip tray and install the Oil Drain Adapter - T40057- all the way onto the oil filter housing -2-.
- Allow the engine oil to drain.

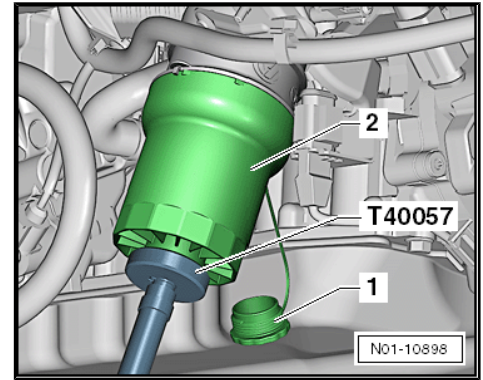



2 Description and Operation

⇒ "2.1 Oil Pan and Oil Pump Overview", page 102

⇒ "2.2 Oil Filter Adapter Overview", page 104

2.1 Oil Pan and Oil Pump Overview



Note

- ◆ If large quantities of metal particles or abraded material are detected during engine repairs, it may mean the crankshaft or rod bearings are damaged. To prevent further damage, perform the following steps after the repair:
- ◆ Clean the oil passages carefully.
- ◆ Replace the oil spray jets.
- ◆ Replace the engine oil cooler.
- ◆ Replace the oil filter element.

1 - Cylinder Block

2 - Oil Pump Timing Chain

- Beginning with MY 2008 the roller chain has been changed to a tooth chain.

3 - Bolt

- 20 Nm + an additional 90° (1/4) turn.
- Always replace.

4 - Bolt

- 25 Nm

5 - Oil Filter Adapter

- Overview. Refer to ⇒ "2.2 Oil Filter Adapter Overview", page 104 .

6 - Oil Pump Sprocket

- Removing and installing. Refer to one of the following:

Engine codes BGP and BGQ. Refer to ⇒ "4.3 Oil Pump", page 112 .

Engine codes CBTA and CBUA. Refer to ⇒ "4.4 Oil Pump", page 115 .

- Lettering points outward.
- With an anti-twist mechanism.

7 - Oil Pump

- Removing and installing. Refer to one of the following:

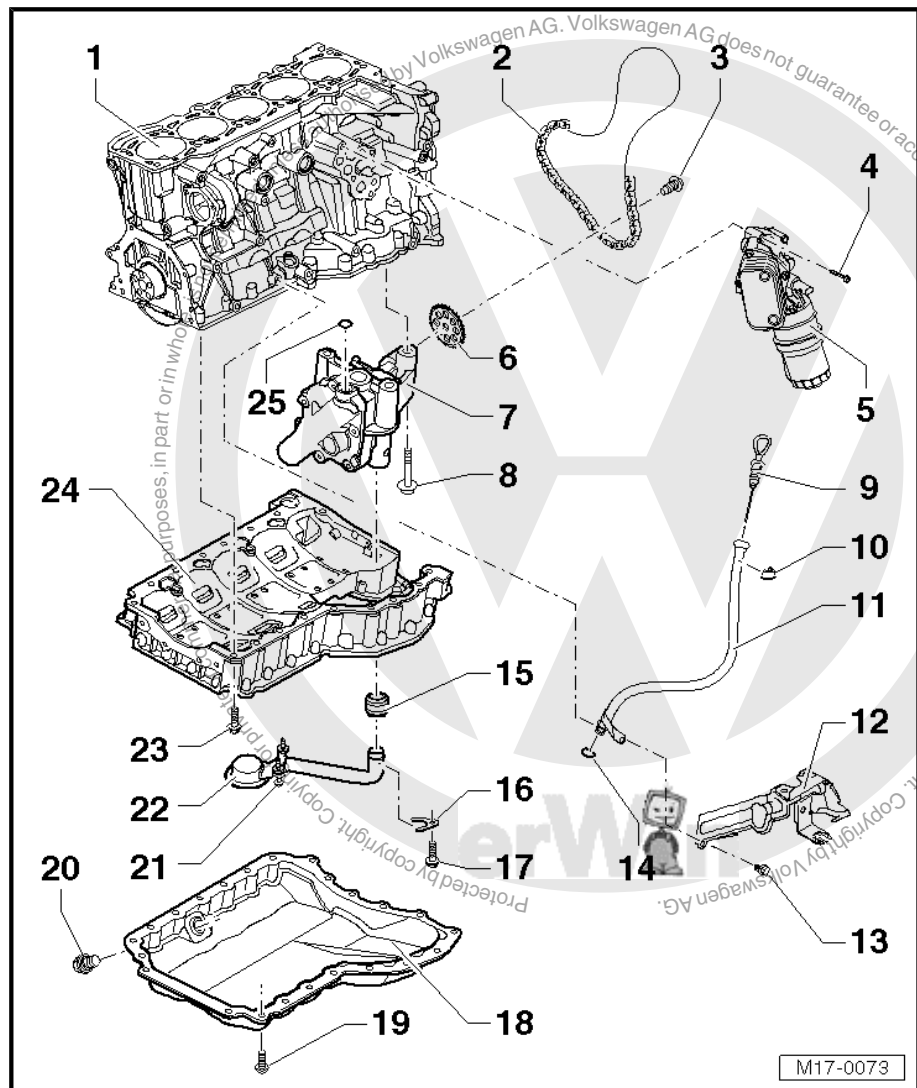

M17-0073



Engine codes BGP and BGQ. Refer to ⇒ [“4.3 Oil Pump”, page 112](#) .

Engine codes CBTA and CBUA. Refer to ⇒ [“4.4 Oil Pump”, page 115](#) .

8 - Bolt

- 25 Nm

9 - Oil Dipstick

- The oil level must not be above the MAX. mark!

10 - Retaining Ring

- Clipped in at the intake manifold.

11 - Guide Tube

12 - Intake Manifold Support

- Only for engines with a Secondary Air Injection (AIR) system.

13 - Bolt

- 25 Nm

14 - O-Ring

- Always replace.

15 - Seal

- Always replace.

16 - Bracket

17 - Bolt

- 10 Nm

18 - Lower Oil Pan

- Removing and installing. Refer to ⇒ [“4.1 Lower Oil Pan”, page 108](#) .

19 - Bolt

- 10 Nm

20 - Oil Pan Drain Plug

- 30 Nm
- Always replace.

21 - Coupling Element

- Bolt - 10 Nm

22 - Oil Intake Pipe

23 - Bolt

- 25 Nm

24 - Upper Oil Pan

- Removing and installing. Refer to ⇒ [“4.2 Upper Oil Pan”, page 109](#) .

25 - O-Ring

- Always replace.



2.2 Oil Filter Adapter Overview

1 - Bolt

- 25 Nm

2 - Oil Filter Adapter

- Removing:
 - Drain the coolant. Refer to [⇒ "1.1 Coolant, Draining and Filling", page 121](#) .
 - Remove the intake manifold. Refer to [⇒ "5.3 Intake Manifold", page 161](#) .
 - Unscrew connection for thermostat.
 - Disconnect the coolant hose from the thermostat housing.
 - Drain the oil filter housing. Refer to [⇒ "1.2 Oil Filter Housing, Draining", page 100](#) and remove it.
 - Loosen the intake manifold support, if necessary.
 - Remove the oil filter adapter bolts, the vent hose -item 6- remains connected.

3 - Gasket

- Always replace.

4 - Oil Pressure Switch - F1-

- 20 Nm
- 1.4 bar (20.30 psi), black connector.
- Checking. Refer to [⇒ "3.1 Oil Pressure and Oil Pressure Switch, Checking", page 106](#) .

5 - From the Intake Tube

- -3- refer to [⇒ "2.2 Engine Cover with Air Filter Overview", page 150](#) .

6 - Vent Hose

- Because of the 4 pin retainer, disconnect only when the oil filter is removed.

7 - Cap

8 - Oil Filter Housing

- 25 Nm
- Remove and install using the Oil Filter Wrench - 3417- .
- Draining. Refer to [⇒ "1.2 Oil Filter Housing, Draining", page 100](#) .

9 - Seal

- Always replace.
- Insert when lubricated.
- Installed position: Service flag upward.

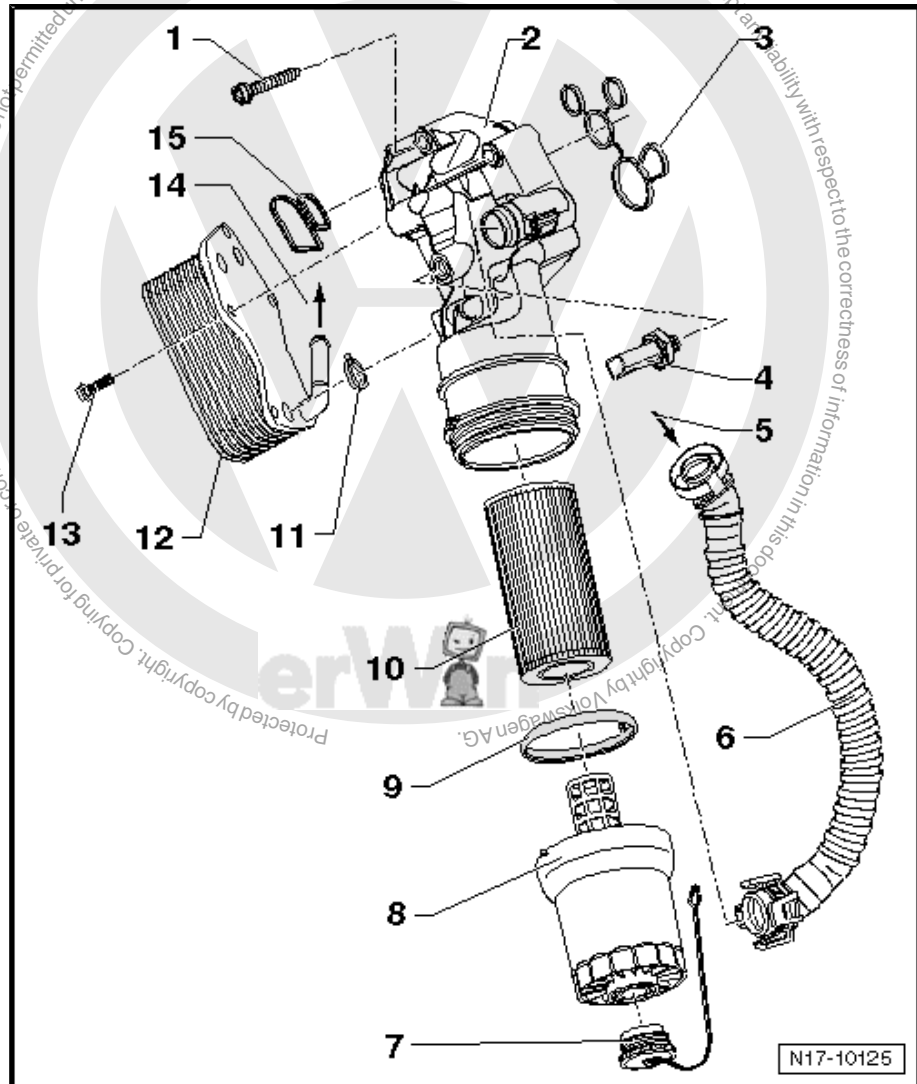



10 - Oil Filter Element

- Drain the oil filter housing before removing. Refer to ⇒ [“1.2 Oil Filter Housing, Draining”, page 100](#) .
- Replacing. Refer to “Engine Oil, Draining or Extracting, Changing Oil Filter and Filling Oil” Maintenance Procedures, Rep. Gr. 03, Maintenance Procedures.

11 - Gasket

- Always replace.

12 - Engine Oil Cooler

- See the note. Refer to ⇒ [“2.1 Oil Pan and Oil Pump Overview”, page 102](#) .
- Make sure there is enough space to the surrounding components.
- Coolant hose connection diagram. Refer to ⇒ [“2.1 Coolant Hose Connection Diagram”, page 124](#) .

13 - Bolt

- 25 Nm

14 - To the Thermostat Housing

15 - Gasket

- Always replace.





3 Diagnosis and Testing

⇒ **"3.1 Oil Pressure and Oil Pressure Switch, Checking",
page 106**

3.1 Oil Pressure and Oil Pressure Switch, Checking

Special tools and workshop equipment required

- ◆ Oil Pressure Gauge - VAG1342-
- ◆ Voltage Tester - VAG1527B-
- ◆ Connector Test Set - VAG1594C-
- ◆ Socket 24 mm and Jointed Extension - T40175-
- The engine oil level is OK
- The engine oil temperature at least 80 °C (176 °F) (the coolant fan must start up once).



Note

For the function test and servicing the optical and acoustic oil pressure indicator. Refer to the wiring diagrams and to "Function and Component Selection" in the vehicle diagnostic tester.



- Remove the Oil Pressure Switch - F1- and install it in the pressure gauge.
- Thread the oil pressure gauge into the oil filter adapter, in place of the oil pressure switch.
- Connect the brown wire on the gauge to ground (-).
- Connect the Voltage Tester - VAG1527B- using an adapter cable from the connector test set - VAG1594C- to battery positive (B+) and the oil pressure switch. The Light Emitting Diode (LED) must not light up.
- If the LED lights up, replace the oil pressure switch.

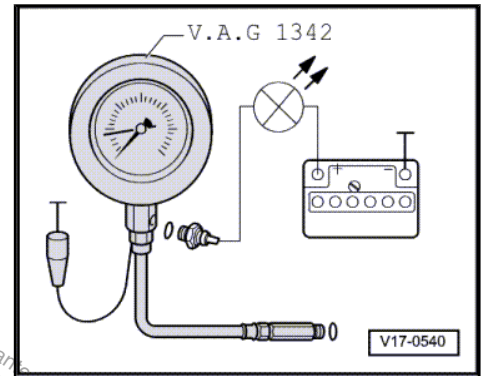

If the LED does not light up:

- Start the engine and increase the engine speed: The LED must illuminate at 1.2 to 1.6 bar (17.4 to 23.2 psi). Replace the oil pressure switch if it does not.
- Increase the engine speed further. At 2000 RPM and an oil temperature of 80 °C (176 °F), the oil pressure must be between 2.7 and 4.5 bar (39.16 to 65.26 psi).

At higher engine speeds the oil pressure must not exceed 7.0 bar (101.52 psi)

If the specification is not obtained:

- Check the screen in the oil intake pipe for contamination.



Note

Also, mechanical damage, for example, bearing damage can also be the cause of too low oil pressure.

If no malfunction can be found:

- Replace the oil pump. Refer to one of the following:

Engine codes BGP and BGQ. Refer to
 ⇒ ["4.3 Oil Pump", page 112](#) .

Engine codes CBTA and CBUA. Refer to
 ⇒ ["4.4 Oil Pump", page 115](#) .

If the specification is exceeded:

- Check the oil passages.
- If necessary, replace the oil filter adapter with pressure relief valve.



4 Removal and Installation

⇒ "4.1 Lower Oil Pan", page 108

⇒ "4.2 Upper Oil Pan", page 109

Engine Codes BGP and BGQ ⇒ "4.3 Oil Pump", page 112

Engine Codes CBTA and CBUA ⇒ "4.4 Oil Pump", page 115

4.1 Lower Oil Pan

Special tools and workshop equipment required

- ◆ Torque Wrench (5-50 Nm) - VAG1331-
- ◆ Hand Drill with Plastic Brush Attachment
- ◆ Protective Eyewear
- ◆ Silicone Sealant - D174003A2-

Removing

- Remove the noise insulation. Refer to ⇒ Body Exterior; Rep. Gr. 50 ; Description and Operation .
- Drain the engine oil.



Note

Observe disposal regulations!

- Remove the oil pan bolts.
- Press the lower oil pan at the tabs -arrows- on the upper oil pan. Be careful not to damage the sealing surfaces in the process.
- Replace the lower oil pan lower if damaged.

Installing



WARNING

To prevent injuries from shavings, wear protective goggles and protective clothing.

- Remove any sealant residue on the cylinder block and the upper oil pan using for example, a rotating plastic brush.



Caution

Make sure that no sealant residue enters the engine.

- Clean the sealing surfaces so they are completely free of any oil or grease.

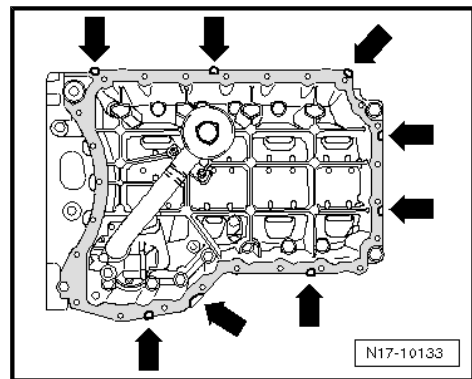



- Cut the sealant tube nozzle at the front mark (nozzle diameter: approximately 1 mm).

Note the shelf life date.

i Note

The lower oil pan must be installed within 5 minutes after application of the sealant.

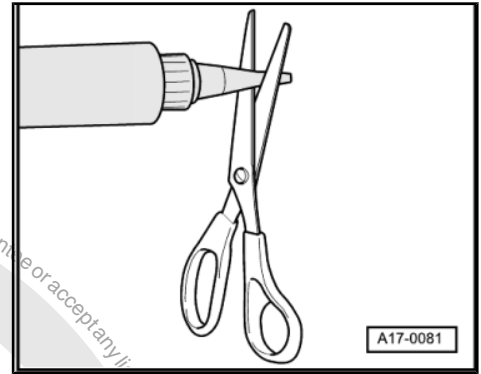

- With the engine removed, apply a sealant bead -A- to the clean sealing surface on the upper oil pan as illustrated.
- ◆ The sealant bead must be 1.5 to 2.0 mm thick.

i Note

- ◆ *With the engine installed, apply the sealant to the lower oil pan the same way.*
- ◆ *The sealant bead must be routed on the inside of the bolt holes.*

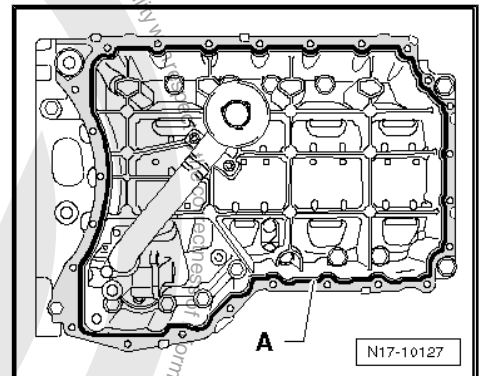

- Install all the bolts and tighten them in a diagonal sequence.

The rest of the installation follows the reverse of the removal procedure. Note the following:

- ◆ After installing the lower oil pan, the sealant must dry for approximately 30 minutes. Only after then may the engine oil be added.

Tightening Specifications

Component	Nm
Lower oil pan to upper oil pan	10

4.2 Upper Oil Pan

Special tools and workshop equipment required

- ◆ Adapter Plates - 2036/1-
- ◆ Torque Wrench (5-50 Nm) - VAG1331-
- ◆ Locking Pin - T10115-
- ◆ 3 M8 x 20 Bolts and 3 Washers
- ◆ Hand Drill with Plastic Brush Attachment
- ◆ Protective Eyewear
- ◆ Silicone Sealant - D174003A2-

Removing

- Remove the adjuster and sprocket from the camshafts. Refer to ⇒ ["3.3 Valve Timing, Adjusting", page 75](#) .
- Remove the sealing flange, transmission side. Refer to ⇒ ["5.9 Sealing Flange, Transmission Side", page 54](#) .



- Tension the chain tensioner -1- and secure it using the Locking Pin - T10115- .
- Remove the guide rail -2-.
- Remove the sealing flange, belt pulley side. Refer to => ["5.5 Sealing Flange, Belt Pulley Side"](#), page 49 .
- Remove the lower oil pan. Refer to => ["4.1 Lower Oil Pan"](#), page 108 .

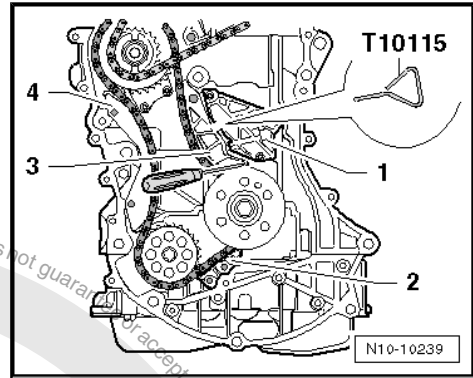

- Remove the bolts -2- and 4- and remove the oil intake pipe.
- Remove the bolts -1-.

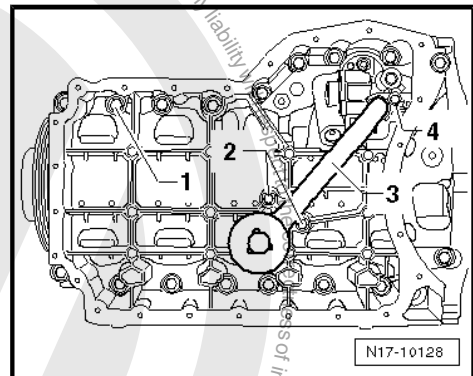

- Pry the upper oil pan from the cylinder block using a suitable screwdriver -A- at the areas shown.
- B - Crankshaft bearing cap 6
 C - Crankshaft bearing cap 1

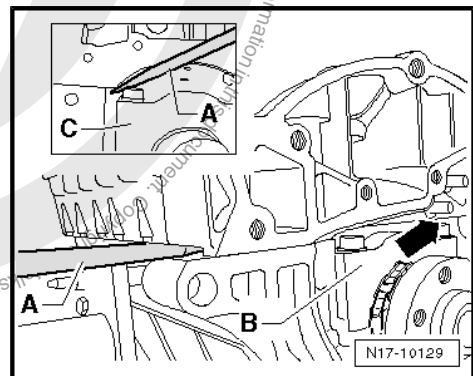

Installing



WARNING

To prevent injuries from shavings, wear protective goggles and protective clothing.

- Remove any sealant residue from the cylinder block using for example, a rotating plastic brush.



Caution

Make sure that no sealant residue enters the engine.

- Clean the sealing surfaces so they are completely free of any oil or grease.



- Cut the sealant tube nozzle at the front mark (nozzle diameter: approximately 1 mm).

Note the shelf life date.

i Note

The upper oil pan must be installed within 5 minutes after application of the sealant.

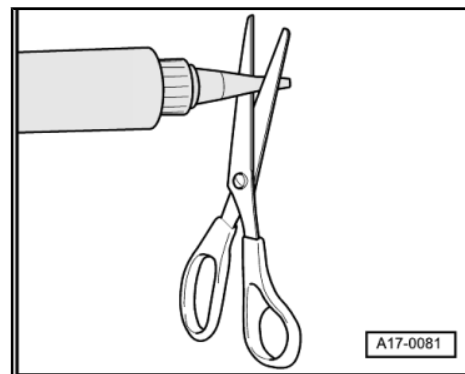

- Apply sealant beads -1, 2 and 3- to the clean sealing surfaces of the upper oil pan as shown.
- ◆ The sealant beads must be 1.5 to 2.0 mm thick.
- Position the upper oil pan on the cylinder block and align it on the transmission side.
- Install 2 bolts each, at the front and rear hand tight.

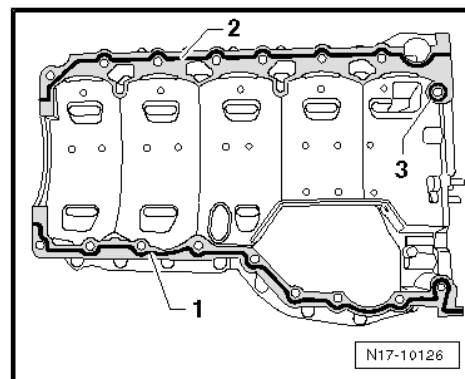

- Wipe off any excess sealant in the area of the -arrows-.
- Loosen the bolts again slightly.
- Install the Adapter Plates - 2036/1- onto the cylinder block as shown.
- Press the upper oil pan tightly against the Adapter Plates - 2036/1- and tighten the bolts hand tight.
- Install the remaining upper oil pan bolts and tighten them hand tight.

Make sure that upper oil pan makes contact with the Adapter Plates - 2036/1- .

- Tighten all the upper oil pan bolts in a diagonal sequence working from the inside toward the outside.
- Install a new seal -5- into the oil pump -6-.
- Secure the oil intake pipe -1- and the bracket -4- with the bolts -2 and 3-.

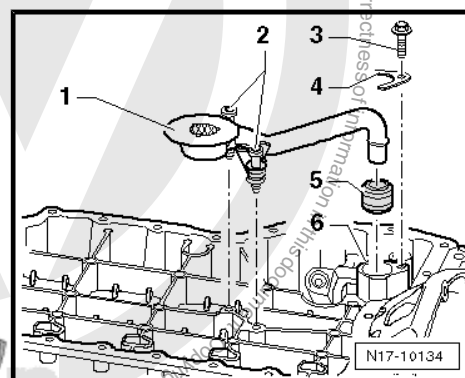
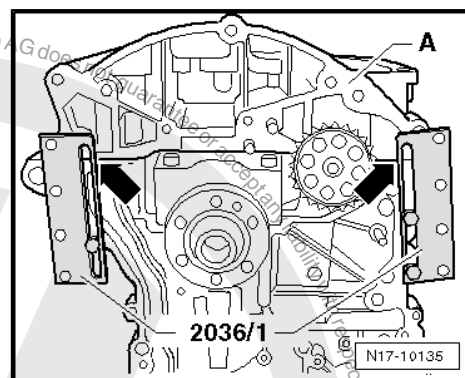



- Install the guide rail -2-, relieve tension on the chain tensioner -1- and pull out the Locking Pin - T10115- .
- Adjust the valve timing. Refer to [⇒ "3.3 Valve Timing, Adjusting", page 75](#) .

The rest of the installation follows the reverse of the removal procedure. Note the following:

- ◆ After installing the oil pan, allow the sealant to dry for approximately 30 minutes. Only after then may the engine oil be added.
- ◆ Remove the Locking Pin - T40069- from the rear of the cylinder block and install the locking bolt.
- ◆ Fill the coolant. Refer to [⇒ "1.1 Coolant, Draining and Filling", page 121](#) .

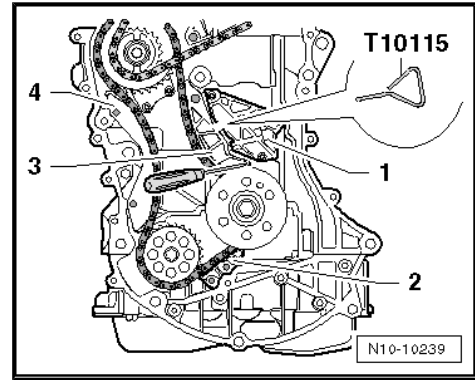

Tightening Specifications

Component	Nm
Upper oil pan to cylinder block	25
Oil intake pipe to oil pump	10
Oil intake tube to upper oil pan	10

4.3 Oil Pump

Special tools and workshop equipment required

- ◆ Torque Wrench (5-50 Nm) - VAG1331-
- ◆ Counterhold Tool - T10172-
- ◆ Oil Pump Align Plate - T03005-

Removing

- Remove the upper oil pan. Refer to [⇒ "4.2 Upper Oil Pan", page 109](#) .
- Tension the chain tensioner -1-, secure it using the Locking Pin - T10115- and remove the chain tensioner.

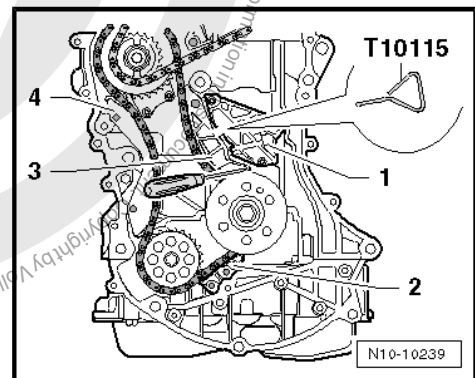

- Remove the sprocket bolt -1-.
- Hold the sprocket -2- in place using the Counterhold Tool - T10172- .
- Remove the sprocket from the oil pump and remove the oil pump.

Installing

- The crankshaft is secured

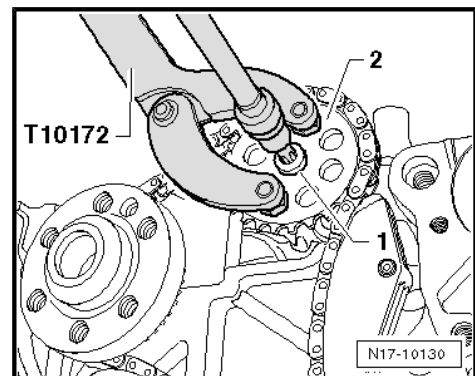



- Replace the O-ring -25-. Refer to [⇒ "2.1 Oil Pan and Oil Pump Overview", page 102](#) and tighten the oil pump to the cylinder block bolts hand tight.
- Position the sprocket on the oil pump with the writing facing outward. Secure it with a new bolt -1-. The drive chain is not installed yet.

Tightening specification: 20 Nm + an additional 90° (1/4) turn.

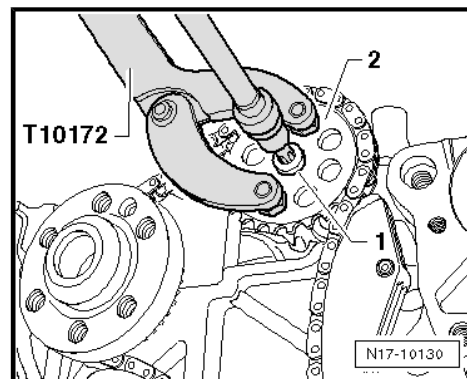

- Loosen the oil pump bolts -2 through 4-. The oil pump must be able to slide easily.
- Check the Oil Pump Align Plate - T03005- . If there are still protective shields on the magnets, remove them.
- Check that there are no shavings on the oil pump align plate magnets . The contact surfaces on the crankshaft, the align plate and the sprocket must be clean.

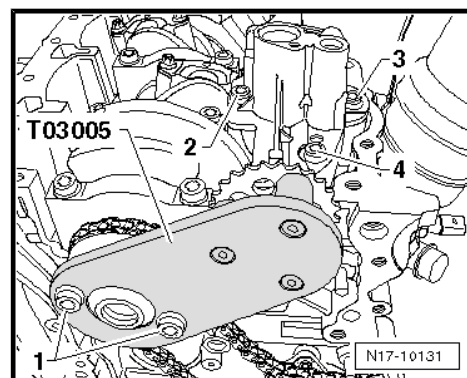

- Place the Oil Pump Align Plate - T03005- onto the crankshaft and secure it with 2 vibration damper bolts -1-.

Tightening specification: 30 Nm

The oil pump is activated by the magnets.

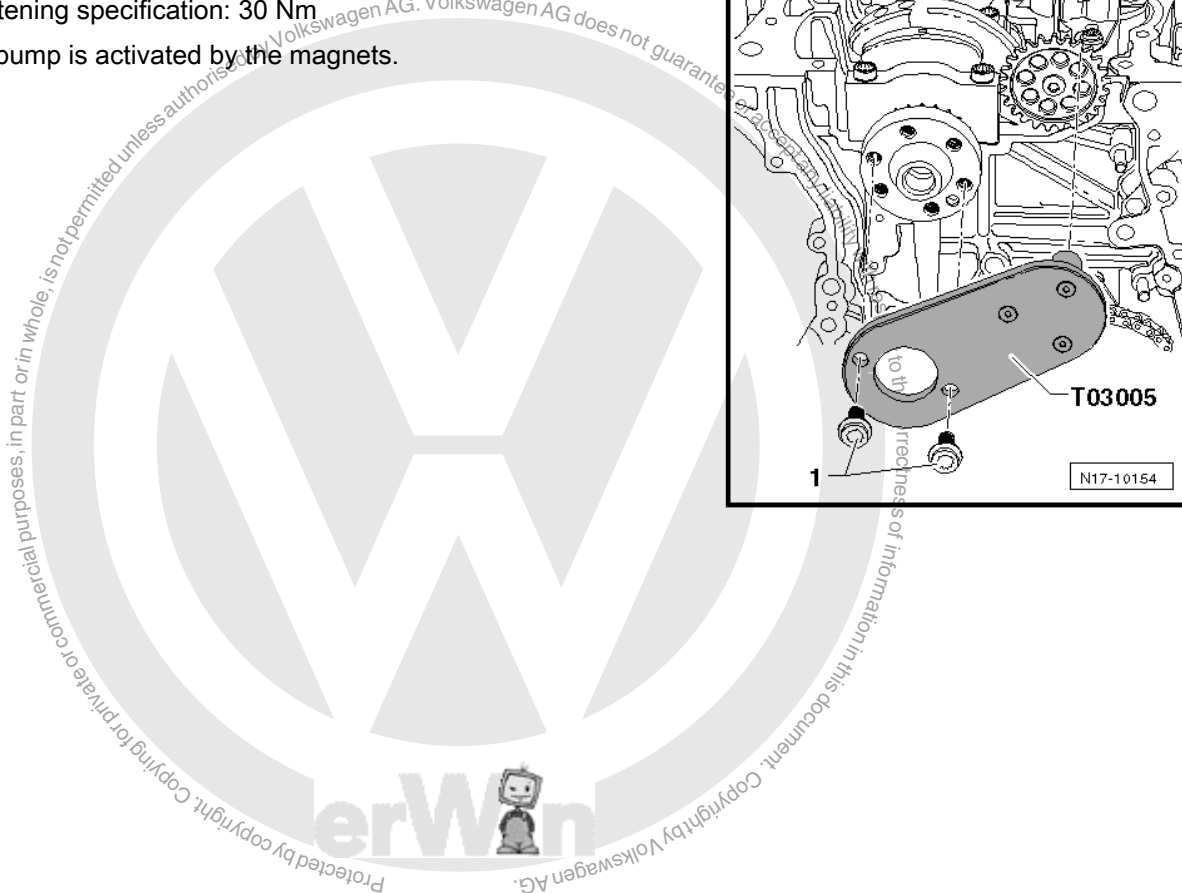
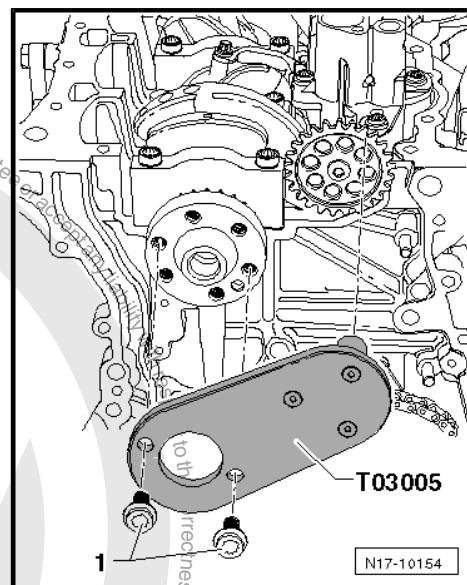



- Remove the Locking Pin - T40069- .

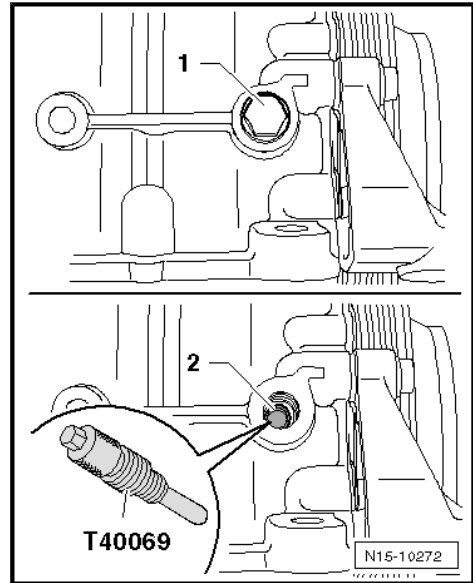

- Press the crankshaft in the axial bearing play toward the belt drive -arrow 1- and secure it with a -shim- as shown in the illustration.
- Press the oil pump lightly toward the chain drive -arrow 2-.



Note

This step is important in order to guarantee correct position of the sprockets to each other.

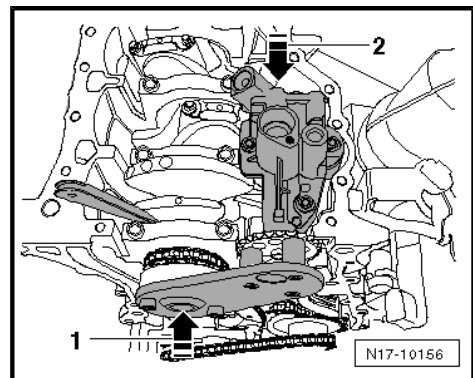

- In this condition, first tighten the bolts -2 and 3- and then tighten the bolt -4- to 25 Nm.
- Install the Locking Pin - T40069- again. The crankshaft must only be rotated slightly around the Top Dead Center (TDC) point for this. Otherwise there is a risk the valves will rest on the pistons.
- Remove the Oil Pump Align Plate - T03005- .
- If a new oil pump is installed, fill the oil pump with some engine oil via the intake passage and rotate the oil pump several times through.
- Place the chain onto the oil pump sprocket.
- Install the upper oil pan. Refer to ["4.2 Upper Oil Pan", page 109](#) .

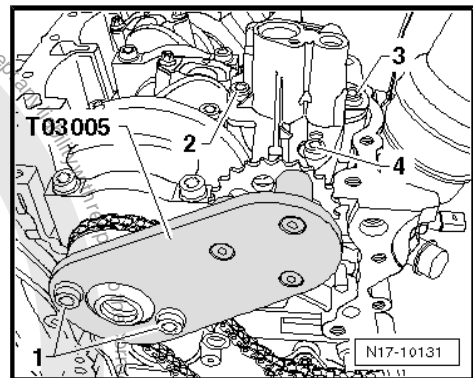



- Install the guide rail -2-, relieve tension on the chain tensioner -1- and pull out the Locking Pin - T10115- .

i Note

Make sure that the chain lies correctly in the guide rail -4- and in the tensioning rail -3-.

- Adjust the valve timing. Refer to ["3.3 Valve Timing, Adjusting", page 75](#) .

The rest of the installation follows the reverse of the removal procedure. Note the following:

- ◆ Remove the Locking Pin - T40069- from the rear of the cylinder block and install the locking bolt (30 Nm).
- ◆ Fill the coolant. Refer to ["1.1 Coolant, Draining and Filling", page 121](#) .

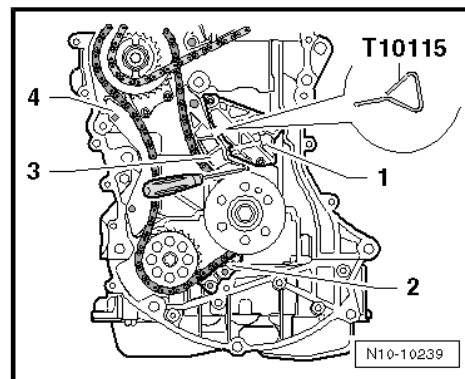

4.4 Oil Pump

i Note

In MY 2008, the oil pump timing chain was changed from a roller chain to a toothed chain. The gears are now wider and the Oil Pump Shim - T03005/1- must also be used when securing the oil pump.

Special tools and workshop equipment required

- ◆ Torque Wrench (5-50 Nm) - VAG1331-
- ◆ Counterhold Tool - T10172-
- ◆ Oil Pump Align Plate - T03005-
- ◆ Oil Pump Shim - T03005/1-

Removing

- Remove the upper oil pan. Refer to ["4.2 Upper Oil Pan", page 109](#) .
- Tension the chain tensioner -1-, secure it using the Locking Pin - T10115- and remove the chain tensioner.

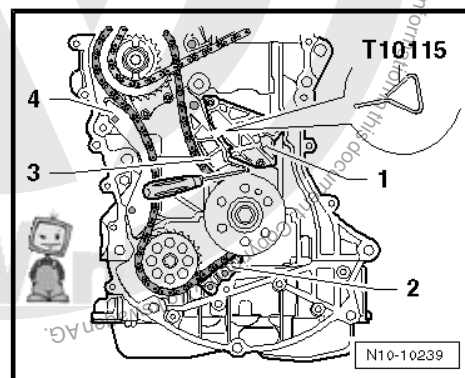



- Remove the sprocket bolt -1-.
- Hold the sprocket -2- in place using the Counterhold Tool - T10172- .
- Remove the sprocket from the oil pump and remove the oil pump.

Installing

- The crankshaft is secured
- Replace the O-ring item -25-. Refer to ["2.1 Oil Pan and Oil Pump Overview", page 102](#) and tighten the oil pump to cylinder block bolts hand tight.
- Position the sprocket onto the oil pump with the writing facing outward. Secure it with a new bolt -1-. The chain is not installed yet.

Tightening specification: 20 Nm + an additional 90° (1/4) turn.

- Loosen the oil pump bolts -2 through 4-. The oil pump must be able to slide easily.
- Check the Oil Pump Align Plate - T03005- . If there are still protective shields on the magnets, remove them.
- Check that there are no shavings on the oil pump align plate magnets. The contact surfaces on the crankshaft, the oil pump align plate and the sprocket must be clean.

- Place the Oil Pump Shim - T03005/1- and the Oil Pump Align Plate - T03005- on the crankshaft and secure both with the 2 vibration damper bolts -1-.

Tightening specification: 30 Nm

The oil pump is activated by the magnets.

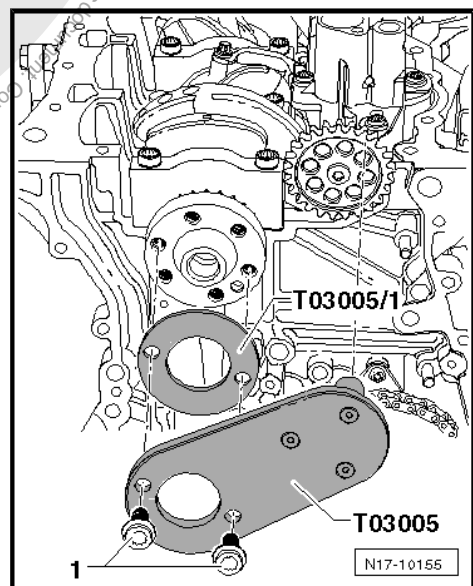
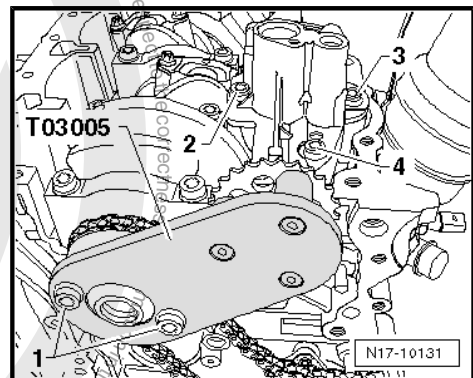
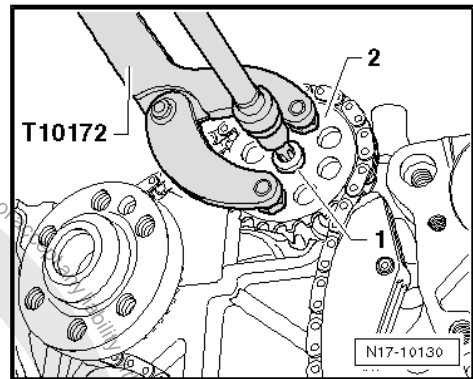
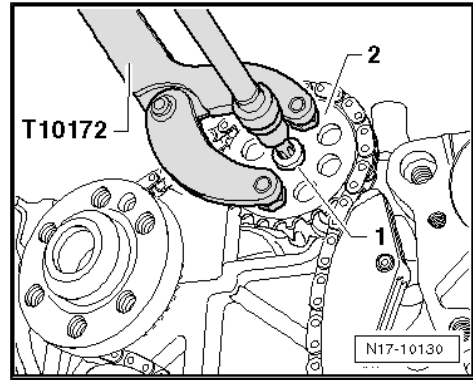



- Remove the Locking Pin - T40069- .

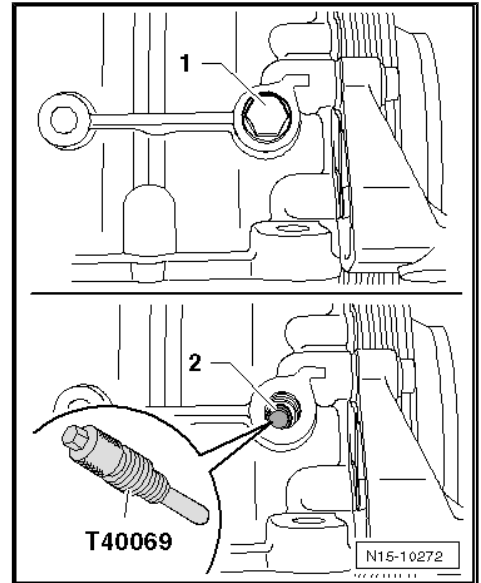

- Press the crankshaft in the axial bearing play toward the belt drive -arrow 1- and secure it with a -shim- as shown in the illustration.
- Press the oil pump lightly toward the chain drive -arrow 2-.

i Note

This step is important in order to guarantee correct position of the sprockets to each other.

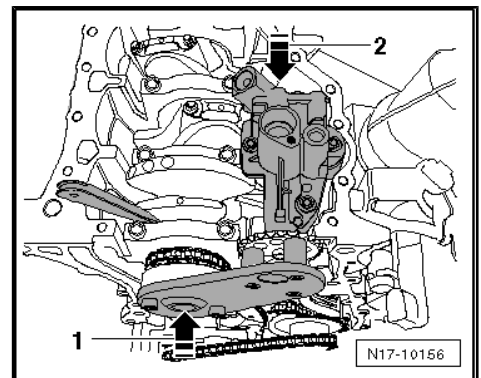

- In this condition, first tighten the bolts -2 and 3- and then tighten the bolt -4- to 25 Nm.
- Install the Locking Pin - T40069- again. The crankshaft must only be rotated slightly around the Top Dead Center (TDC) point for this. Otherwise there is a risk the valves will rest on the pistons.
- Remove the Oil Pump Align Plate - T03005- and the Oil Pump Shim - T03005/1- .
- If a new oil pump is installed, fill the oil pump with some engine oil via the intake passage and rotate the oil pump several times through.
- Place the chain onto the oil pump sprocket.
- Install the upper oil pan. Refer to ["4.2 Upper Oil Pan", page 109](#) .

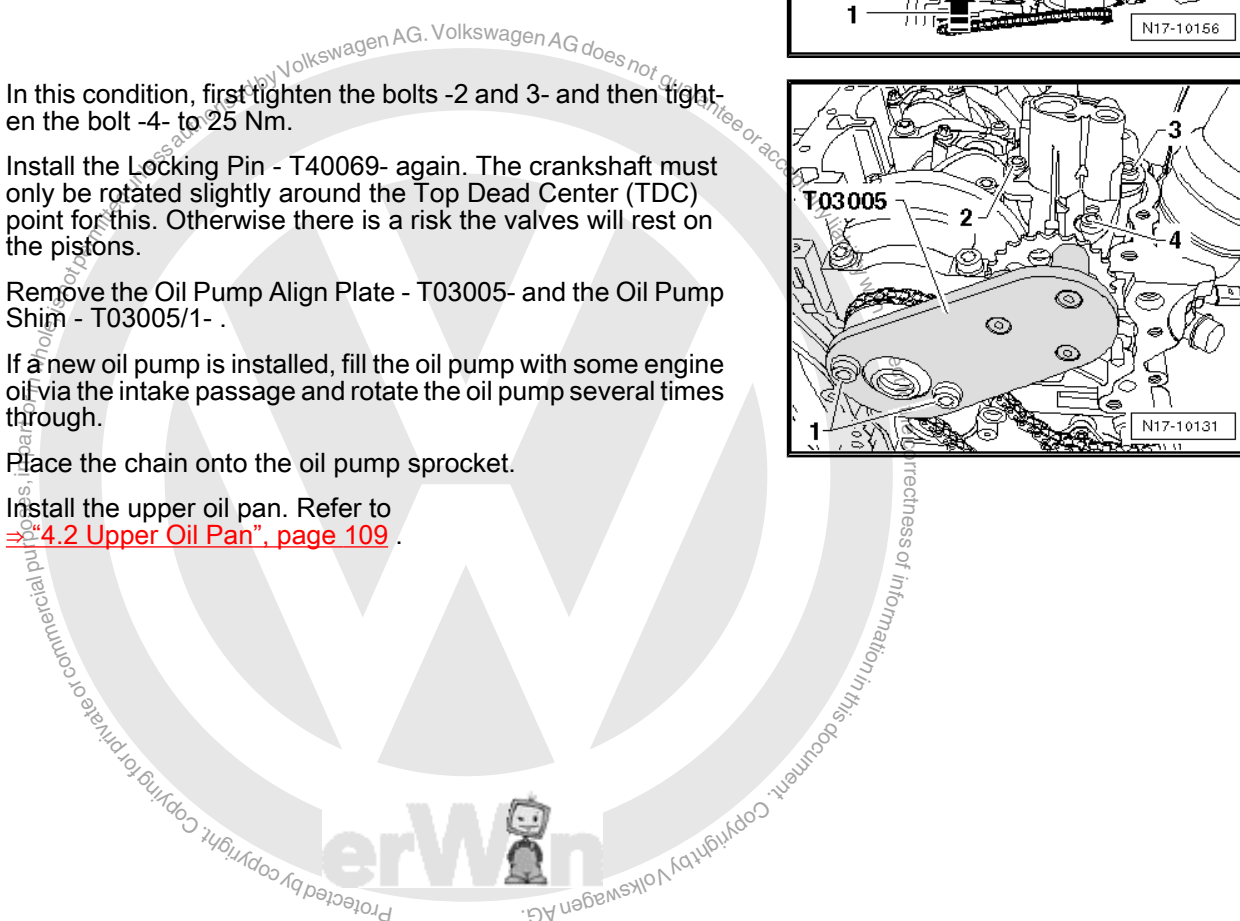
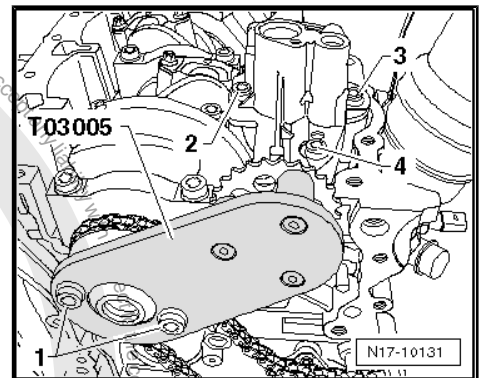



- Install the guide rail -2-, relieve the tension on the chain tensioner -1- and pull out the Locking Pin - T10115- .



Note

Make sure that the chain lies correctly in the guide rail -4- and in the tensioning rail -3-.

- Adjust the valve timing. Refer to ["3.3 Valve Timing, Adjusting", page 75](#) .

The rest of the installation follows the reverse of the removal procedure. Note the following:

- ◆ Remove the Locking Pin - T40069- from the rear of the cylinder block and install the locking bolt (30 Nm).
- ◆ Fill the coolant. Refer to ["1.1 Coolant, Draining and Filling", page 121](#) .

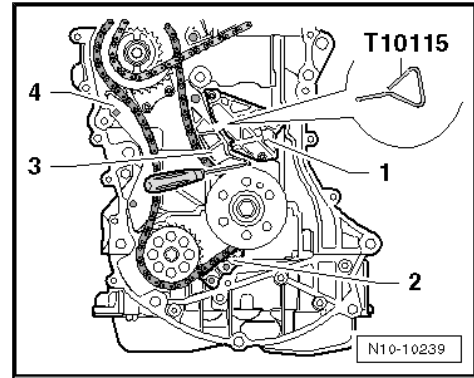



5 Special Tools

Special tools and workshop equipment required

- ◆ Counterhold Tool - T10172-
- ◆ Oil Pump Align Plate - T03005-
- ◆ Oil Pump Shim - T03005/1-
- ◆ Oil Drain Adapter - T40057-

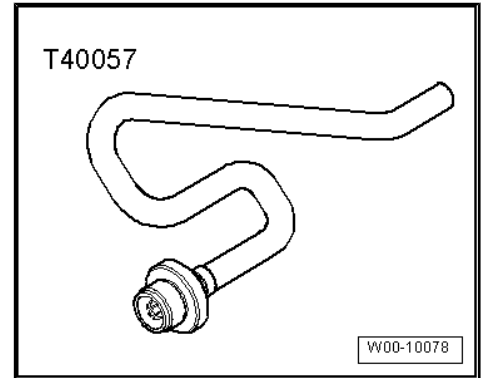

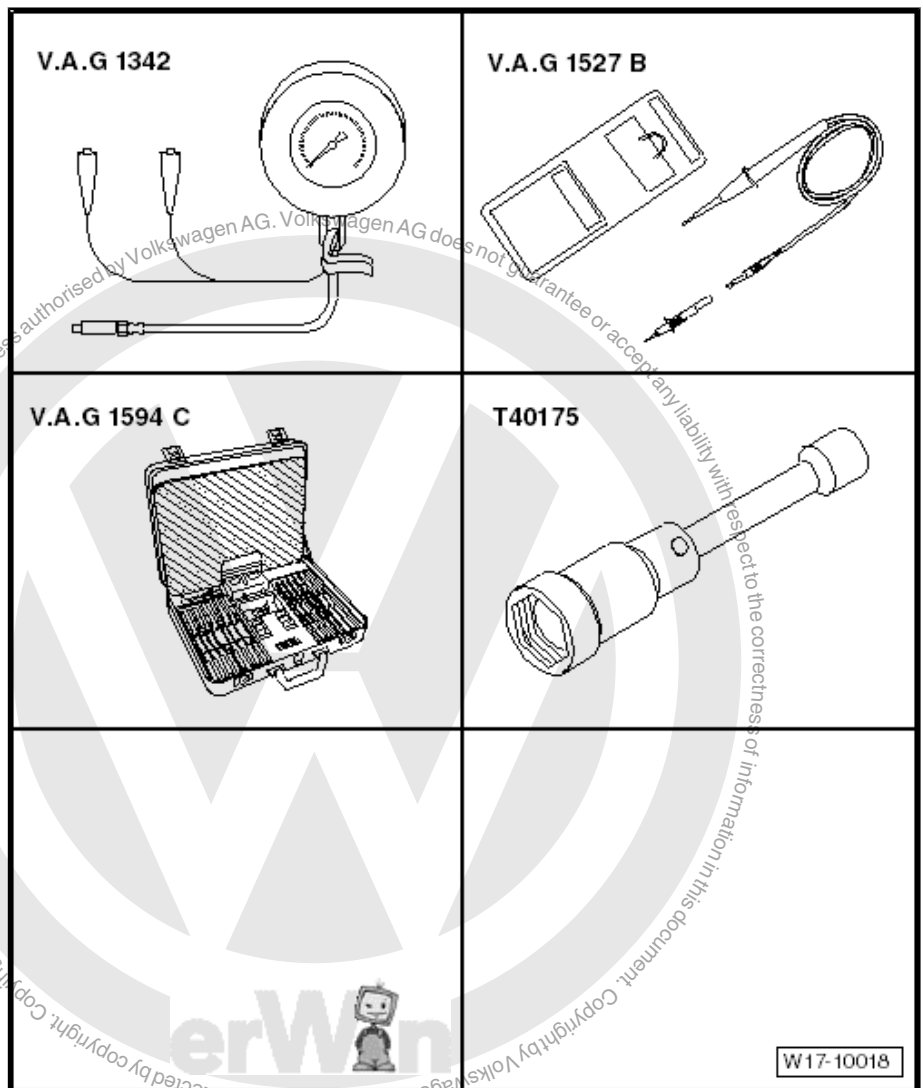

- ◆ Oil Pressure Gauge - VAG1342-
- ◆ Voltage Tester - VAG1527B-
- ◆ Connector Test Set - VAG1594C-
- ◆ Socket 24 mm and Jointed Extension - T40175-



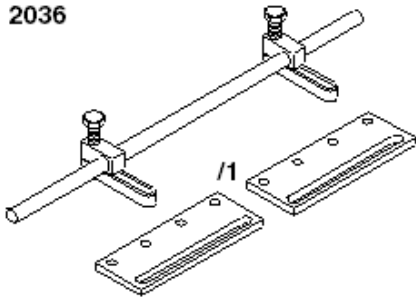

- ◆ Adapter Plates - 2036/1-
- ◆ Torque Wrench (5-50 Nm) - VAG1331-
- ◆ Locking Pin - T10115-

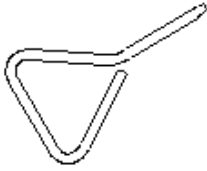
<p>2036</p>  <p>Diagram showing two adapter plates, one labeled '2036' and the other '2036/1', along with a bolt and nut assembly.</p>	<p>V.A.G 1331</p>  <p>Diagram of a torque wrench.</p>
<p>T10115</p>  <p>Diagram of a locking pin.</p>	
	<p>W17-10012</p>

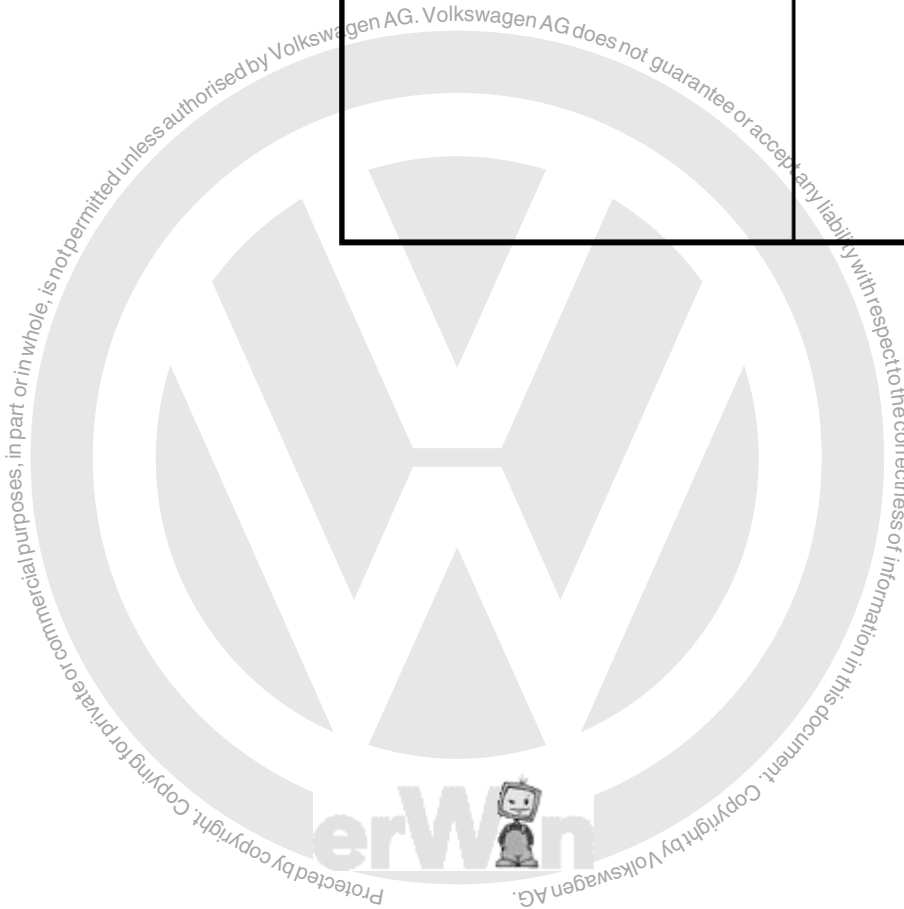



19 – Cooling System

1 General Information

⇒ **“1.1 Coolant, Draining and Filling”, page 121**

1.1 Coolant, Draining and Filling

Special tools and workshop equipment required

- ◆ Adapter - VAG1274/8-
- ◆ Shop Crane - Drip Tray - VAS6208-
- ◆ Hose Clip Pliers - VAS6362-
- ◆ Cooling System Charge Unit - VAS6096-
- ◆ Refractometer - T10007A-

Draining



Note

Follow disposal regulations.



WARNING

Hot steam may escape when opening the expansion tank cap. Wear protective goggles and protective clothing to prevent damage to eyes and scalding. Cover the cap with a cloth and open very carefully.

- Open the cap on the coolant expansion tank.
- Remove the noise insulation. Refer to ⇒ Body Exterior; Rep. Gr. 50 ; Description and Operation .
- Place the Drip Tray for VAS6100 - VAS6208- below.
- Open the spring clamp -1- and remove the coolant hose -2-.



Note

If the quick acting coupling on the lower radiator connection is pulled off, a large amount of coolant flows onto the bumper.

Filling



Caution

Only mix distilled water with coolant additives. Using distilled water provides optimum corrosion protection.

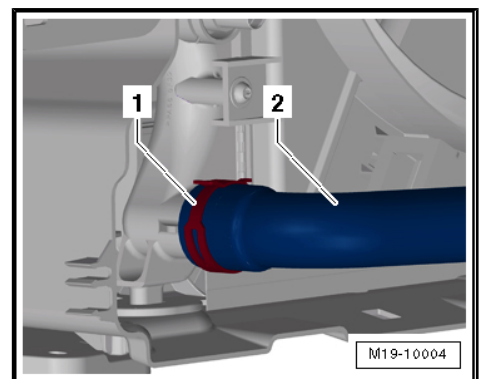



Note

- ◆ *The water portion of the coolant influences the effectiveness of the coolant. Based on the contents, the country or even the region specific quality can be different. Use distilled water. For this reason, we recommend using distilled water when adding coolant or filling coolant for the first time.*
- ◆ *Use only coolant additives listed in the Parts Catalog. Other coolant additives may above all reduce the corrosion protection effect significantly. The damage resulting from this may lead to loss of coolant and consequently to severe engine damage.*
- ◆ *Coolant with the correct mixture ratio prevents freezing and corrosion damage and calcium deposits. The boiling point will be raised. The cooling system must be filled with coolant additive year-round.*
- ◆ *Because of its high boiling point, the coolant contributes to engine reliability under heavy loads, particularly in countries with tropical climates.*
- ◆ *The Refractometer - T10007A- MUST be used to determine the freeze protection value.*
- ◆ *Protection against frost must be assured down to minimum -25 °C (-13 °F) (in arctic climatic countries down to approximately -36 °C (-32.8 °F)). When stronger freeze protection is needed due to the climate, the freeze protection may be increased. But only down to -48 °C (-54 °F), otherwise the effectiveness of the coolant decreases.*
- ◆ *The coolant concentration must not be reduced by adding water even in warmer seasons and in warmer countries. The frost protection must be at least -25 °C (-13 °F).*
- ◆ *Read the freeze protection value on the scale for the coolant additive that has been added.*
- ◆ *The temperature on the Refractometer - T10007A- corresponds to the »freezing point«. At this temperature, ice crystals may begin to form in the coolant.*
- ◆ *Do not reuse used coolant.*
- ◆ *Only use water/coolant additive to lubricate the coolant hoses.*

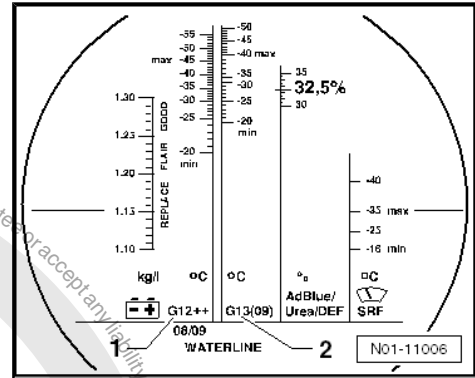

Recommended mixture ratios:

Frost Protection to	Anti-Freeze	Coolant Additive ¹⁾	Water ¹⁾
-25 °C	40 %	3.6L	5.4L
-35 °C	50 %	4.5L	4.5L

- ◆ ¹ The quantity of coolant can vary depending upon the vehicle equipment.



- Connect the coolant hose -2- to the radiator and secure it with the spring clamp -1-.
- Install the noise insulation. Refer to ⇒ Body Exterior; Rep. Gr. 50 ; Description and Operation .

Filling Using the Cooling System Charge Unit - VAS6096-

- Install the Adapter - VAG1274/8- onto the expansion tank.
- Fill the coolant circuit using the Cooling System Charge Unit - VAS 6096- . Refer to operating instructions for the cooling system charge unit.

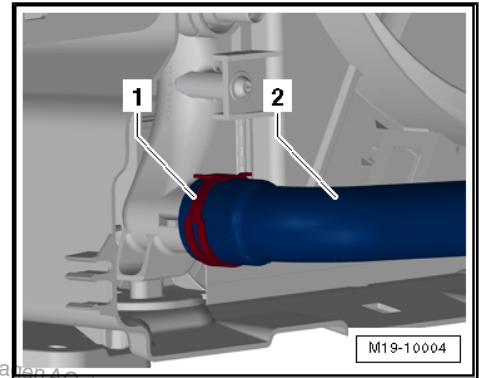

Filling Without Using the Cooling System Charge Unit - VAS 6096-

- Slowly fill the expansion tank up to the top mark in the shaded area -arrow-.
- Install the coolant expansion tank cap.
- Turn off the heater and Air Conditioning (A/C).
- Start the engine and maintain an engine speed of about 2000 RPM for approximately 3 minutes.
- Let the engine run until the fan starts up.

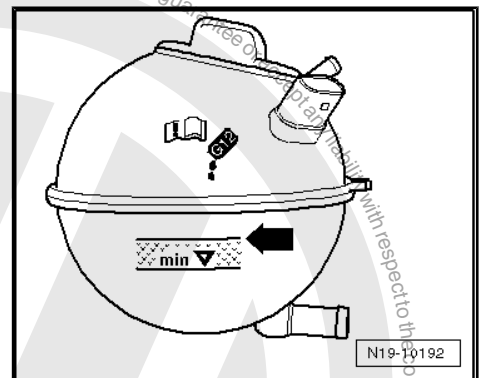

WARNING

Hot steam may escape when opening the expansion tank cap. Wear protective goggles and protective clothing to prevent damage to eyes and scalding. Cover the cap with a cloth and open very carefully.

- Check the coolant level and fill as necessary.
- ◆ With the engine at operating temperature, the coolant level must align with the top mark of the hatched area.
- ◆ When the engine is cold, the coolant level should be in the middle of the shaded area.

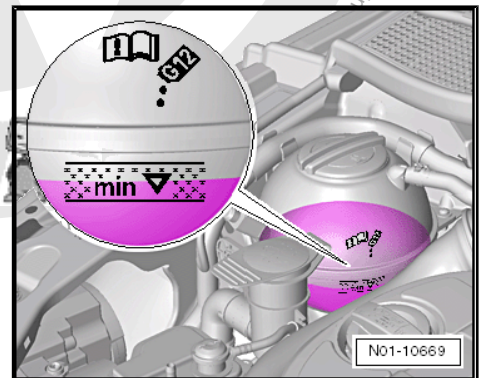



2 Description and Operation

⇒ "2.1 Coolant Hose Connection Diagram", page 124

⇒ "2.2 Coolant Pump and Thermostat Overview", page 125

⇒ "2.3 Radiator and Fan Overview", page 130

2.1 Coolant Hose Connection Diagram

1 - Radiator

- ❑ Removing and installing. Refer to ⇒ "4.4 Radiator", page 139 .
- ❑ Replace the coolant after replacing.

2 - Coolant Pipe

3 - Intake Manifold

4 - Coolant Pump and Coolant Thermostat

- ❑ Coolant pump removing and installing. Refer to ⇒ "4.2 Coolant Pump", page 135 .
- ❑ Thermostat removing and installing. Refer to ⇒ "4.1 Coolant Thermostat", page 134 .
- ❑ Checking the coolant thermostat, see item -17-. Refer to Part 1 of the ⇒ "2.2 Coolant Pump and Thermostat Overview", page 125 .

5 - Front Coolant Pipe

- ❑ Secured to the accessory bracket.

6 - Right Coolant Pipe

- ❑ Secured to the engine mount.

7 - Expansion Tank

- ❑ With a cap.
- ❑ Checking the pressure relief valve in the cap. Refer to ⇒ page 132 .

8 - Rear Coolant Pipe

9 - Cylinder Head/Cylinder Block

- ❑ Replace the coolant after replacing.

10 - Coolant Flange

11 - Quick-Release Coupling

- ❑ Lower connection.

12 - Heater Core

- ❑ Replace the coolant after replacing.

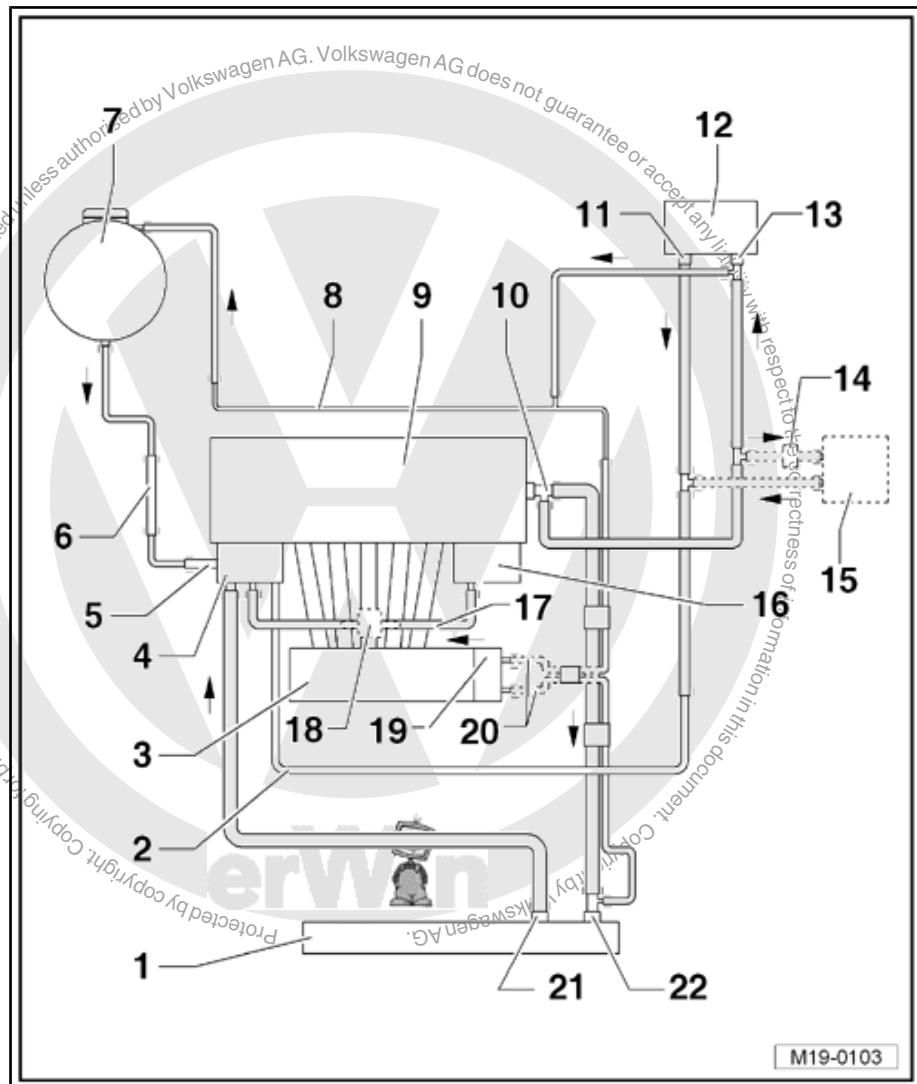

M19-0103



13 - Quick-Release Coupling

- Upper connection.

14 - Bypass Thermostat

- Only for vehicles with a automatic transmission.
- Overview. Refer to ⇒ [Fig. "“Bypass Thermostat Overview””](#) , page 129 .
- Checking. Refer to ⇒ [page 129](#) .

15 - Automatic Transmission Fluid Cooler

- Only for vehicles with a automatic transmission.

16 - Engine Oil Cooler

17 - Coolant Hose

2 versions:

- Without a engine pre-warmer
- With a engine pre-warmer

18 - Pre-Warmer

- Only on vehicles with a engine pre-warmer.

19 - Throttle Valve Control Module - J338-

- Connection only for a coolant heated throttle valve control module.

20 - Coolant Hoses

- Only for a throttle valve control module heated by coolant.

21 - Quick-Release Coupling

- Upper connection.

22 - Quick-Release Coupling

- Lower connection.

2.2 Coolant Pump and Thermostat Overview



Caution

When doing any repair work, especially in the engine compartment, pay attention to the following due to clearance issues:

- ◆ *Route all lines and wires in their original locations.*
- ◆ *Make sure there is enough clearance to moving or hot components to prevent damage to the lines.*



Note

- ◆ *When the engine is warm the cooling system is under pressure. If necessary release the pressure before beginning any repair work.*
- ◆ *Secure all hose connections with clamps, allocation. Refer to the Parts Catalog.*
- ◆ *The Hose Clip Pliers - VAG1921- or -VAS6362- are recommended for installing spring clamps.*
- ◆ *Always replace gaskets and seals.*
- ◆ *The arrows on coolant pipes and coolant hoses must line up across from each other.*

Part 1: Belt Pulley Side

Part 2: transmission side. Refer to ⇒ [page 127](#) .

- 1 - Cylinder Block
- 2 - Engine Oil Cooler
- 3 - Bolt
 - 25 Nm
- 4 - Bolt/Nut
 - 10 Nm
- 5 - To the Heater Core Lower Connection
- 6 - Retaining Clip
- 7 - O-Ring
 - Always replace.
- 8 - Front Coolant Pipe
- 9 - Connecting Hose
- 10 - O-Ring
 - Always replace.
- 11 - Coolant Pipe
- 12 - Connecting Hose
- 13 - Cover
- 14 - To the Radiator Lower Connection
- 15 - Bolt
 - 5 Nm
- 16 - O-Ring
 - Always replace.
- 17 - Coolant Thermostat
 - Removing and installing. Refer to

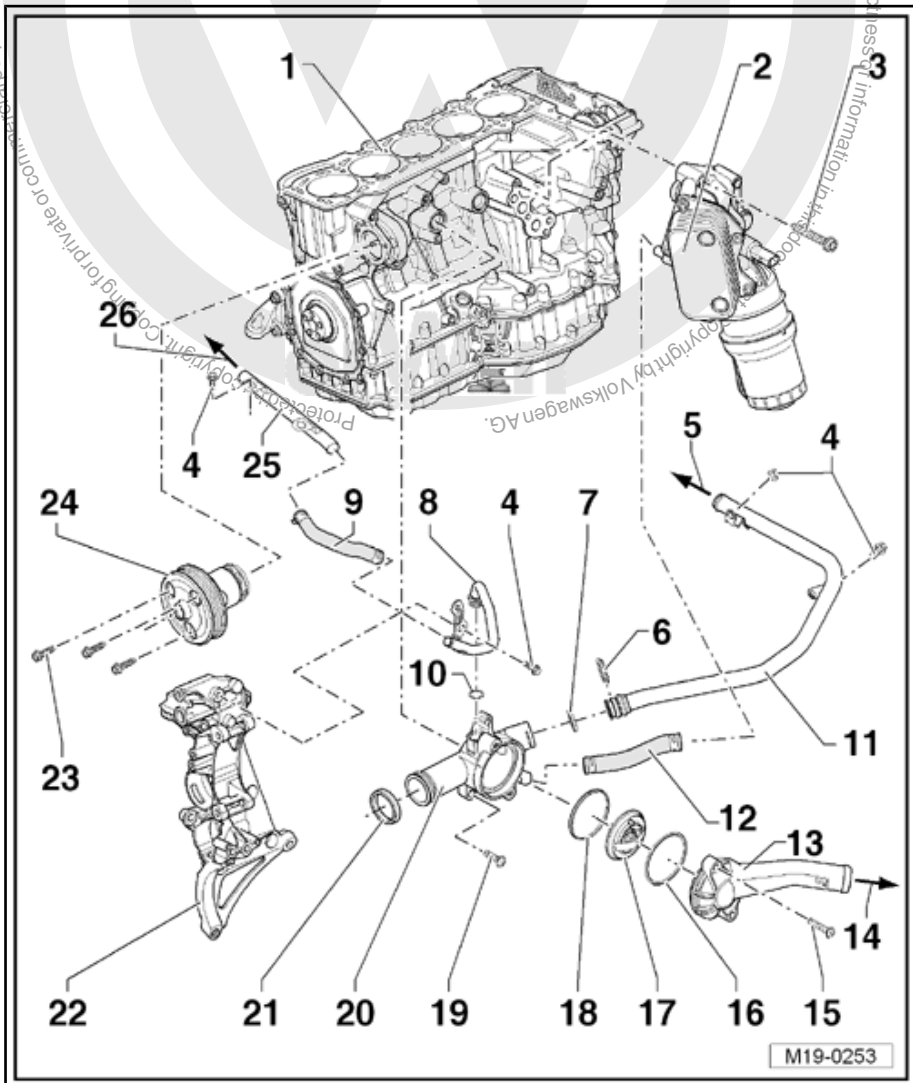

⇒ ["4.1 Coolant Thermostat", page 134](#) .

- Note the installed position: the valve must be at the top.
- Checking (coolant thermostat installed): Refer to the "Function and Component Selection" in the vehicle diagnostic tester.
- Checking (coolant thermostat removed):



Heat the thermostat in water.

Starts to open: approximately 87 °C (188.6 °F)
Opening ends: approximately 102 °C (215.6 °F)
Open distance: at least 7 mm

18 - Seal

- Always replace.

19 - Bolt

- 25 Nm

20 - Coolant Thermostat Housing

21 - Seal

- Always replace.

22 - Accessory Bracket

23 - Bolt

- 10 Nm

24 - Coolant Pump

- With an integrated silicone seal for sealing to the cylinder block.
- Removing and installing. Refer to ⇒ ["4.2 Coolant Pump", page 135](#) .

25 - Right Coolant Pipe

- Secured to the engine mount.

26 - To the Expansion Tank Lower Connection

Part 2: Transmission Side





1 - Coolant Connection

- Pressed in the cylinder head.
- Clean before installing the coolant flange -17-
- If necessary, remove any coolant deposits with a brass wire brush or with a fine sandpaper (minimum 100 grit).
- If the pipe connection is worn, replace it using Liquid Locking Fluid - D 000 600 A2- .

2 - Thrust Ring

3 - Seal

- Replace after removing the coolant flange -17-.

4 - To the Expansion Tank Upper Connection

5 - Rear Coolant Pipe

6 - Bolt/Nut

- 10 Nm

7 - Heat Shield

8 - To the Heater Core Upper Connection

9 - Supply Hose

10 - Bypass Thermostat

- Only for vehicles with a automatic transmission.
- Overview. Refer to [⇒ Fig. "Bypass Thermostat Overview"](#) , page 129 .
- Checking. Refer to [⇒ page 129](#) .

11 - To the Automatic Transmission Fluid Cooler

- Only for vehicles with a automatic transmission.

12 - To the Heater Core Lower Connection

13 - From the Automatic Transmission Fluid Cooler

- Only for vehicles with a automatic transmission.

14 - Return Hose

15 - Coolant Pipe

- Bolted to the coolant flange -17-

16 - To the Coolant Thermostat Housing

17 - Flange

18 - Supply Hose

19 - To the Radiator Upper Connection

20 - Coolant Hoses

- Only for a throttle valve control module heated by coolant.

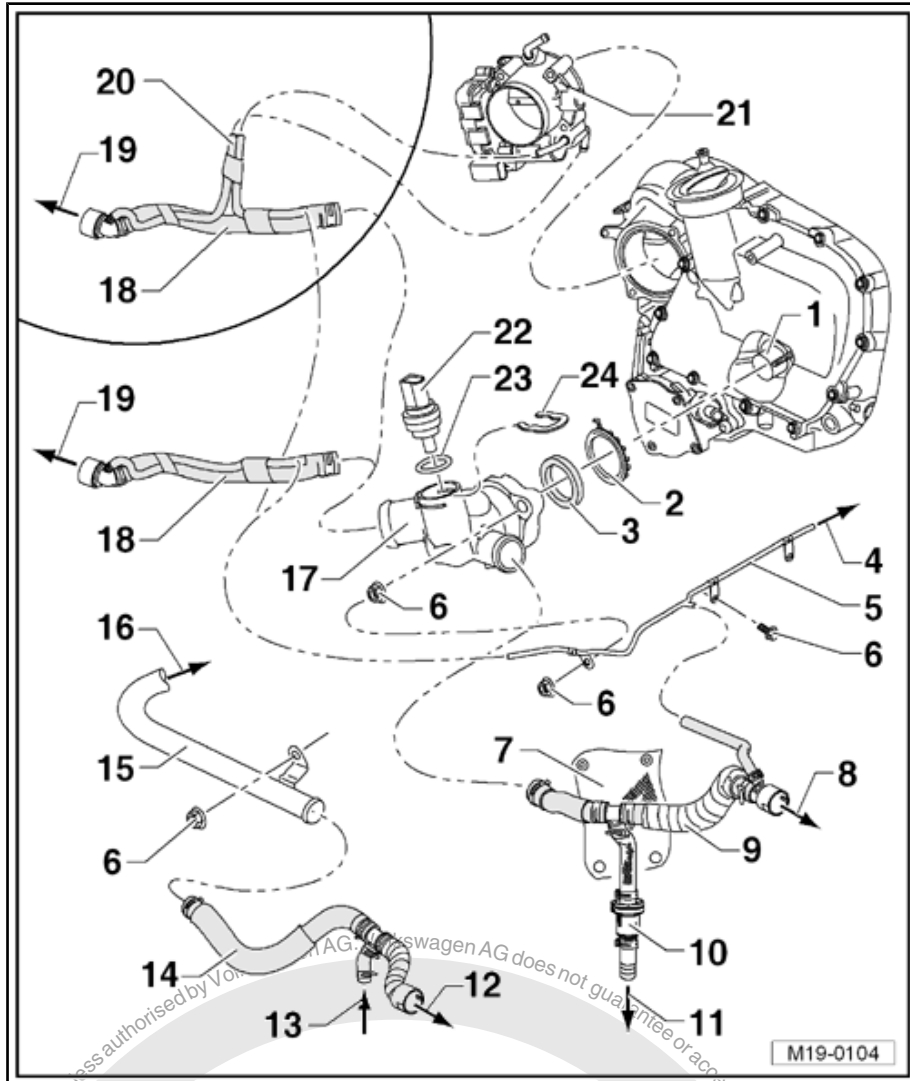



21 - Throttle Valve Control Module - J338-

22 - Engine Coolant Temperature Sensor - G62-

23 - O-Ring

- Always replace.

24 - Retaining Clip

Bypass Thermostat Overview

- 1 - Spring bracket
- 2 - Lower part of housing
- Note the installed position: The arrow points toward the automatic transmission fluid cooler
- 3 - Operating element
- 4 - Spring
- 5 - O-ring
- 6 - Upper part of housing

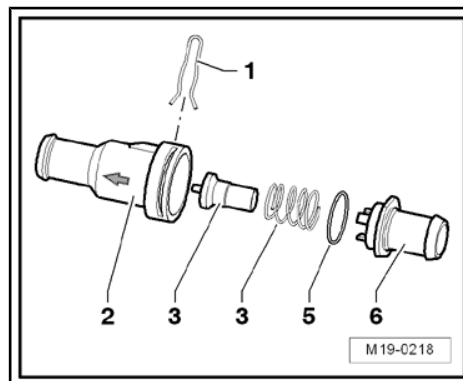

Checking the Bypass Thermostat:

- Remove the operating element -3- and heat in a hot water bath.

Starts to open: approximately 75 °C (167 °F)

Stops at: approximately 85 °C (185 °F)

Opening lift: approximately 5 mm





2.3 Radiator and Fan Overview

1 - Upper Coolant Hose

- From the coolant thermostat housing to the cylinder head.

2 - O-Ring

- Replace if damaged.

3 - Radiator

- Removing and installing. Refer to ["4.4 Radiator"](#), page 139 .
- After replacing, replace the entire amount of coolant.

4 - Gasket

5 - Cap

- Check using the Cooling System Tester - VAG1274B- and the adapter - VAG1274/9- . Refer to ["page 132"](#) .
- The pressure relief valve must open at 1.4 to 1.6 bar (20.30 to 23.20 psi).

6 - Connector

7 - Bolt

- 3 Nm

8 - Expansion Tank

- Perform a leak test on the cooling system using the Cooling System Tester - VAG1274B- and the Adapter - VAG1274/8- . Refer to ["3.1 Cooling System, Checking for Leaks"](#), page 132 .

9 - Bracket

- For the radiator.

10 - Bolt

- 5 Nm

11 - Spacer Piece

- For the refrigerant line bracket.

12 - Support

- Insert in the lock carrier.

13 - Nut

- 5 Nm

14 - Fan Shroud

15 - Bolt

- 5 Nm

16 - Coolant Fan 2 - V177-

- Removing and installing. Refer to ["4.3 Fan Shroud and Fan"](#), page 138 .

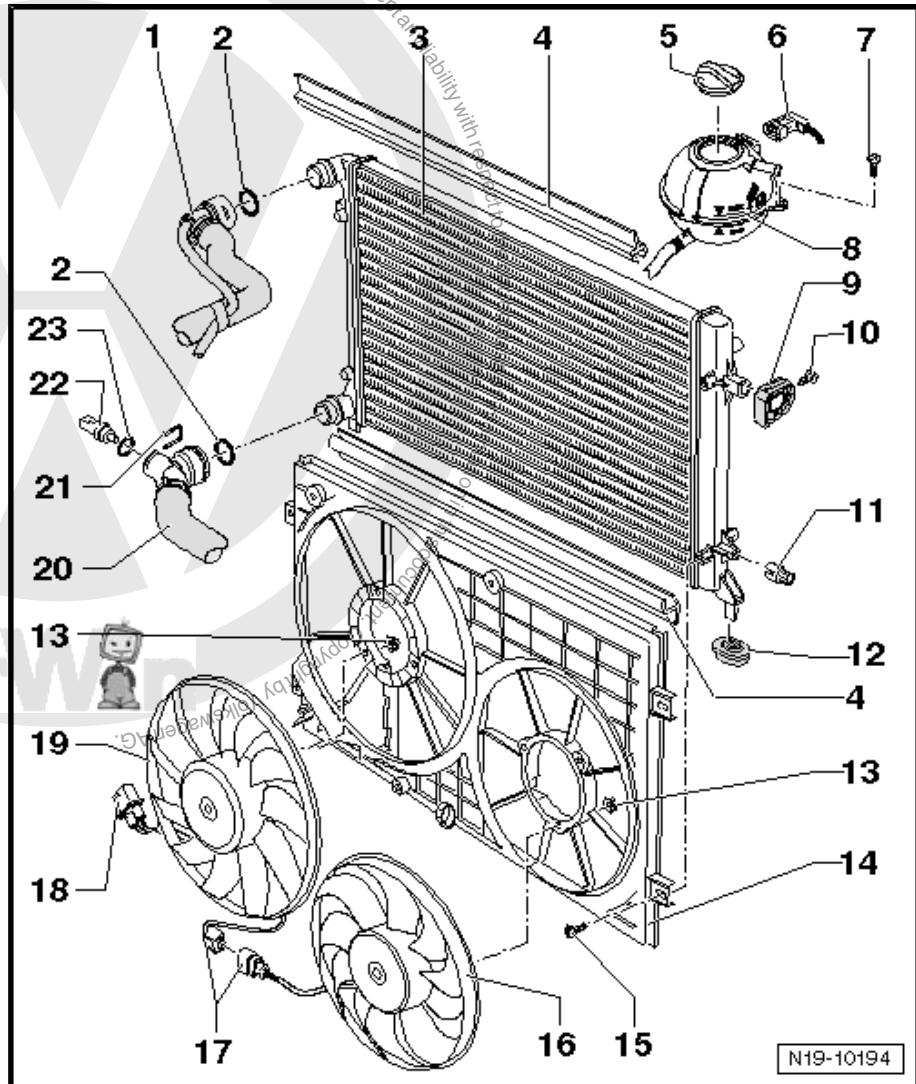



17 - Connector

18 - Connector

19 - Coolant Fan - V7-

- Removing and installing. Refer to ⇒ [“4.3 Fan Shroud and Fan”, page 138](#) .
- With the Coolant Fan Control Module - J293- .

20 - Lower Coolant Hose

- From the connection for the coolant flange.

21 - Retaining Clip

22 - Engine Coolant Temperature Sensor on Radiator Outlet - G83-

23 - O-Ring

- Always replace.





3 Diagnosis and Testing

⇒ "3.1 Cooling System, Checking for Leaks", page 132

3.1 Cooling System, Checking for Leaks

Special tools and workshop equipment required

- ◆ Cooling System Tester - VAG1274B-
- ◆ Adapter - VAG1274/8-
- ◆ Adapter - VAG1274/9-

Test Conditions

- The engine is at operating temperature

Test Sequence



WARNING

Steam can be released when the cap is removed from the expansion tank. Cover the cap with a cloth and open carefully.

- Open the cap on the coolant expansion tank.
- Install the Adapter - VAG1274/8- onto the coolant expansion tank.
- Clamp the Connecting Piece - VAG1274B/1- on the Adapter - VAG1274/8- .
- Connect the Connector Piece - VAG1274B/1- to the Cooling System Tester - VAG1274B- using the connecting hose.
- Generate a positive pressure of approximately 1.0 bar (14.5 psi) using the tester hand pump.



DANGER!

Risk of scalding! Reduce the pressure before disconnecting the Cooling System Tester - VAG1274B- from the connecting hose or Connector Piece - VAG1274B/1-. To do this, press the pressure release valve on the Cooling System Tester - VAG1274B- until the pressure gauge displays 0.

If the pressure drops:

- Look for leaks and correct.

Checking the Pressure Relief Valve in the Cap

- Install the cap to the Adapter - VAG1274/9- .
- Clamp the Connecting Piece - VAG1274B/1- on the Adapter - VAG1274/9- .

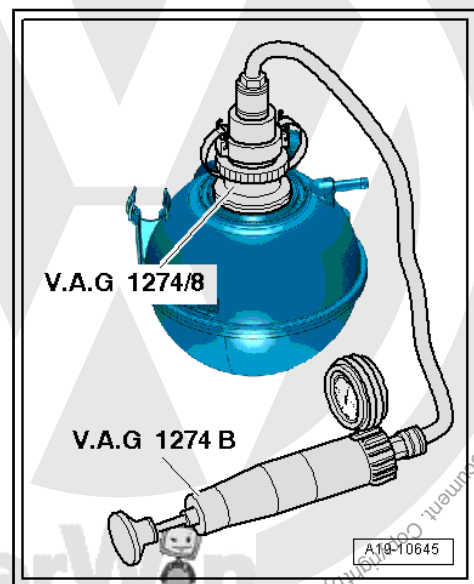



- Connect the Connector Piece - VAG1274B/1- to the Cooling System Tester - VAG1274B- using the connecting hose.
- Actuate the hand pump.
- The pressure release valve must open at 1.4 to 1.6 bar (20.30 to 23.20 psi).

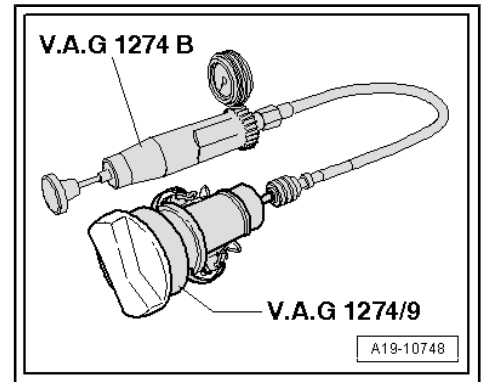



4 Removal and Installation

⇒ [“4.1 Coolant Thermostat”, page 134](#)

⇒ [“4.2 Coolant Pump”, page 135](#)

⇒ [“4.3 Fan Shroud and Fan”, page 138](#)

⇒ [“4.4 Radiator”, page 139](#)

4.1 Coolant Thermostat



Note

Checking the coolant thermostat, see item 17- in Part 1. Refer to
⇒ [“2.2 Coolant Pump and Thermostat Overview”, page 125](#).

Special tools and workshop equipment required

- ◆ Adapter - VAG1274/8-
- ◆ Shop Crane - Drip Tray - VAS6208-
- ◆ Hose Clip Pliers - VAS6362-
- ◆ Cooling System Charge Unit - VAS6096-
- ◆ Refractometer - T10007-

Removing



WARNING

Hot steam may escape when opening the expansion tank cap. Wear protective goggles and protective clothing to prevent damage to eyes and scalding. Cover the cap with a cloth and open very carefully.

- Drain the coolant. Refer to
⇒ [“1.1 Coolant, Draining and Filling”, page 121](#).
- Remove the engine cover with air filter. Refer to
⇒ [“5.1 Engine Cover with Air Filter”, page 159](#).
- Remove the intake manifold. Refer to
⇒ [“5.3 Intake Manifold”, page 161](#).
- Reinsert the oil dipstick guide tube in the cylinder block. Tighten the bolt to prevent coolant from leaking into the engine.
- Place a suitable container under the coolant thermostat housing to catch any coolant leaking out.
- Remove the bolts -arrows-, the cover -A- and the thermostat.

Installing

Install in reverse order of removal. Note the following:

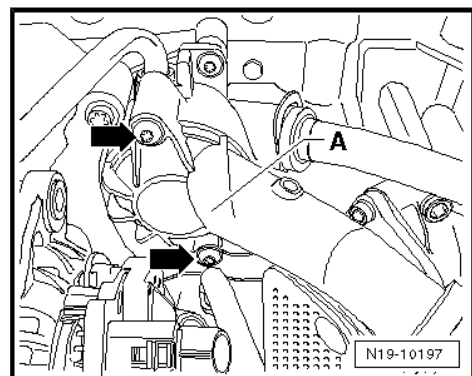



- ◆ Replace the O-ring and seal, see items -16 and 18- in Part 1. Refer to
 ⇒ ["2.2 Coolant Pump and Thermostat Overview", page 125](#) .
- ◆ Note the installed position of the thermostat -1-. The valve -2- must point upward.
- ◆ Fill the coolant. Refer to
 ⇒ ["1.1 Coolant, Draining and Filling", page 121](#) .

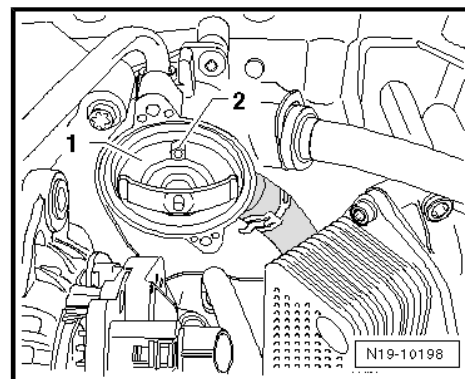

Tightening Specifications

Component	Nm
Cover to coolant thermostat housing	5

4.2 Coolant Pump

Special tools and workshop equipment required

- ◆ Engine Support Bridge - 10-222A-
- ◆ Engine Support Adapter - 10-222A/3-
- ◆ Engine Support Feet - 10-222A/8-
- ◆ Shackle - 10-222A/12-
- ◆ Torque Wrench (5-50 Nm) - VAG1331-
- ◆ Torque Wrench (40-200 Nm) - VAG1332-



Caution

When doing any repair work, especially in the engine compartment, pay attention to the following due to clearance issues:

- ◆ *Route all lines and wires in their original locations.*
- ◆ *Make sure there is enough clearance to moving or hot components to prevent damage to the lines.*

Removing

- Remove the engine cover with air filter. Refer to
 ⇒ ["5.1 Engine Cover with Air Filter", page 159](#) .
- Remove the battery. Refer to ⇒ Electrical Equipment; Rep. Gr. 27 ; Removal and Installation .



- Remove the cover -1- for the E-box and remove the wire -2-.
- Remove the bolts -arrows- and remove the battery tray.



WARNING

Hot steam may escape when opening the expansion tank cap. Wear protective goggles and protective clothing to prevent damage to eyes and scalding. Cover the cap with a cloth and open very carefully.

- Drain the coolant. Refer to [⇒ "1.1 Coolant, Draining and Filling", page 121](#) .

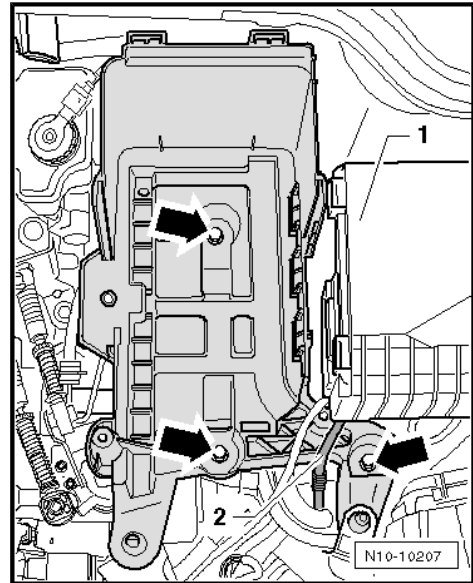

- Remove the connecting pipe -4-. To do so, disconnect the Secondary Air Injection (AIR) connecting pipe -1-, if equipped and the vent tube -2- and reposition the spring clamp -3-.
- Remove the right front wheel housing liner. Refer to ⇒ Body Exterior; Rep. Gr. 66 ; Removal and Installation .
- Remove the generator, power steering pump and coolant pump ribbed belt. Refer to ⇒ ["5.1 Ribbed Belt", page 45](#) .

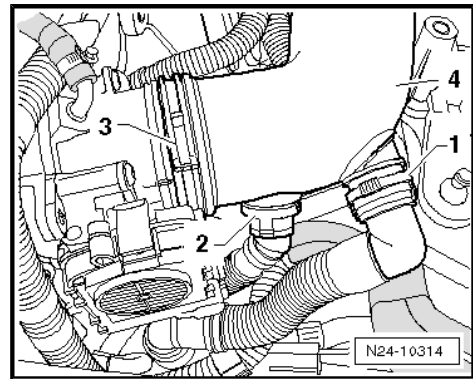

- Remove the 4 exhaust pipe with catalytic converter to exhaust manifold nuts -2- and the suspended mount bolts -3-.
- Remove the exhaust pipe with catalytic converter -1- from the manifold and tie up firmly to the side. Refer to [⇒ "4.3 Exhaust Pipe with Catalytic Converter", page 189](#) .

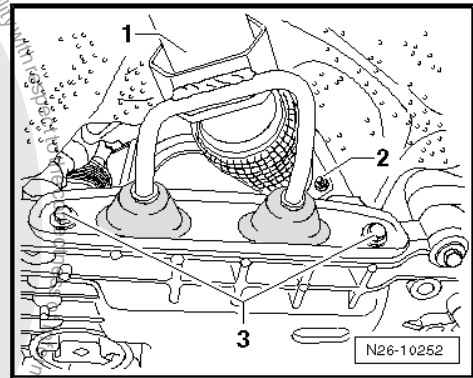

Note

The coupling element in the exhaust pipe with catalytic converter must not be bent more than 10°, otherwise it may be damaged.

Remove the pendulum support. Refer to ⇒ Suspension, Wheels, Steering; Rep. Gr. 40 ; Description and Operation .

With a Manual Transmission

- Remove the shift mechanism from the transmission. Refer to ⇒ Manual Transmission; Rep. Gr. 34 ; Removal and Installation .

With a Automatic Transmission

- Remove the selector lever cable from the transmission. Refer to ⇒ Automatic Transmission; Rep. Gr. 37 ; Removal and Installation .

Installing the Engine Support Bridge - 10-222A- , Rabbit, from MY 2006 through 2009



- Position the Engine Support Bridge - 10-222A- with the Engine Support Feet - 10-222A/8- . Support the engine and transmission assembly in the installed position using the Engine Support Adapter - 10-222A/3- and the Shackle - 10-222A/12- .

i Note

- ◆ The illustration shows the arrangement with a automatic transmission.
- ◆ In vehicles with a manual transmission, the spindle -A- is to be located toward the rear and secured to the reinforcement brace of the transmission.

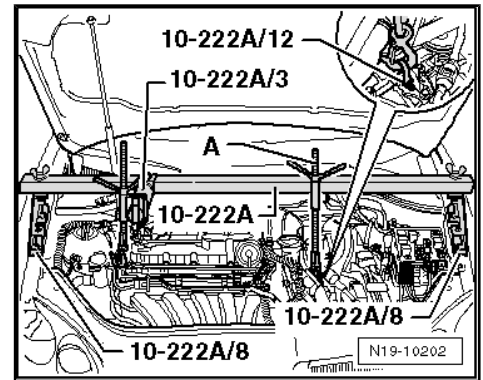

Installing the Engine Support Bridge - 10-222A- , Golf, from MY 2010

- Position the Engine Support Bridge - 10-222A- with the Engine Support Feet - 10-222A/8- . Support the engine and transmission assembly in the installed position as illustrated.

Note the following:

- The panel -A- must not be bent.
- Secure the Shackle - 10-222A/12- on the reinforcing brace in vehicles with a manual transmissions and at the transport eye in vehicles with a automatic transmissions.

Continuation for All

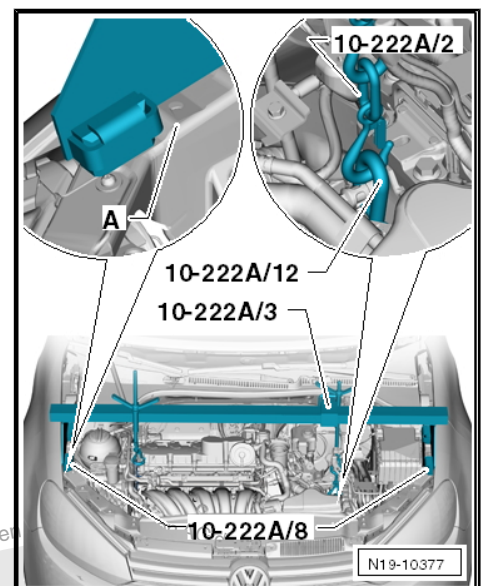

- Remove the bolt -2- and move the windshield washer fluid reservoir -1- toward the front.
- Remove the bolts -6- and disconnect the connector -3-.
- Remove the bolts -5- and place the coolant expansion tank on top of the engine with the hoses connected.

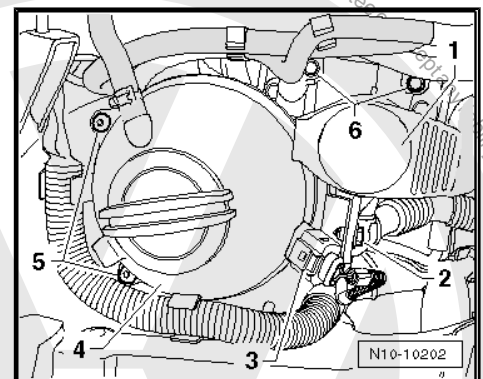

- Remove the bolts -1, 2 and 3- and remove the engine mount.

i Note

Remove the single, lower rear bolt -2- through a hole in the wheel housing.

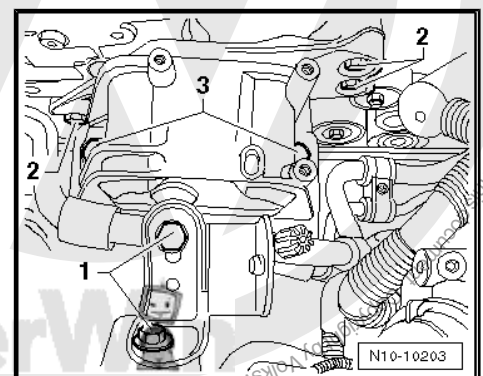



- Remove the transmission mount to transmission mount bracket bolts -arrows-.
- Slide the engine as far as possible toward the front and to the left.

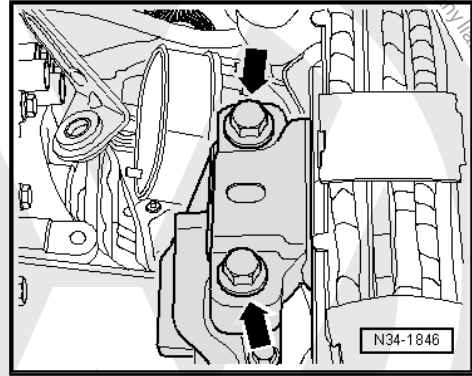

- Remove the 3 coolant pump bolts and swivel the coolant pump -A- out as shown.

Installing

Install in reverse order of removal. Note the following:

- ◆ Note the installed position of the coolant pump. The sealing plug in the housing points downward.
- ◆ Fill the coolant. Refer to ⇒ ["1.1 Coolant, Draining and Filling", page 121](#) .
- ◆ Install the battery. Refer to ⇒ Electrical Equipment; Rep. Gr. 27 ; Removal and Installation .

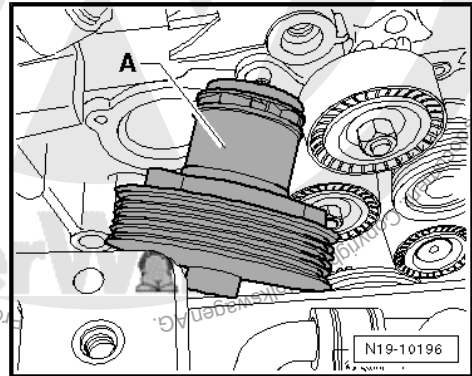

Tightening Specifications

Component	Nm
Engine and transmission mount bolts	Refer to ⇒ "1.1 Fastener Tightening Specifications", page 7 .
Coolant pump to cylinder block	10

4.3 Fan Shroud and Fan

Removing

- Remove the fan shroud upper bolts -arrows-.
- Remove the noise insulation. Refer to ⇒ Body Exterior; Rep. Gr. 50 ; Removal and Installation .
- Unclip the lower coolant hose from the fan shroud.
- Disconnect the electrical connector -1- and remove the fan shroud lower bolts -arrows-.
- Remove the fan shroud downward.

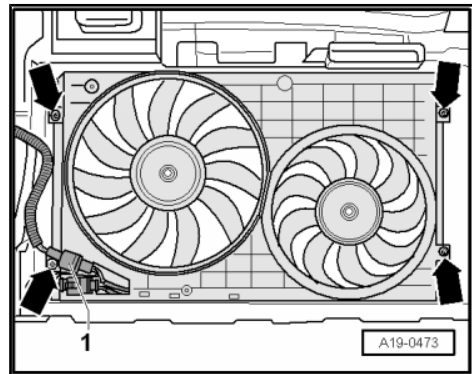



- Disconnect the electrical connector -1- and lay the wire free. Installed position of the connector deviates from the illustration.
- Remove the coolant fan nuts -arrows- and remove the fans.

Installing

Install in reverse order of removal. Note the following:

Tightening Specifications

Component	Nm
Coolant fan to fan shroud	5
Fan shroud to radiator	5

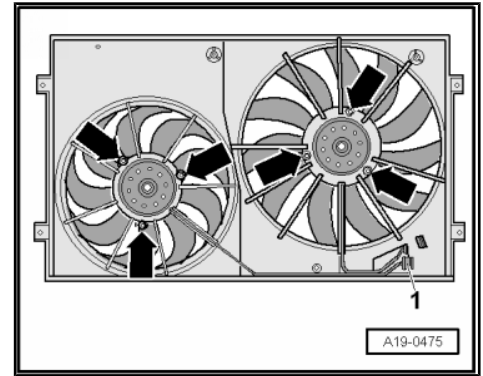

4.4 Radiator

Special tools and workshop equipment required

- ◆ Adapter - VAG1274/8-
- ◆ Drip Tray for VAS6100 - VAS6208-
- ◆ Hose Clip Pliers - VAS6362-
- ◆ Cooling System Charge Unit - VAS6096-
- ◆ Refractometer - T10007A-

Removing

- Remove the front bumper cover. Refer to => Body Exterior; Rep. Gr. 63 ; Removal and Installation .
- Remove the fan shroud and fans. Refer to => "4.3 Fan Shroud and Fan", page 138 .
- Drain the coolant. Refer to => "1.1 Coolant, Draining and Filling", page 121 .
- Remove the coolant hoses from the radiator.



Caution

To prevent damage to the Air Conditioning (A/C) condenser and the refrigerant lines, do not stretch, kink or bend the lines and hoses.

- Remove the lock carrier to radiator bracket bolts -arrows-.

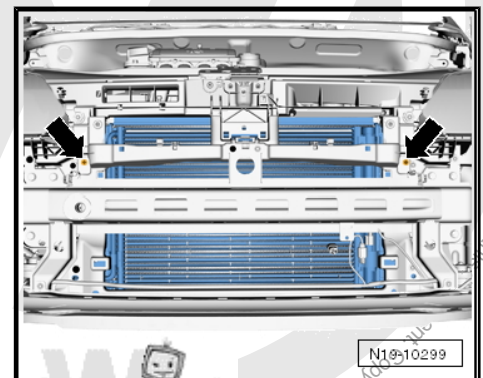



- Move the radiator and A/C condenser toward the rear and out of the lower mount. While doing this, pull the lock carrier on the left mount -1- slightly downward.

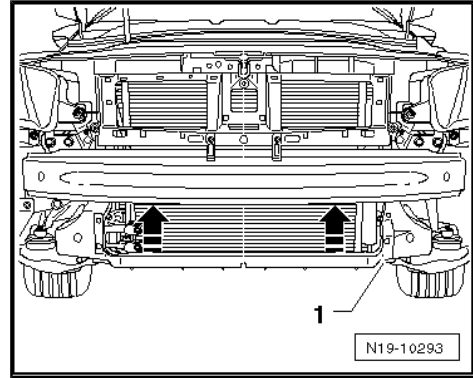

- Remove the bolts for the refrigerant lines on the right side of the radiator -arrow-.
- Remove the A/C condenser bolts. Secure the A/C condenser on the lock carrier using cable ties, for example.
- Remove the radiator downward.

Installing

- Install the radiator from below and secure it to the A/C condenser.
- Install the radiator and A/C condenser in the lower mounts.

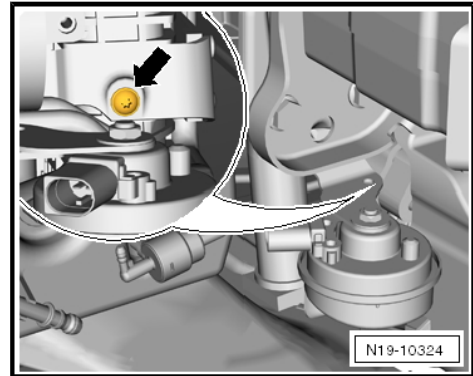

- Place the radiator upper bracket on the radiator and secure it to the lock carrier -arrows-.
- Install the front bumper cover . Refer to => Body Exterior; Rep. Gr. 63 ; Removal and Installation .
- Install the fan shroud and fans. Refer to => ["4.3 Fan Shroud and Fan", page 138](#) .

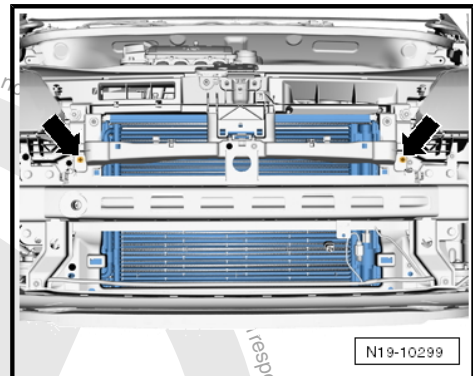

Further installation is performed in reverse order of removal. Note the following:

- ◆ Replace the coolant if a new radiator was installed.
- ◆ Fill the coolant. Refer to => ["1.1 Coolant, Draining and Filling", page 121](#) .

Tightening Specifications

Component	Nm
Lock carrier to radiator bracket	5
A/C condenser to radiator	5
Fan shroud to radiator	5



5 Special Tools

Special tools and workshop equipment required

- ◆ Cooling System Tester - VAG1274B-

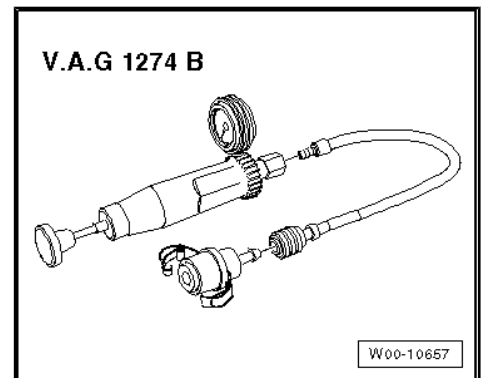

- ◆ Adapter - VAG1274/9-

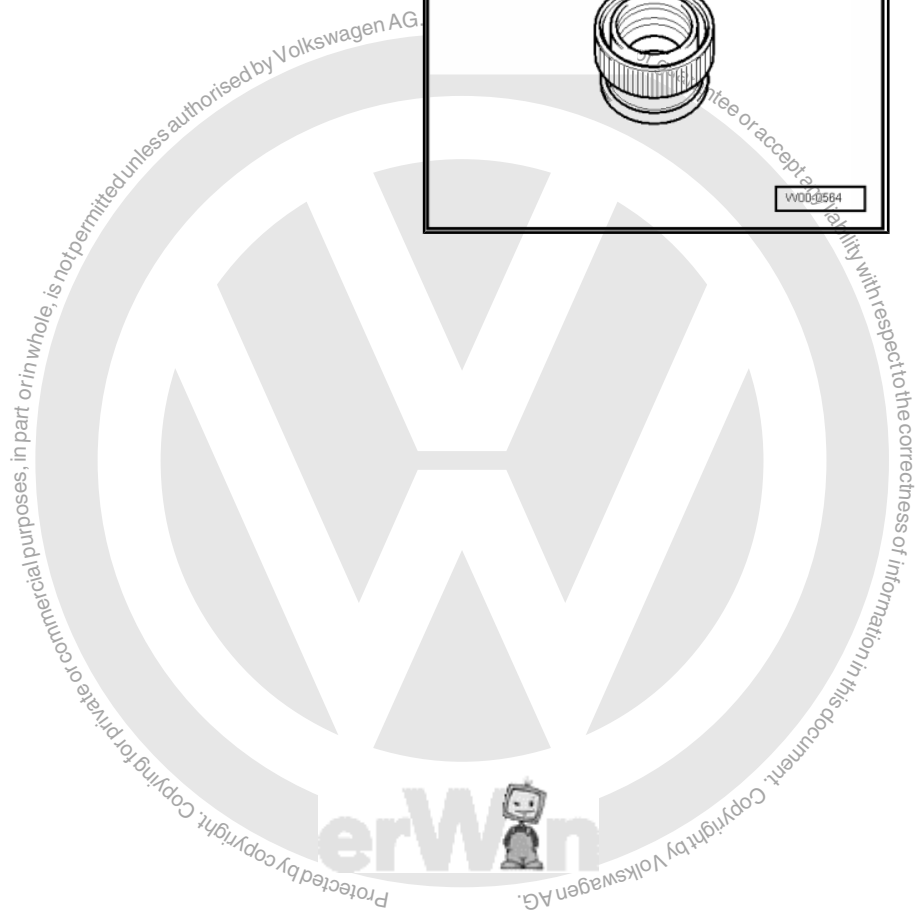
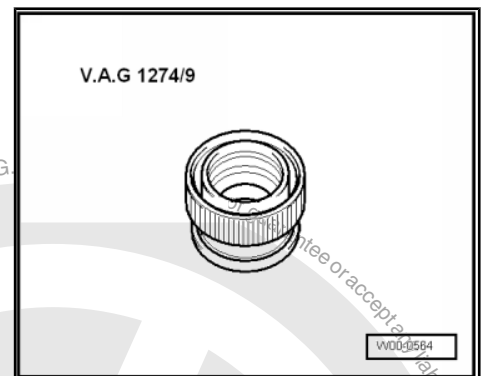



- ◆ Adapter - VAG1274/8-
- ◆ Shop Crane - Drip Tray - VAS6208-
- ◆ Hose Clip Pliers - VAS6362-
- ◆ Cooling System Charge Unit - VAS6096-
- ◆ Refractometer - T10007A-

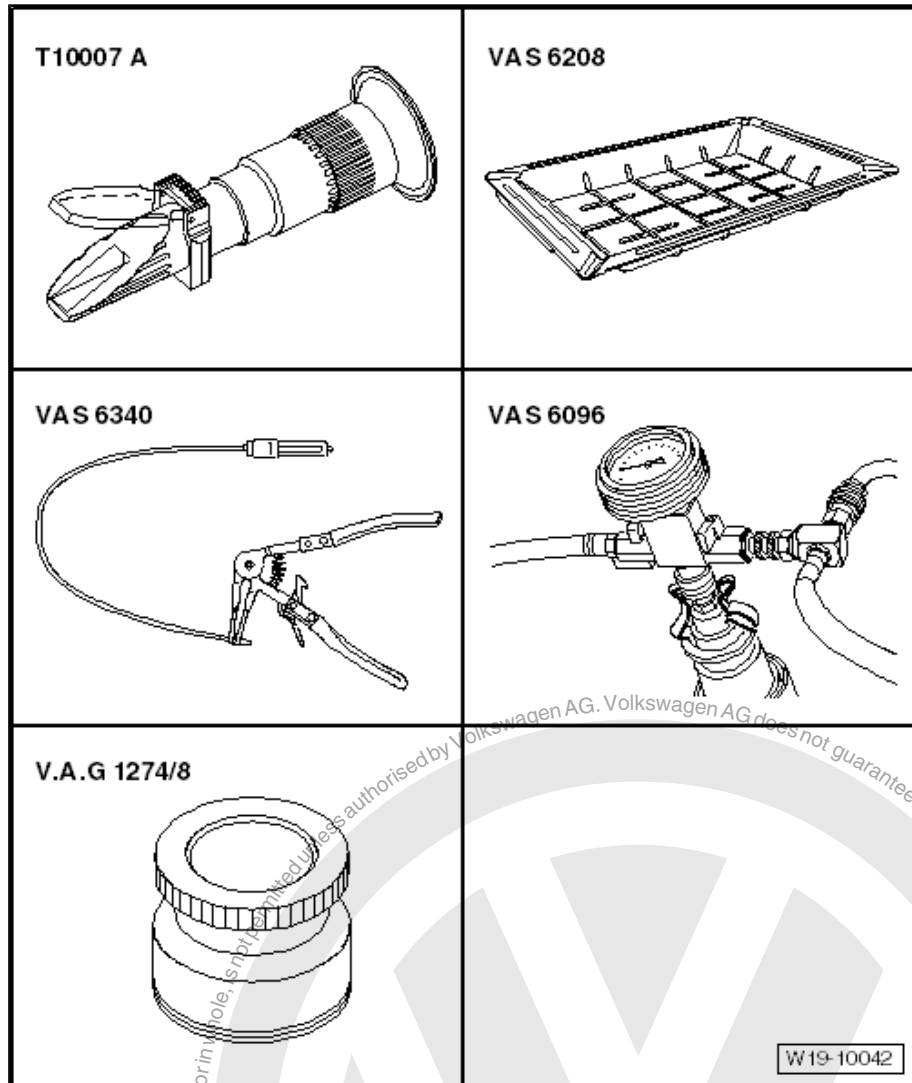



Protected by copyright. Copying for private or commercial purposes, in part or in whole, is prohibited unless authorised by Volkswagen AG. Volkswagen AG does not guarantee or accept any liability with respect to the correctness of information in this document. Copyright by Volkswagen AG.



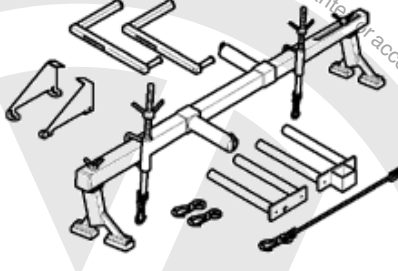
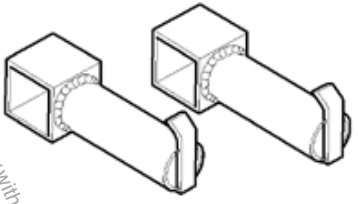
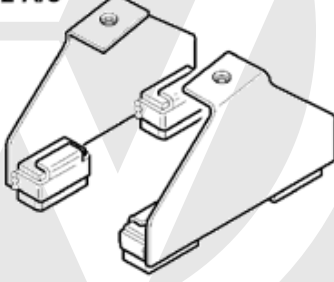
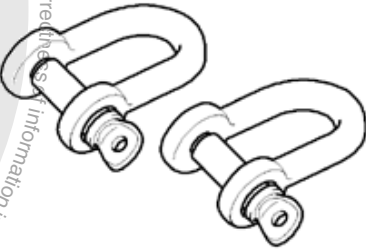
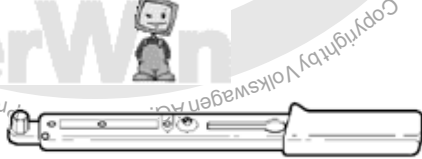

- ◆ Engine Support Bridge - 10-222A-
- ◆ Engine Support Adapter - 10-222A/3-
- ◆ Engine Support Feet - 10-222A/8-
- ◆ Shackle - 10-222A/12-
- ◆ Torque Wrench (5-50 Nm) - VAG1331-
- ◆ Torque Wrench (40-200 Nm) - VAG1332-

<p>10-222 A</p> 	<p>10-222 A/3</p> 
<p>10-222 A/8</p> 	<p>10-222 A/12</p> 
<p>V.A.G 1331</p> 	<p>V.A.G 1332</p> 

W19-10008



24 – Multiport Fuel Injection

1 General Information

⇒ **“1.1 Fuel System, Filling and Bleeding”, page 144**

1.1 Fuel System, Filling and Bleeding

Special tools and workshop equipment required

- ◆ Adapter for K-jetronic Test Device - VAG1318/20-
- ◆ Suction Pump - VAS5226-
- ◆ Vehicle Diagnostic, Testing, and Information System - VAS5051B-



Note

- ◆ *If the fuel supply system was opened, it must always be bled before starting the engine.*
- ◆ *If the fuel supply system is not bled, the catalytic converter will be damaged.*
- ◆ *Pay attention to the rules of cleanliness. Refer to ⇒ **“1.2 Clean Working Conditions”, page 3**.*

Procedure



WARNING

The fuel supply line is under pressure. Always wear protective eyewear and protective clothing to prevent injuries and fuel from coming in contact with your skin. Before loosening the fuel lines, place a cloth around the connection point. Remove the hose connection carefully to release the pressure.

- Remove the cap -arrow- for the bleed valve.

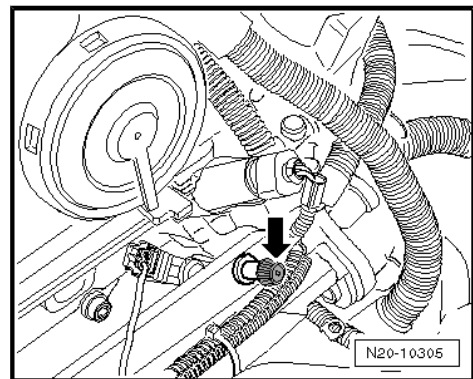



- Turn the valve on the T-piece counterclockwise until it is completely open.
- Install Adapter - VAG1318/20-1- onto the Adapter for K-Jetronic Test Device - VAG1318/20- .
- Install the Adapter - VAG1318/20- hand tight onto the bleed valve.

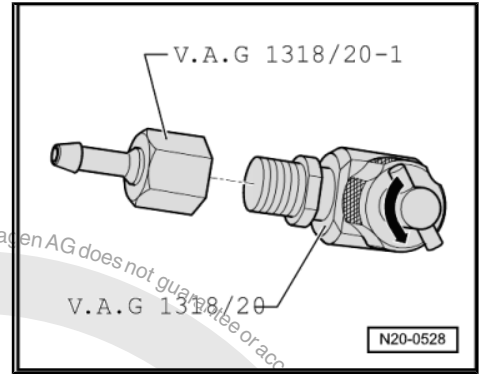

- Connect the hose from the Suction Pump - VAS5226- as shown.
- Turn the valve (at the T-piece) clockwise into the bleed valve until seated.
- Check the adapter and hose connections for leaks.

Connect the vehicle diagnostic tester as follows:

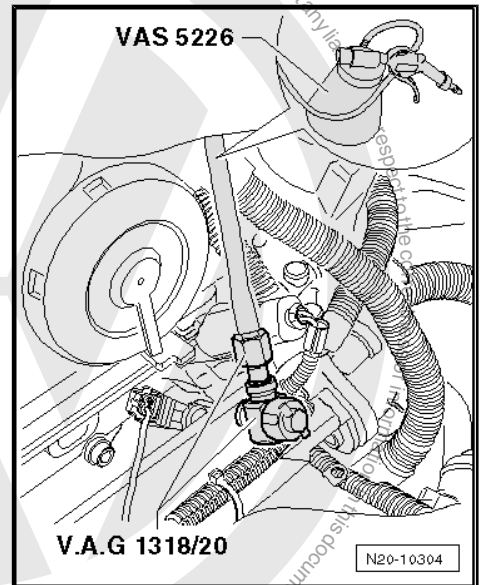

- Connect the diagnostic cable connector -2- to the diagnostic connection inside the drivers foot well.
- Press the following buttons on the display one after another:

- Press the arrow button repeatedly until the Fuel Pump Relay - J17- is activated. This activates the fuel pump. Let the diagnosis run until fuel flows out of the bleed valve without bubbles. Then end the output diagnostic test mode.

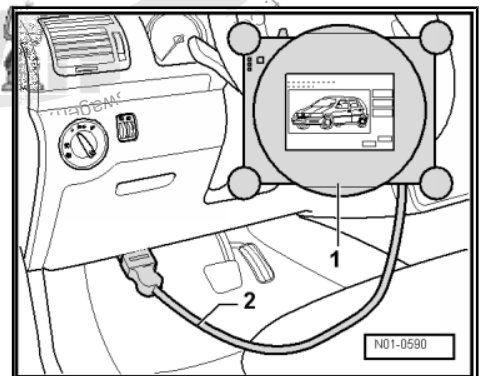

i Note

If the output diagnostic test mode is interrupted, the engine must be started for a short time before the mode can be accessed again. The output diagnostic test mode is automatically cancelled after 60 seconds.



- Turn the valve at the T-piece counterclockwise until it is completely open again.
- Clamp off the hose on the Suction Pump - VAS5226- using a Hose Clamp Up to 25 mm - 3094- and disconnect it from the Adapter - VAG1318/20-1- .
- Remove the Adapter for K-jetronic Test Device - VAG1318/20- from the bleed valve.

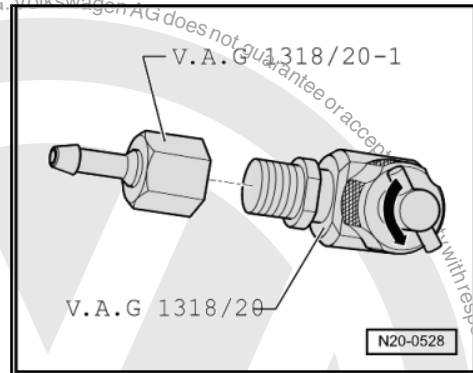

- Install the cap -arrow- on the bleed valve.

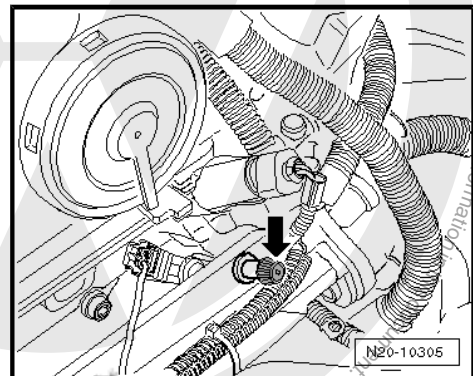



2 Description and Operation

⇒ [“2.1 Fuel Injection System Component Location Overview”, page 147](#)

⇒ [“2.2 Engine Cover with Air Filter Overview”, page 150](#)

Engine Codes BGP and BGQ

⇒ [“2.3 Intake Manifold Overview”, page 152](#)

⇒ [“2.4 Fuel Rail and Injectors Overview”, page 153](#)

Engine Codes CBTA and CBUA

⇒ [“2.5 Intake Manifold Overview”, page 154](#)

⇒ [“2.6 Fuel Rail and Injectors Overview”, page 155](#)

2.1 Fuel Injection System Component Location Overview



Note

The Mass Airflow Sensor - G70- is no longer installed from MY 2009. The Intake Air Temperature Sensor - G42- is installed on the intake manifold with the Manifold Absolute Pressure Sensor - G71- .

The Following Components Are Not Displayed in the Overview:

Manifold Absolute Pressure (MAP) sensor

Accelerator Pedal Position Sensor - G79- / Accelerator Pedal Position Sensor 2 - G185-

Leak Detection Pump - V144-

Clutch Position Sensor - G476-





1 - Fuel Injectors - N30, N31, N32, N33, N83-

- Removing and installing. Refer to [⇒ "5.4 Fuel Injectors", page 164](#) .

2 - Camshaft Position Sensor - G40-

3 - 81 Pin Connector

- Disconnect and connect the connector with the ignition turned off.
- Release to disconnect.

4 - Engine Control Module - J623-

- Installed location: In the plenum chamber.

5 - 40 Pin Connector

- Disconnect and connect the connector with the ignition turned off.
- Release to disconnect.

6 - Secondary Air Injection Solenoid Valve - N112-

- For Secondary Air Injection (AIR).
- Checking. Refer to [⇒ "3.1 Secondary Air Injection Solenoid Valve, Checking", page 186](#) .

7 - Engine Coolant Temperature Sensor - G62-

- If necessary release pressure in the cooling system before removing.

8 - EVAP Canister Purge Regulator Valve 1 - N80-

- Installed position: The arrow points in the direction of flow.

9 - Ignition Coil with Power Output Stage - N70, N127, N291, N292, N323-

- Removing and installing. Refer to [⇒ "3.1 Ignition Coil with Power Output Stage", page 199](#) .

10 - MAF Sensor

- The MAF sensor is no longer installed from MY 2009. The IAT sensor is installed on the intake manifold with the Manifold Absolute Pressure (MAP) sensor.

11 - E-Box, in Engine Compartment, Left Side

Component location of:

- Secondary Air Injection Pump Relay - J299- . Refer to [⇒ Fig. "Secondary Air Injection Pump Relay", page 150](#) .
- Fuel pump relay. Refer to [⇒ Fig. "Fuel Pump Relay", page 150](#) .
- Terminal 30 Power Supply Relay - J317- . Refer to [⇒ Fig. "Terminal 30 Power Supply Relay", page 150](#) .
- Terminal 15 Power Supply Relay - J329- . Refer to [⇒ Fig. "Terminal 15 Power Supply Relay", page 150](#) .
- Fasteners

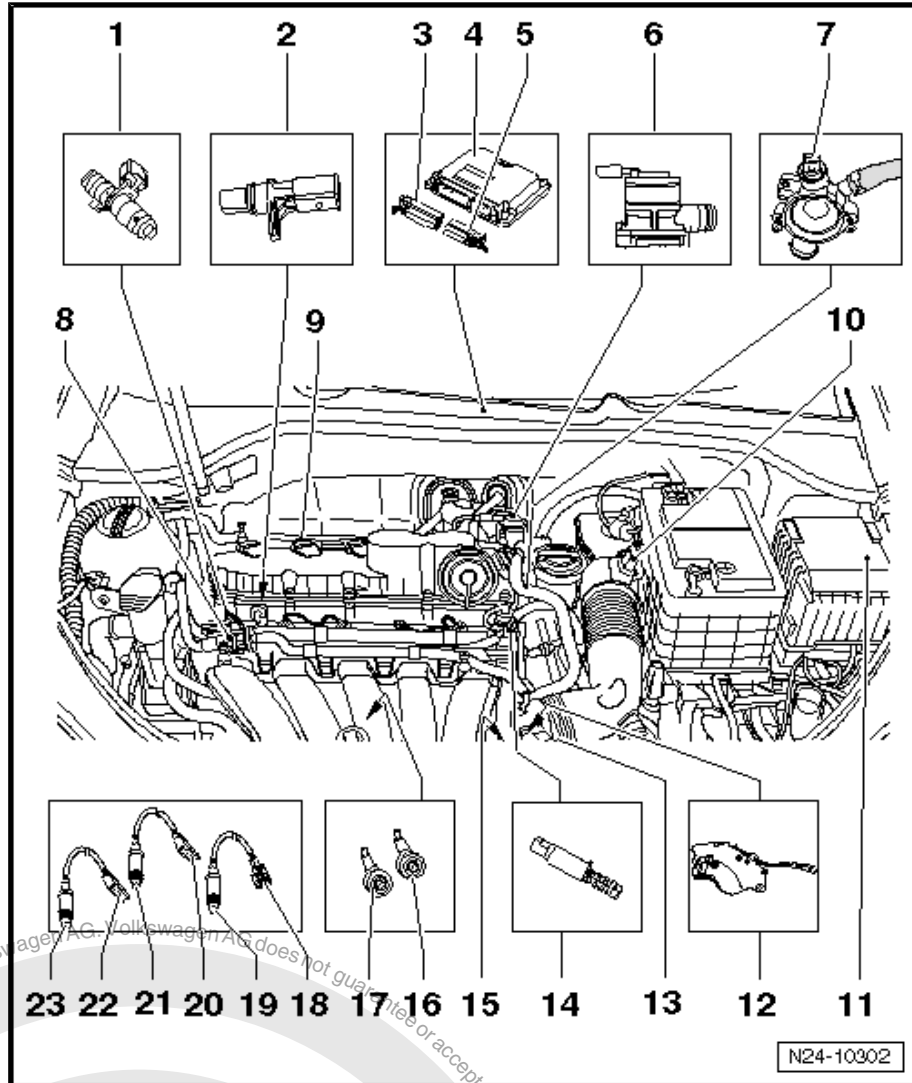



12 - Engine Speed Sensor - G28-

- Secured to sealing flange, transmission side.

13 - Throttle Valve Control Module - J338-

- Removing and installing. Refer to ⇒ [“5.2 Throttle Valve Control Module J338”](#), page 159 .

14 - Camshaft Adjustment Valve 1 - N205-

15 - Secondary Air Injection Pump Motor - V101-

- Removing and installing. Refer to ⇒ [“4.1 Secondary Air Injection Pump Motor V101”](#), page 187 .

16 - Knock Sensor 1 - G61-

- Component location. Refer to ⇒ [“2.3 Engine Overview, Rear”](#), page 30 .

17 - Knock Sensor 2 - G66-

- Component location. Refer to ⇒ [“2.3 Engine Overview, Rear”](#), page 30 .

18 - 6 Pin Harness Connector

- Contacts are gold plated.
- Black
- For the heated oxygen sensor before the catalytic converter and the Oxygen Sensor Heater - Z19- .
- Installed location: Secured to the left plenum chamber bulkhead.

19 - Heated Oxygen Sensor - G39-

- 55 Nm
- Installed location: in the exhaust manifold
- Only use hot bolt paste to grease the threads, do not let the paste get onto the slits of the oxygen sensor body.

20 - 4 Pin Harness Connector

- Only with engine codes BGQ and CBUA.
- Contacts are gold plated.
- Black
- For the oxygen sensor in bank 1 center three way catalytic converter and the Heater For Oxygen Sensor Center Catalytic Converter - Z59- .
- Component location. Refer to ⇒ [“4.3 Exhaust Pipe with Catalytic Converter”](#), page 189 .

21 - Oxygen Sensor in Bank 1 Center Three Way Catalytic Converter - G465-

- 55 Nm
- Only with engine codes BGQ and CBUA.
- Installed location: in the center catalytic converter.
- Only use hot bolt paste to grease the threads, do not let the paste get onto the slits of the oxygen sensor body.

22 - 4 Pin Harness Connector

- Contacts are gold plated.
- Brown
- For the oxygen sensor after three way catalytic converter and Heater For Oxygen Sensor 1 After Catalytic Converter - Z29- .
- Component location. Refer to ⇒ [“4.3 Exhaust Pipe with Catalytic Converter”](#), page 189 .

23 - Oxygen Sensor After Three Way Catalytic Converter - G130-

- 55 Nm
- Installed location: in the rear catalytic converter.
- Only use hot bolt paste to grease the threads, do not let the paste get onto the slits of the oxygen sensor body.



Secondary Air Injection Pump Relay

- ◆ In the E-box in the engine compartment, at the lower right -1-

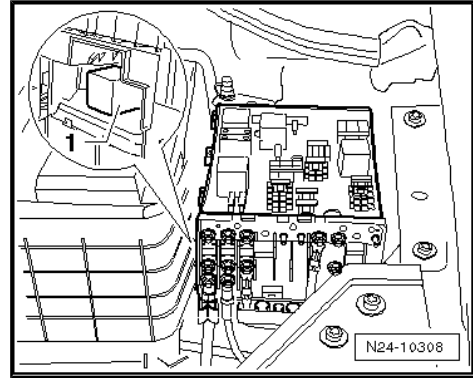

Terminal 30 Power Supply Relay

- ◆ In the E-box in the engine compartment -1-

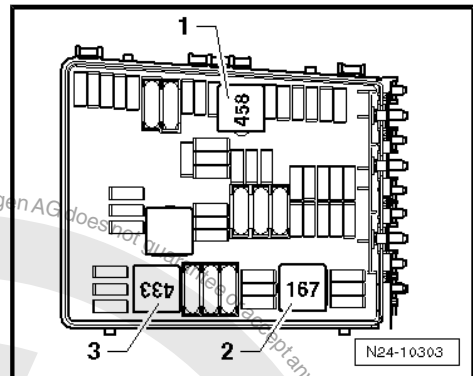

Fuel Pump Relay

- ◆ In the E-box in the engine compartment -2-

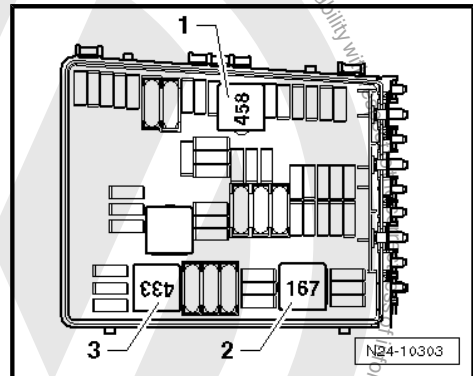

Terminal 15 Power Supply Relay

- ◆ In the E-box in the engine compartment -3-

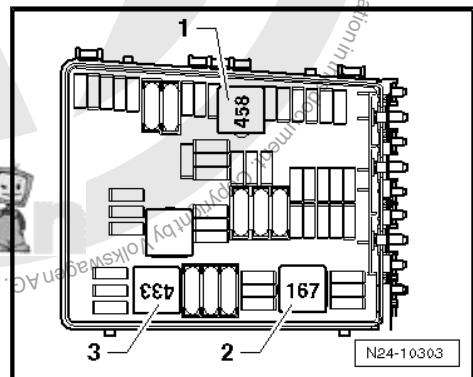

2.2 Engine Cover with Air Filter Overview

The upper air filter housing is also the engine cover.

Engine cover with air filter, removal and installation. Refer to [⇒ "5.1 Engine Cover with Air Filter", page 159](#) .



1 - To the Throttle Valve Control Module - J338-

2 - Spring Type Clamp

3 - Connection

- For the vent hose from the oil filter adapter.

4 - Connection

- For the connecting pipe from the Secondary Air Injection (AIR) pump.

5 - Connecting Pipe

- To the throttle valve control module.

6 - Mass Airflow Sensor - G70- with Intake Air Temperature Sensor - G42-

- The Mass Airflow (MAF) sensor is no longer installed from MY 2009. The Intake Air Temperature (IAT) sensor is installed on the intake manifold with the Manifold Absolute Pressure Sensor - G71- .

7 - Bolt

- 3 Nm

8 - From the Air Duct on the Lock Carrier

9 - Bolt

- 1.5 Nm

10 - Intake Air Duct

- To the air filter.

11 - Upper Air Filter Housing/Engine Cover

12 - Rubber Bushing

- Do not use lubricant.

13 - Filter Element

14 - Lower Air Filter Housing

- The warm air intake has been discontinued with engine codes CBTA and CBUA.

15 - Bolt

- 2 Nm

- Follow the tightening sequence. Refer to

[⇒ Fig. "Lower Air Filter Housing Bolt Tightening Sequence" , page 152 .](#)

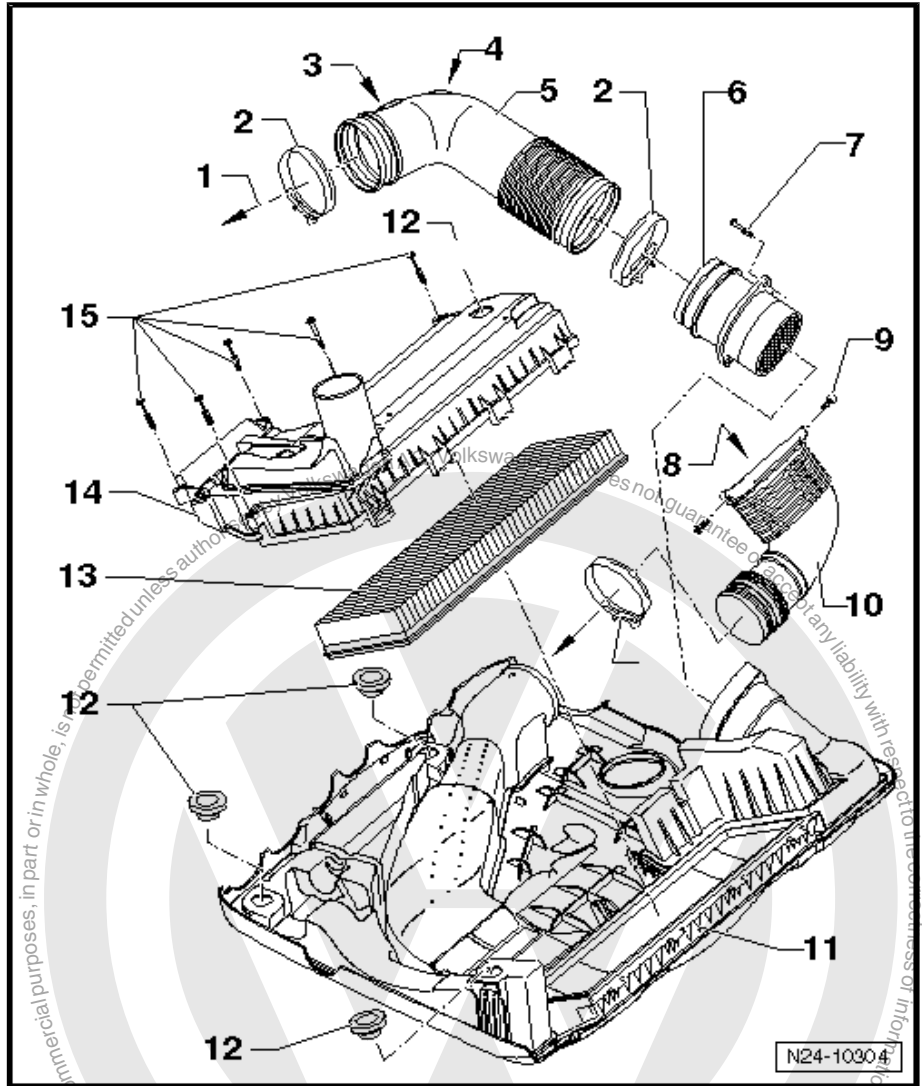



Lower Air Filter Housing Bolt Tightening Sequence

- Tighten the bolts, as shown, in sequence -1 through 5- to 2 Nm.

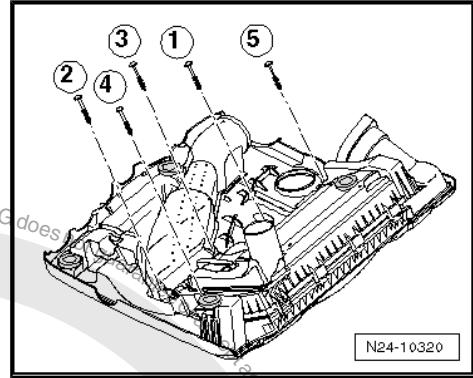

2.3 Intake Manifold Overview

- 1 - Vent Hose
 - From the cylinder head cover.
- 2 - Ventilation Hose
- 3 - EVAP Canister Purge Regulator Valve 1 - N80-
- 4 - Vacuum Hose
 - From the Leak Detection Pump - V144
- 5 - Bolt
 - 9 Nm
- 6 - Fuel Rail
 - Overview. Refer to ["2.4 Fuel Rail and Injectors Overview", page 153](#).
- 7 - Fuel Supply Line
- 8 - Gasket
 - Always replace.
 - Note the installed position:
Casting mark points upward.
- 9 - Intake Manifold
 - Removing and installing. Refer to ["5.3 Intake Manifold", page 161](#).
- 10 - Rubber Bushing
- 11 - Intake Manifold Support
- 12 - Bolt
 - 25 Nm
- 13 - Nut
 - 20 Nm
- 14 - O-Ring
 - Replace if damaged.

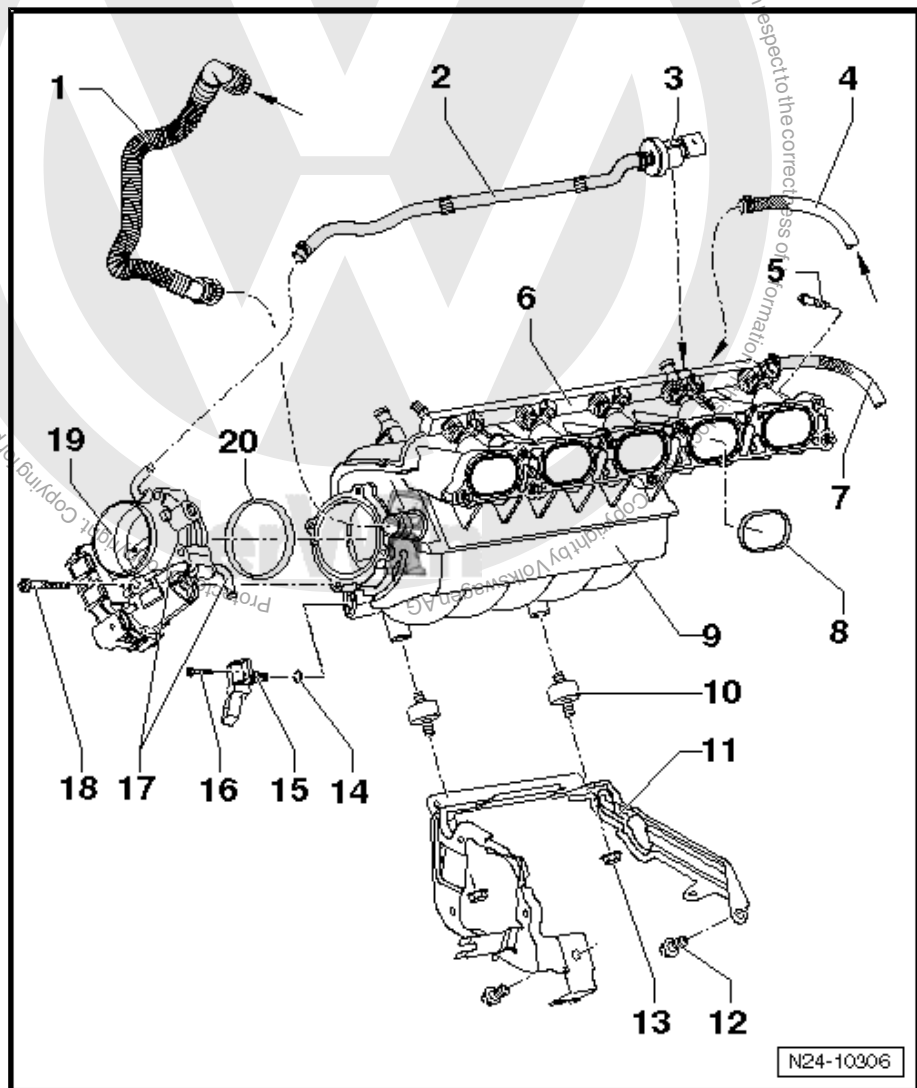



15 - Manifold Absolute Pressure Sensor - G71-

16 - Bolt

- 3.5 Nm

17 - Coolant Connections

- Phased-in introduction of a throttle valve control module without coolant heating.

18 - Bolt

- 6.5 Nm

19 - Throttle Valve Control Module - J338-

- With Epc Throttle Drive - G186- , EPC Throttle Drive Angle Sensor 1 - G187- and EPC Throttle Drive Angle Sensor 2 - G188- .
- When replacing, erase the adaptation values and adapt the Engine Control Module (ECM) to the throttle valve control module. Refer to "Guided Functions" in the vehicle diagnostic tester.

20 - Gasket

- Replace if damaged.

2.4 Fuel Rail and Injectors Overview

1 - Bolt

- 3.5 Nm

2 - Fuel Rail

3 - Fuel Supply Line

4 - O-Ring

- Always replace.
- Lubricate with clean engine oil.

5 - Retaining Clip

- Make sure clip is correctly seated on the fuel injector and fuel rail.

6 - Fuel Injector - N30, N31, N32, N33, N83-

- Removing and installing. Refer to ["5.4 Fuel Injectors", page 164](#) .

7 - Intake Manifold

8 - Cap

9 - Bleed Valve

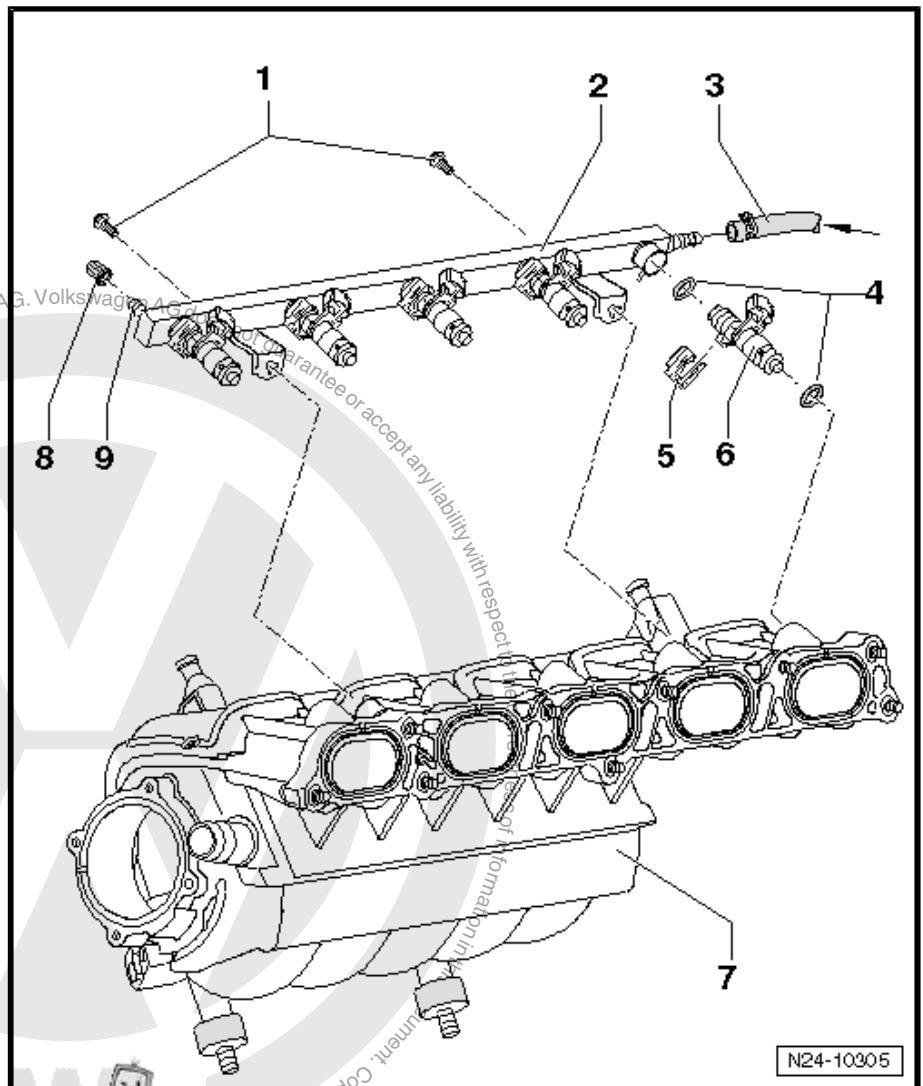

Protected by copyright. Copying for private or commercial purposes, in part or in whole, is not permitted. Copyright by Volkswagen AG.



2.5 Intake Manifold Overview

1 - Connecting Hose

- For crankcase ventilation.
- From the cylinder head cover.

2 - Ventilation Hose

3 - EVAP Canister Purge Regulator Valve 1 - N80-

4 - Vacuum Hose

- From the Leak Detection Pump - V144-
- Vehicle through MY 2009 only.
- From MY 10, the vacuum connection is on the vacuum line to the brake booster.

5 - Bolt

- 9 Nm

6 - Fuel Rail

- Overview. Refer to ["2.4 Fuel Rail and Injectors Overview", page 153](#).

7 - Fuel Supply Line

8 - Gasket

- Always replace.
- Note the installed position:

Casting mark points upward.

9 - Intake Manifold

- Removing and installing. Refer to ["5.3 Intake Manifold", page 161](#).

10 - Intake Manifold Support

- Not installed on all vehicles.

11 - Bolt

- 25 Nm

12 - Bolt

- 16 Nm

13 - O-Ring

- Replace if damaged.

14 - Manifold Absolute Pressure Sensor - G71-

- From MY 2009 with the Intake Air Temperature Sensor - G42-.

15 - Bolt

- 3.5 Nm

16 - Coolant Connections

- Phased-in introduction of a throttle valve control module without coolant heating.

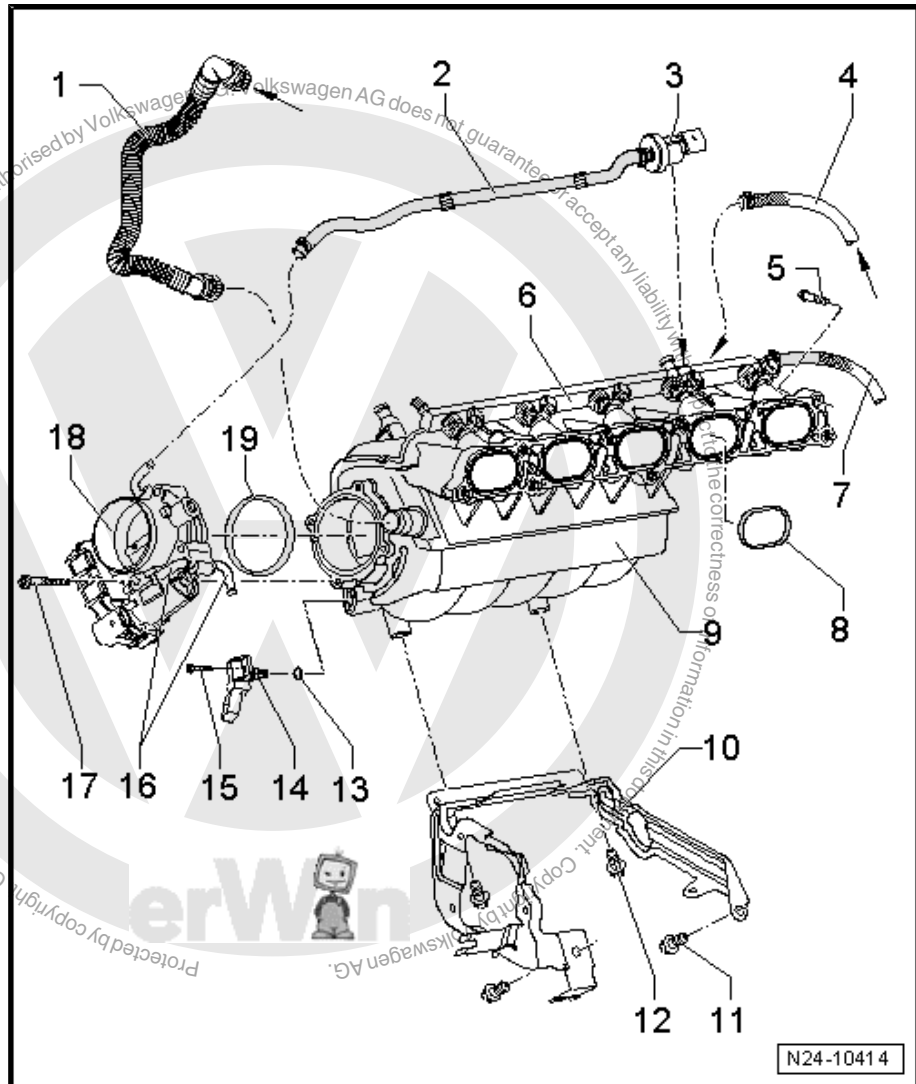



17 - Bolt

- 6.5 Nm

18 - Throttle Valve Control Module - J338-

- With EPC Throttle Drive - G186- , EPC Throttle Drive Angle Sensor 1 - G187- and EPC Throttle Drive Angle Sensor 2 - G188-
- When replacing, erase the adaptation values and adapt the Engine Control Module (ECM) to the throttle valve control module. Refer to "Guided Functions" in the vehicle diagnostic tester.

19 - Gasket

- Replace if damaged.

2.6 Fuel Rail and Injectors Overview

1 - Bolt

- 3.5 Nm

2 - Fuel Rail

3 - Fuel Supply Line

4 - O-Ring

- Always replace.
- Lubricate with clean engine oil.

5 - Retaining Clip

- Make sure the clip is correctly seated on the fuel injector and fuel rail.

6 - Fuel Injector - N30, N31, N32, N33, N83-

- Removing and installing. Refer to ["5.4 Fuel Injectors", page 164](#) .

7 - Intake Manifold

8 - Cap

9 - Bleed Valve

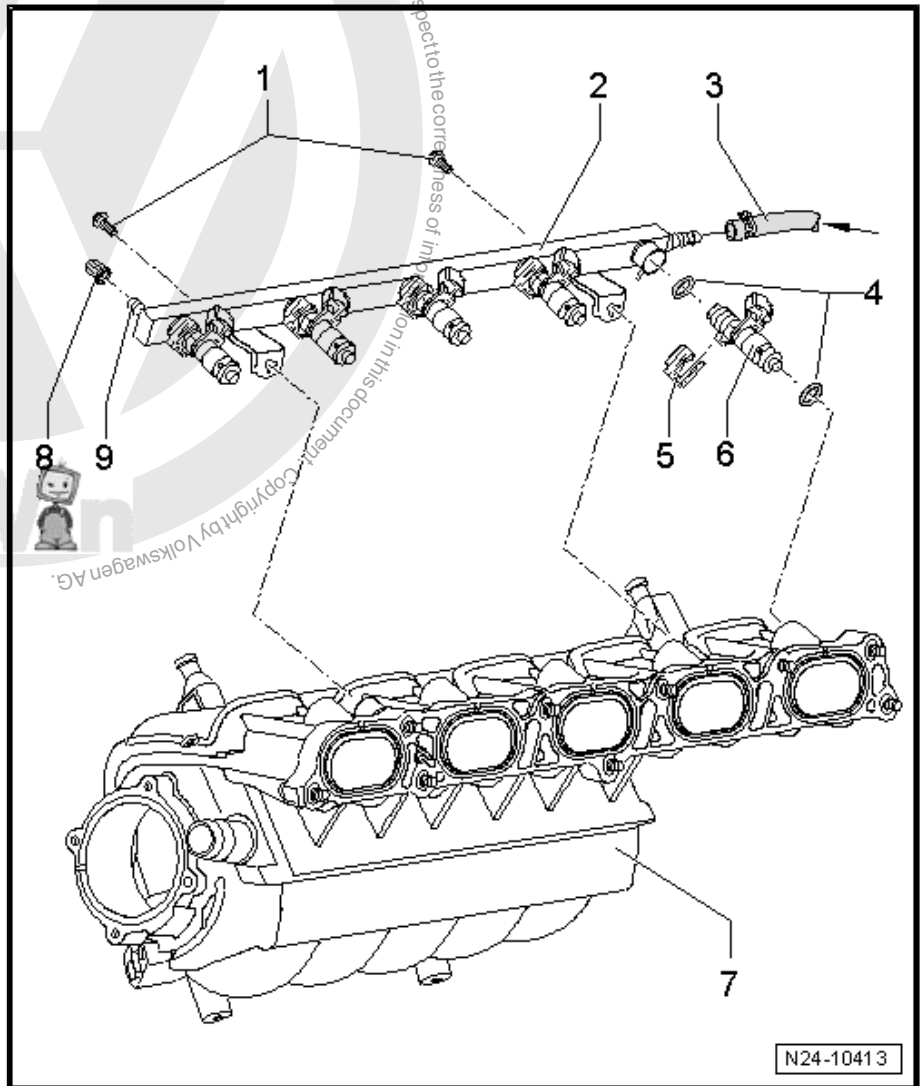



3 Specifications

⇒ **“3.1 Fastener Tightening Specifications”, page 156**

3.1 Fastener Tightening Specifications

Lower Air Filter Housing Bolt Tightening Sequence and Specification

- Tighten the bolts, in sequence -1 through 5- to 2 Nm.

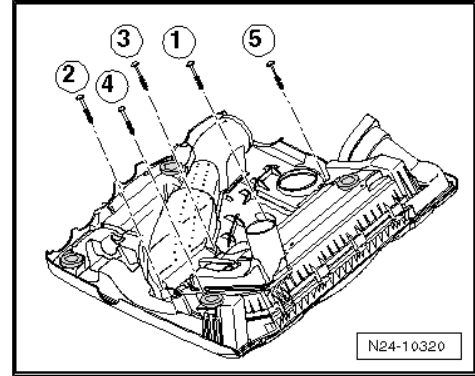



4 Diagnosis and Testing

⇒ ["4.1 Fuel Injector, Checking", page 157](#)

4.1 Fuel Injector, Checking

Special tools and workshop equipment required

- ◆ Remote Control - VAG1348/3A-
- ◆ Adapter Cable - VAG1348/3-2-
- ◆ Injector Rate Tester - VAG1602-
- ◆ Connector Test Set - VAG1594C-
- ◆ Test Instrument Adapter/DSO (5-pin) - VAS5565-

Checking for Leaks

- The fuel pressure must be OK. Refer to ⇒ Fuel Supply System; Rep. Gr. 20 ; Diagnosis and Testing .
 - Remove the fuel rail -2- with the fuel injectors installed. Refer to ⇒ ["5.4 Fuel Injectors", page 164](#) and place it on a clean cloth.
- Do not disconnect the battery and do not disconnect the fuel supply line at the quick acting coupling or at the fuel rail.
- The connectors must be disconnected from the fuel injectors.
 - Remove the rear seat bench. Refer to "Rear Seats" in ⇒ Body Interior; Rep. Gr. 72 ; Removal and Installation .

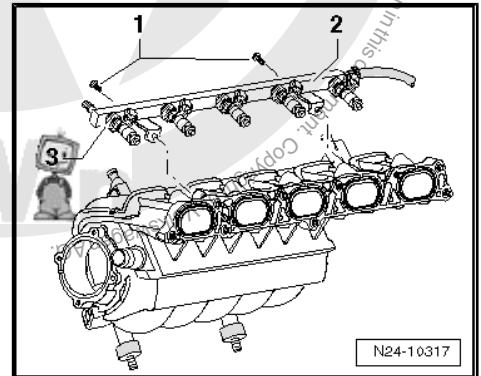

- Remove the cover from the fuel delivery unit.

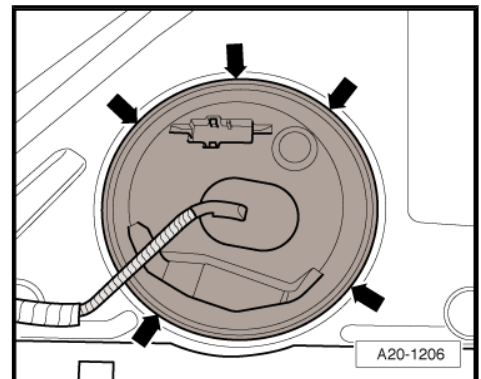

- First, pull on the connector -arrow- without pressing the retainer to make sure it is connected securely. If the connector was not connected correctly, it could cause a fault.
- Disconnect the connector.
- Check the contacts on the connector and the fuel delivery unit for damage.

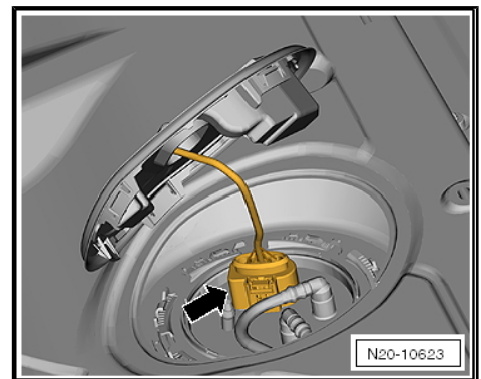



- Install the Test Instrument Adapter/DSO (5-pin) - VAS5565- between the connectors on the fuel delivery unit and cover.
- Connect the Remote Control - VAG1348/3A- to the Test Instrument Adapter/Dso (5-Pin) - VAS5565- and to battery positive (+).



Note

This step allows the fuel pump to run when the engine is not running.

- Operate the Remote Control - VAG1348/3A- and look for leaks in the fuel injectors. Only 1 to 2 drops per minute may emit from each injector when the fuel pump is running.

If the fuel loss is greater:

- Disconnect the connection to battery positive (+) and replace the leaking fuel injector. Refer to ⇒ ["5.4 Fuel Injectors", page 164](#) .

Checking the Injection Quantity

- The fuel pressure must be OK. Refer to ⇒ Fuel Supply System; Rep. Gr. 20 ; Diagnosis and Testing .
- The fuel rail is removed.
- The fuel injectors are installed in the fuel rail and the fuel line connected.
- The Remote Control - VAG1348/3A- is connected to the fuel delivery unit.
- Place a fuel injector to be tested into a graduated measuring glass from the Injector Rate Tester - VAG1602- .
- Using an adapter cable from the Connector Test Set - VAG1594C- , connect the cable to a terminal on the fuel injector to be checked and to engine ground (-).
- Using Adapter Cable - VAG1348/3-2- , connect it to the second terminal of the fuel injector and to the Remote Control - VAG1348/3 A- .
- Connect the alligator clip to battery positive (B+).
- Operate the Remote Control - VAG1348/3A- for 30 seconds.
- Repeat the check on the other injectors. Use new graduated measuring glasses for this.
- After all the fuel injectors have been activated, place the graduated measuring glasses on a level surface and compare the quantity of injected fuel.

Specified value: 85 to 105 ml (2.87 to 3.55 oz) per injector

While checking the injection quantity, the spray pattern should also be checked. The spray pattern must be the same for all the fuel injectors.

If the measured value of one or more fuel injectors is below or above the indicated specified value:

- Replace the faulty fuel injector. Refer to ⇒ ["5.4 Fuel Injectors", page 164](#) .

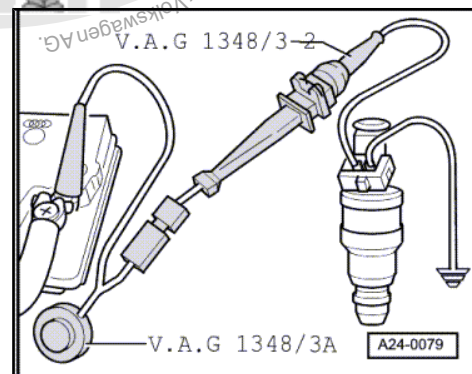
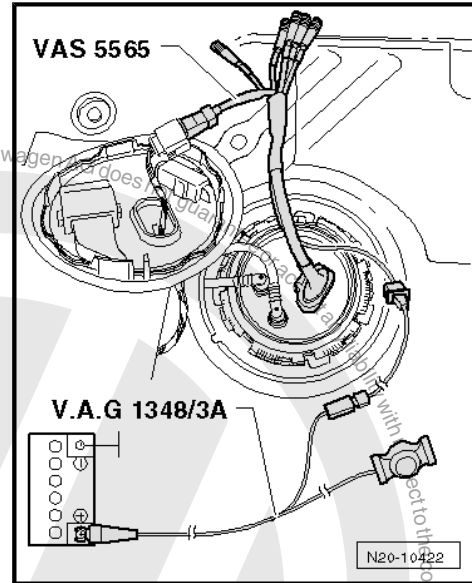



5 Removal and Installation

⇒ [“5.1 Engine Cover with Air Filter”, page 159](#)

⇒ [“5.2 Throttle Valve Control Module J338”, page 159](#)

⇒ [“5.3 Intake Manifold”, page 161](#)

⇒ [“5.4 Fuel Injectors”, page 164](#)

Rabbit, from MY 2006 through 2009

⇒ [“5.5 Engine Control Module, without Anti-Theft Protection”, page 166](#)

⇒ [“5.6 Engine Control Module, with Anti-Theft Protection”, page 167](#)

Golf, from MY 2010

⇒ [“5.7 Engine Control Module, without Anti-Theft Protection”, page 169](#)

⇒ [“5.8 Engine Control Module, with Anti-Theft Protection”, page 170](#)

5.1 Engine Cover with Air Filter

Removing

- Disconnect the connector -1-, if equipped, reposition the clamp -2- and disconnect the connecting pipe.
- Remove the screws -3- and disconnect intake air duct.

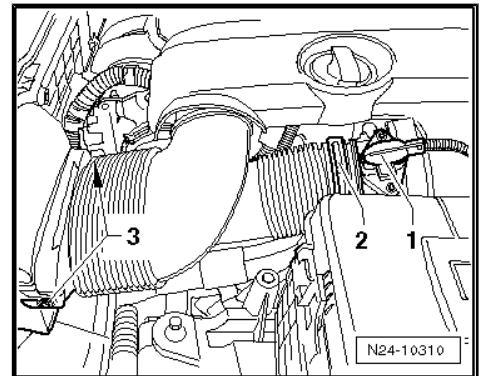

- Pull the engine cover up, with a jerking motion off of the mounts, first at the front in direction of -arrow 1-, then at the right rear in direction of -arrow 2- and finally at the left rear in direction of -arrow 3-.
- Carefully swivel the engine cover out of the rear area.

Installing



Note

The rubber bushings must not be treated with lubricant, neither for assembly to the cover or for assembly to the engine.

- Position the engine cover correctly on the mounts and press down by hand.

The rest of the installation follows the reverse of the removal procedure.

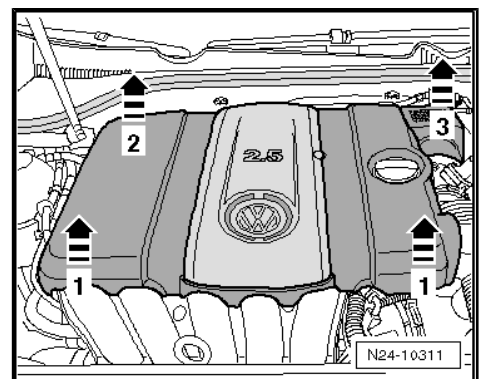

5.2 Throttle Valve Control Module - J338-

Special tools and workshop equipment required

- ◆ Hose Clamps up to 25 mm - 3094-



Removing



Note

Pay attention to the rules of cleanliness. Refer to
⇒ ["1.2 Clean Working Conditions", page 3](#) .

- Remove the engine cover with air filter. Refer to
⇒ ["5.1 Engine Cover with Air Filter", page 159](#) .
- Remove the connecting pipe -4-. To do so, disconnect the
Secondary Air Injection (AIR) connecting pipe -1-, if equipped,
and the vent tube -2- and reposition the spring clamp -3-.

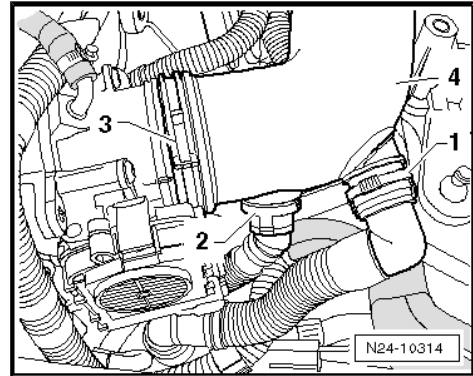

- Disconnect the connector -1- and the vent hose -2-.
- Remove the bolts -arrows-.



Note

Seal the intake passage in the intake manifold using a clean cloth.

- Clamp off the coolant hoses using Hose Clamps Up to 25 mm
dia. - 3094- and disconnect them from the throttle valve control
module connections -arrows-, if equipped.

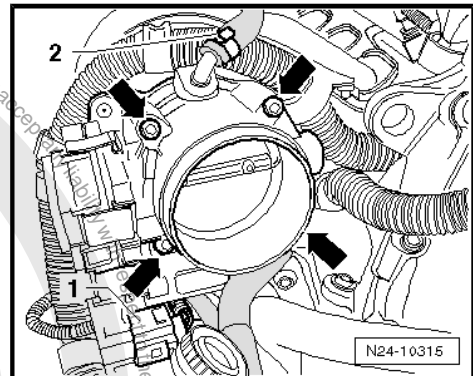

Installing

Install in reverse order of removal. Note the following:

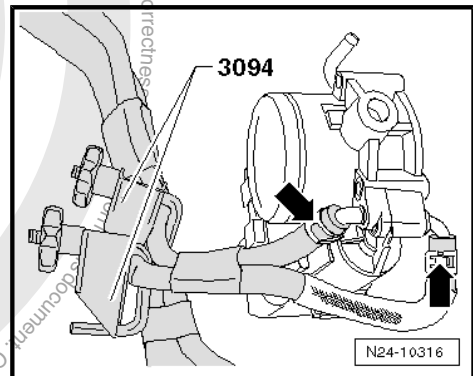



- ◆ Replace the gasket for the throttle valve control module, if damaged.
- ◆ Connection for coolant hoses.
- ◆ Make sure the connecting pipe -1-, if equipped and the vent tube -2- are fitted securely.
- ◆ When replacing, erase the adaptation values and adapt the Engine Control Module (ECM) to the throttle valve control module. Refer to "Guided Functions" in the vehicle diagnostic tester.

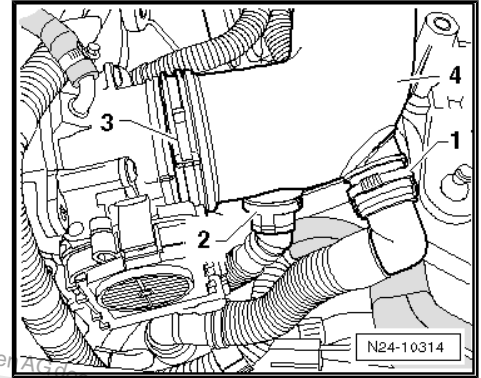

Tightening Specifications

Component	Nm
Throttle valve control module to intake manifold	6.5

5.3 Intake Manifold

Special tools and workshop equipment required

- ◆ Torque Wrench (5-50 Nm)- VAG1331-
- ◆ Socket and Extended Bit- T10107A-

Removing



Note

- ◆ *Observe the safety precautions. Refer to ⇒ "1.1 Safety Precautions", page 1 .*
- ◆ *Follow the guidelines for clean working conditions. Refer to ⇒ "1.2 Clean Working Conditions", page 3 .*
- See if a coded radio is installed. If so, obtain the anti-theft code.
- Disconnect the battery. Refer to ⇒ Electrical Equipment; Rep. Gr. 27 ; Removal and Installation .
- Remove the engine cover with air filter. Refer to ⇒ "5.1 Engine Cover with Air Filter", page 159 .



WARNING

- ◆ *The fuel supply line is under pressure. Always wear protective eyewear and protective clothing to prevent injuries and fuel from coming in contact with your skin. Before loosening the fuel lines, place a cloth around the connection point. Remove the hose connection carefully to release the pressure.*

- Disconnect the vent line -1-, the vacuum line -2- and the fuel supply line -3-. To release the lines -1 and 2- , press the circlip in. With the line -3-, the retainer must be pressed upward into the housing.

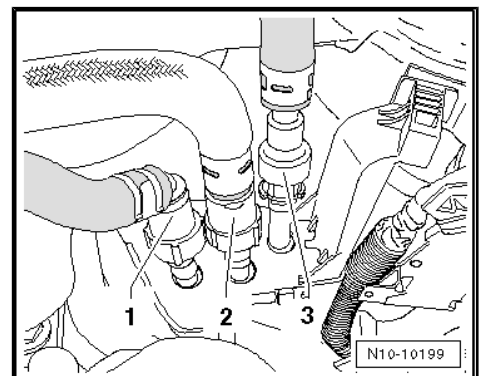



- Disconnect the connectors -1, 2 and 6-
- Remove the wiring harness -3- from the transport strap.
- Pull the clips -4- and retaining ring -5- out of the locking mechanism.
- Remove the bolts -7- and remove the transport strap.
- Remove the Throttle Valve Control Module - J338- . Refer to ⇒ ["5.2 Throttle Valve Control Module J338"](#), page 159 . The coolant hoses remain attached, if equipped.
- Disconnect the Manifold Absolute Pressure Sensor - G71- connector.
- Disconnect the connector -1- and crankcase ventilation hose -3-.
- Remove the wiring harness -2-. To do so, carefully pry out the clips -arrows-

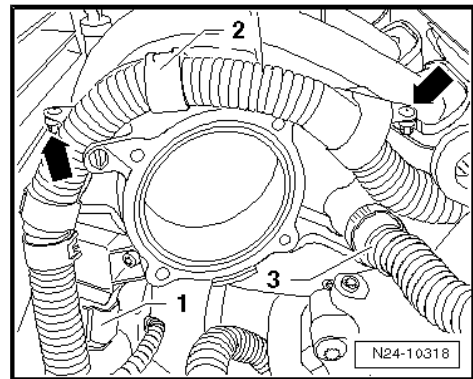
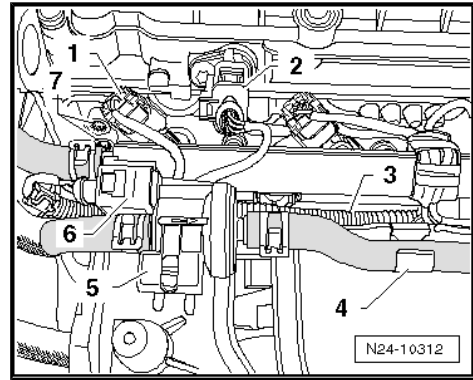

- Pull the oil dipstick out -1- and press the retaining ring -4- downward.
- Remove the noise insulation. Refer to ⇒ Body Exterior, Rep. Gr. 50 ; Description and Operation .

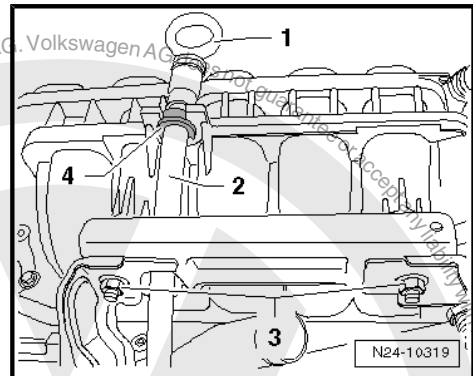

- Loosen the bolts or nuts -1- on the bottom side of the intake manifold.

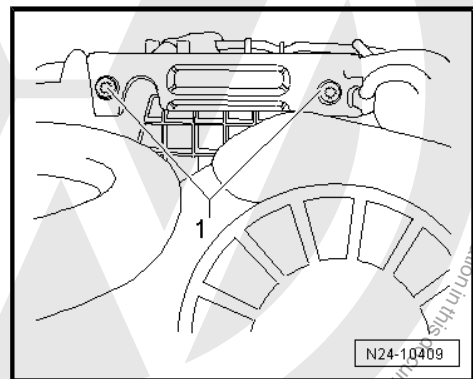

Protected by copyright. Copying for private or commercial purposes, in part or in whole, is not permitted unless authorised by Volkswagen AG. Copyright by Volkswagen AG. Information in this document. Copyright by Volkswagen AG.



- Loosen the bolt -arrow- for the intake manifold support and guide pipe.

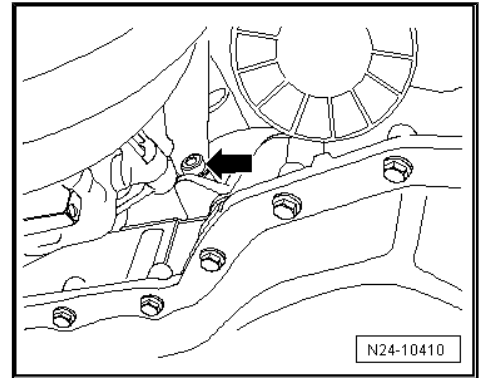

- Lay the guide pipe -arrows- aside.

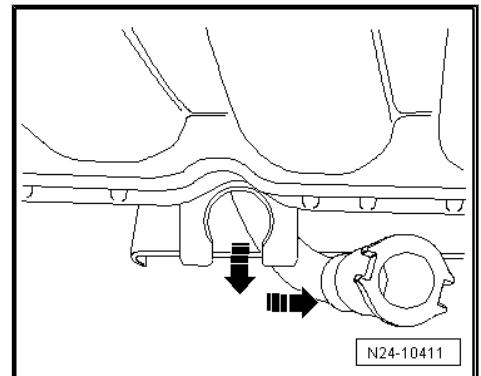

- Open the clip -arrow- on the Leak Detection Pump - V144- vacuum hose.
- Loosen the intake manifold bolts -arrows- using the Socket And Extended Bit - T10107A- .

The bolts remain in the intake manifold.

- Remove the intake manifold upward at an angle.
- Seal the intake passages in the cylinder head using a clean cloth.

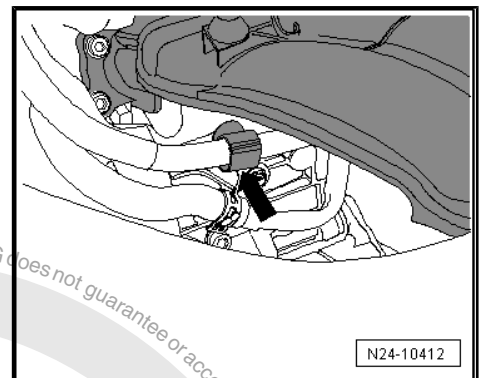

If the manifold must be replaced

- Remove the fuel rail with injectors. Refer to ["5.4 Fuel Injectors", page 164](#) .
- Disconnect the vacuum hose for the leak detection pump.

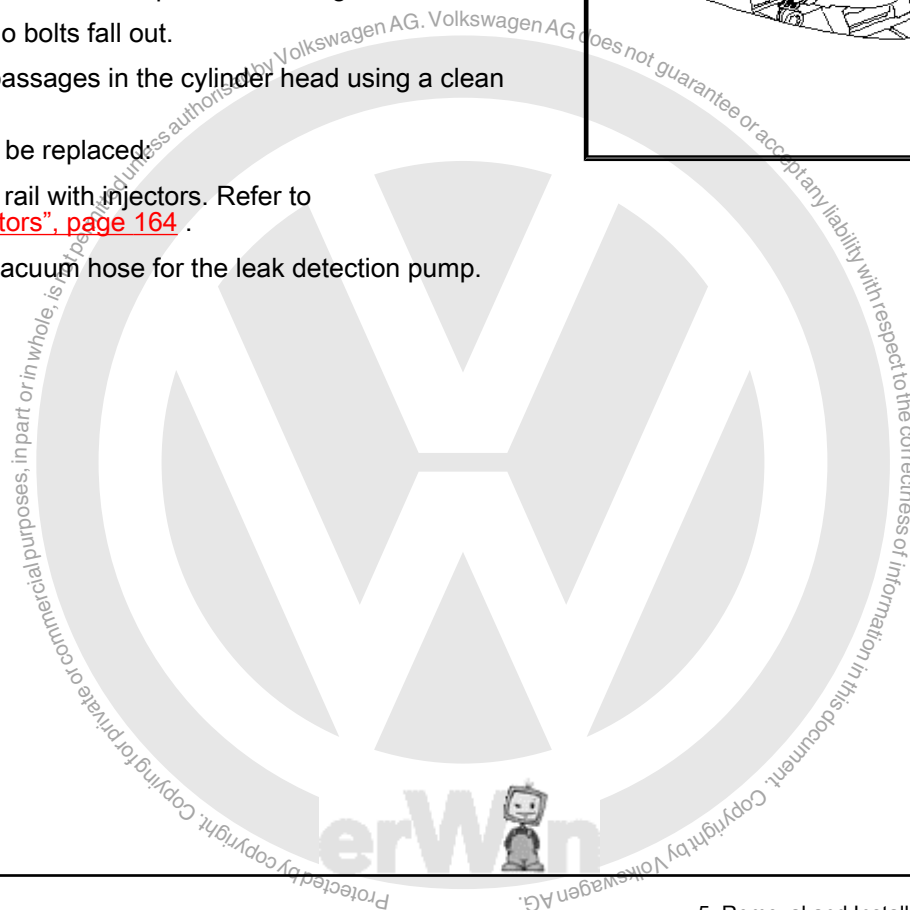



- Remove the Manifold Absolute Pressure (MAP) sensor.

Installing

Install in reverse order of removal. Note the following:

- ◆ Replace the seals between the intake manifold and cylinder head.
- ◆ Replace the oil dipstick guide tube seal.
- ◆ Tighten the bolts for the intake manifold starting inside and working toward the outside in a diagonal sequence.
- Connect the battery. Refer to ⇒ Electrical Equipment; Rep. Gr. 27 ; Removal and Installation .
- Bleed the fuel supply system. Refer to ⇒ [“1.1 Fuel System, Filling and Bleeding”, page 144](#) .

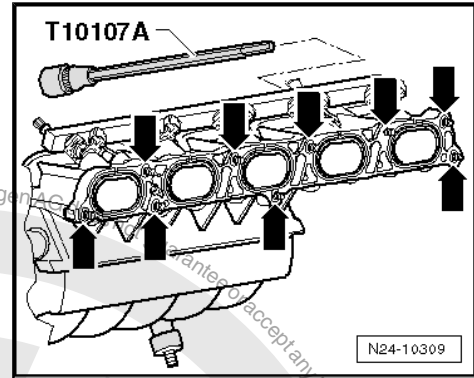

Tightening Specifications

Component	Nm
Intake manifold to cylinder head	9
Intake manifold support to intake manifold, engine codes BGP and BGQ	20
Intake manifold support to intake manifold, engine codes CBTA and CBUA	16
Intake manifold support to cylinder block	25
Transport strap to cylinder head	25
Oil dipstick guide tube to cylinder block	25
MAP sensor to intake manifold	3.5

5.4 Fuel Injectors

Removing



Note

- ◆ *Observe the safety precautions. Refer to ⇒ [“1.1 Safety Precautions”, page 1](#) .*
- ◆ *Follow the guidelines for clean working conditions. Refer to ⇒ [“1.2 Clean Working Conditions”, page 3](#) .*
- See if a coded radio is installed. If so, obtain the anti-theft code.
- Disconnect the battery. Refer to ⇒ Electrical Equipment; Rep. Gr. 27 ; Removal and Installation .
- Remove the engine cover with air filter. Refer to ⇒ [“5.1 Engine Cover with Air Filter”, page 159](#) .



WARNING

- ◆ *The fuel supply line is under pressure. Always wear protective eyewear and protective clothing to prevent injuries and fuel from coming in contact with your skin. Before loosening the fuel lines, place a cloth around the connection point. Remove the hose connection carefully to release the pressure.*



- Disconnect the vent line -1- and the fuel supply line -3-. To release the line -1-, press the circlip in. With line -3-, the retainer must be pressed upward into the housing.

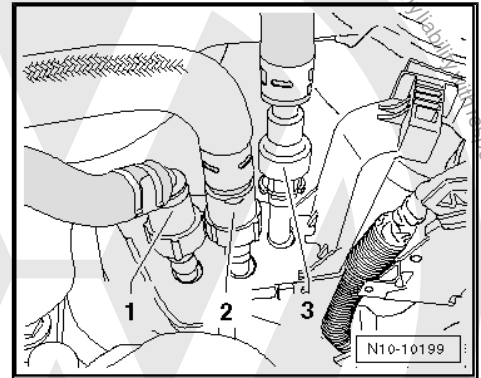

- Disconnect the connectors -1, 2 and 6-.
- Remove the wiring harness -3- from the transport strap.
- Pull the clip -4- and retaining ring -5- out of the locking mechanism.
- Remove the bolts -7- and remove the transport strap.
- Remove the bolts -1- and pull the fuel rail with the injectors evenly out of the intake manifold.
- Seal or cover the openings in the intake manifold.

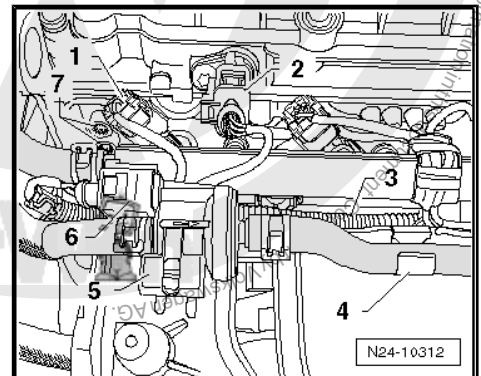

- Pull off the retaining clips -3- and then the fuel injectors.

Installing

- Install new O-rings for the fuel injectors and coat them lightly with clean engine oil.

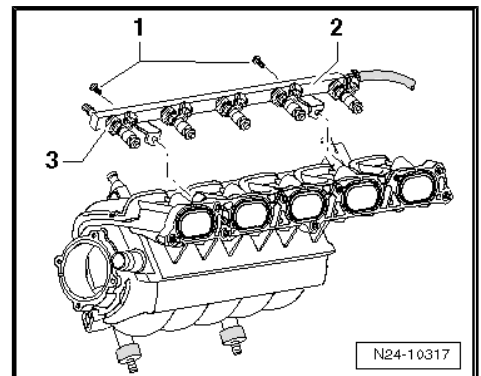



- Press the fuel injectors into the fuel rail so that the tabs -1 and 2- align.
- Slide the retaining clip -3- as shown into the groove in the fuel injector. The collar -4- must be located correctly in the cutout of the retaining clip on both sides.
- After assembling, check all the fuel injectors for correct fitting.
- Attach the fuel rail with secured fuel injectors onto the intake manifold and press it in uniformly.
- Bolt the fuel rail to the intake manifold.

The rest of the installation follows the reverse of the removal procedure. Note the following:

- Connect the battery. Refer to ⇒ Electrical Equipment; Rep. Gr. 27 ; Removal and Installation
- Bleed the fuel supply system. Refer to ⇒ ["1.1 Fuel System, Filling and Bleeding", page 144](#) .

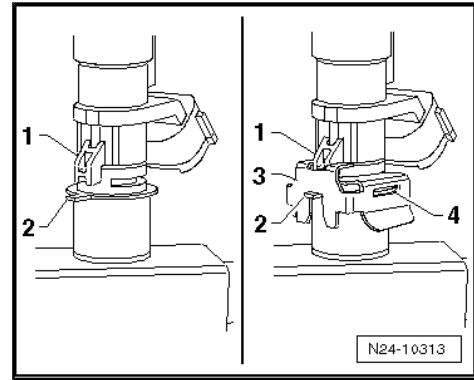

Tightening Specifications

Component	Nm
Fuel rail to intake manifold	3.5

5.5 Engine Control Module, without Anti-Theft Protection



Note

If the Engine Control Module (ECM) will be replaced, connect the vehicle diagnostic tester and perform the "Replacing Engine Control Module" guided function.

Removing

- Turn off the ignition.
- Remove the wiper arms and plenum chamber cover. Refer to ⇒ Electrical Equipment; Rep. Gr. 92 ; Removal and Installation .
- Remove the plenum chamber bulkhead. Refer to ⇒ Body Exterior; Rep. Gr. 50 ; Description and Operation .
- Disconnect the front connector -1- from the ECM.
- Pry up the locking mechanism -2- slightly.
- Then slide the ECM out of the retainer -arrow-.
- Disconnect the rear connector from the ECM.

Installing

- Connect and lock the rear connector to the ECM.
- Slide the ECM onto the retaining plate.
- Connect and lock the front connector to the ECM.
- Install the plenum chamber bulkhead. Refer to ⇒ Body Exterior; Rep. Gr. 50 ; Description and Operation .
- Install the plenum chamber cover and the wiper arms. Refer to ⇒ Electrical Equipment; Rep. Gr. 92 ; Removal and Installation .

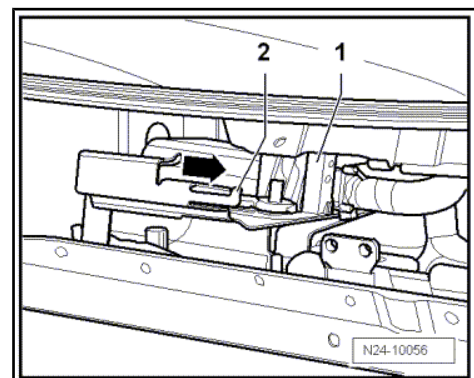



5.6 Engine Control Module. with Anti-Theft Protection

Special tools and workshop equipment required

- ◆ Locking Pliers
- ◆ Window Cutter - VAG1561A-
- ◆ Saw Set - VAG1561/14-
- ◆ Heat Gun - VAS1978/14A-



Note

If the Engine Control Module (ECM) will be replaced, connect the vehicle diagnostic tester and perform the "Replacing Engine Control Module" guided function.

Removing

- Turn off the ignition.
- Remove the wiper arms and plenum chamber cover. Refer to ⇒ Electrical Equipment; Rep. Gr. 92 ; Removal and Installation .
- Remove the plenum chamber bulkhead. Refer to ⇒ Body Exterior; Rep. Gr. 50 ; Description and Operation .



Note

The threads of the shear bolts are equipped with locking compound. By heating the shear bolts using a hot air gun, the inhibition effect of the locking compound is lowered.



Caution

Cover the wires, connectors and control modules near the ECM to prevent them from being burned.

Perform the adjustments on the hot air gun -4- as shown:

- Turn the potentiometer for temperature adjustment -2- to maximum heat output (600 °C (1112 °F)).
- Move the two stage switch for air quantity -3- to position 3.



WARNING

By heating the shear bolts, parts of the protective housing are heated intensely. Wear protective gloves to prevent injuries.

- Guide the nozzle of the hot air gun onto the shear bolts.
- Turn the heat gun on and heat the bolts.
- Remove the bolts using locking pliers.

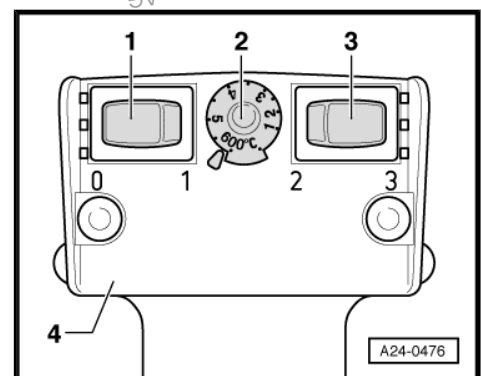



Note

If the bolts cannot be removed, cut into the head so two parallel lines are formed -arrows- and then remove them.

- Insert a screwdriver -A- between the protective housing and retaining plate -arrow-.

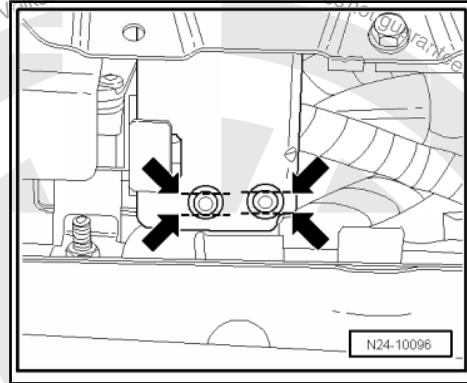

- Pry the protective housing upward using the screwdriver -A- and pull it off sideways from the retaining plate -arrow-.
- Disconnect the front connector -1- from the ECM.
- Pry up the locking mechanism -2- slightly.
- Then slide the ECM out of the retainer -arrow-.

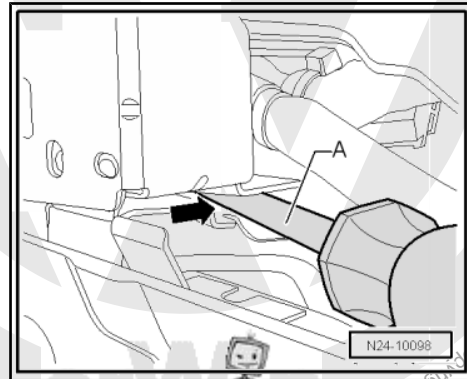

- Disconnect the rear connector from the ECM.

Installing

- Connect and lock the rear connector to the ECM.
- Slide the ECM onto the retaining plate.
- Connect and lock the front connector to the ECM.
- Slide the protective housing onto the retaining plate.

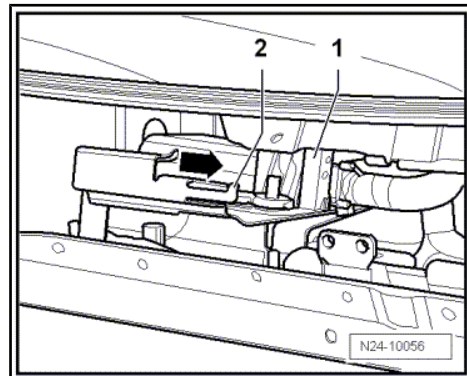
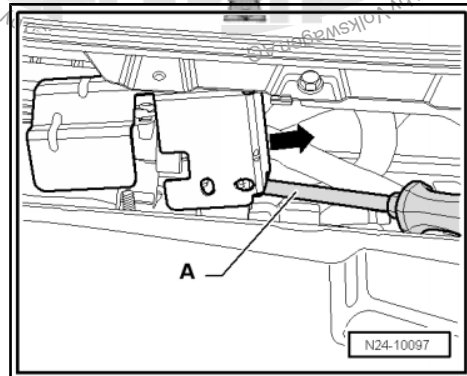



- Tighten the shear bolts -1- uniformly until the bolt heads shear off.
- Install the plenum chamber bulkhead. Refer to ⇒ Body Exterior; Rep. Gr. 50 ; Description and Operation .
- Install the plenum chamber cover and the wiper arms. Refer to ⇒ Electrical Equipment; Rep. Gr. 92 ; Removal and Installation .

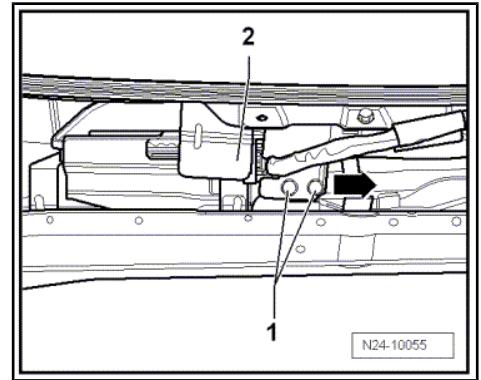

5.7 Engine Control Module, without Anti-Theft Protection



Note

If the Engine Control Module (ECM) will be replaced, connect the vehicle diagnostic tester and perform the "Replacing Engine Control Module" guided function.

Removing

- Turn off the ignition.
- Remove the wiper arms and plenum chamber cover. Refer to ⇒ Electrical Equipment; Rep. Gr. 92 ; Removal and Installation .
- Remove the plenum chamber bulkhead. Refer to ⇒ Body Exterior; Rep. Gr. 50 ; Description and Operation .
- Push the retaining frame in the direction of the -arrow- downward and remove the ECM.

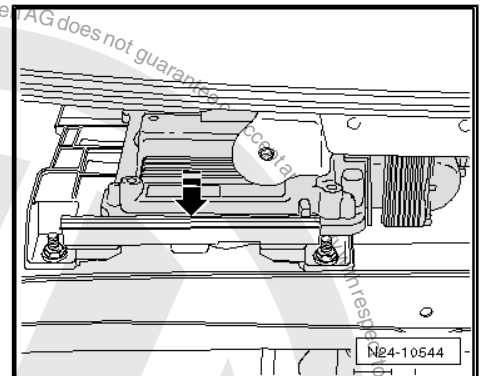

- Push the retainers in the direction of the -arrow- and disconnect the connector.

Installing

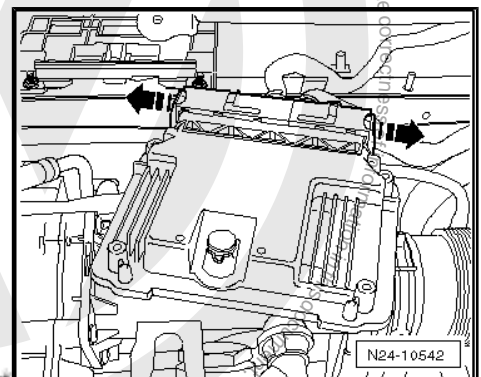



- Connect the connector to the ECM and push the retainers all the way in, in the direction of the -arrow-.

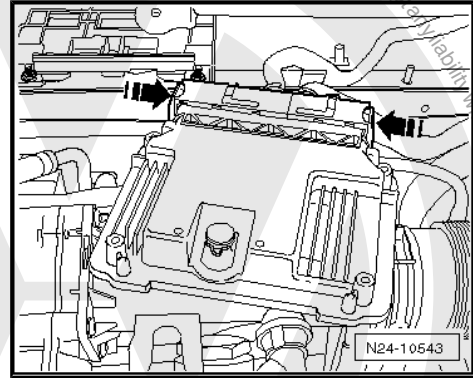

- Mount the ECM into the retaining frame and push it in, in the direction of the -arrow- upward.
- Install the plenum chamber bulkhead. Refer to => Body Exterior; Rep. Gr. 50 ; Description and Operation .
- Install the plenum chamber cover and the wiper arms. Refer to => Electrical Equipment; Rep. Gr. 92 ; Removal and Installation .

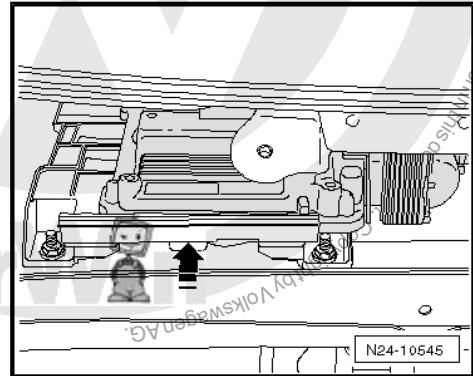

5.8 Engine Control Module, with Anti-Theft Protection



Note

- ◆ *If the Engine Control Module (ECM) will be replaced, connect the vehicle diagnostic tester and perform the "Replacing Engine Control Module" guided function.*
- ◆ *The threads on the shear bolts may have locking compound on them. Heat the shear bolts using the Hot Air Gun - VAS1978/14- so they are easier to remove. When doing this be careful not to damage any wires, connectors or components nearby.*

Removing

- Turn off the ignition.
- Remove the wiper arms and plenum chamber cover. Refer to => Electrical Equipment; Rep. Gr. 92 ; Removal and Installation .
- Remove the plenum chamber bulkhead. Refer to => Body Exterior; Rep. Gr. 50 ; Description and Operation .



- Push the retaining frame in the direction of the -arrow- downward and remove the ECM.

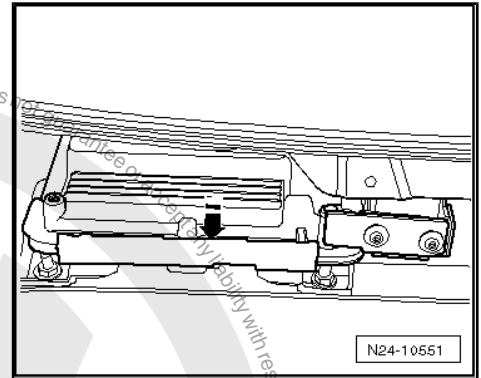

- Remove the shear bolts -arrows-.

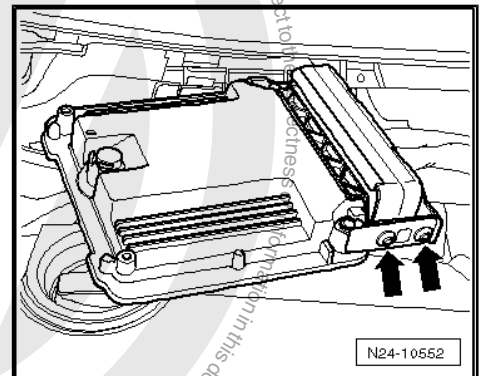

- Slide a screwdriver between both locking plates in direction of -arrow-.
- Carefully push the screwdriver -arrow- in and at the same time bend the locking bracket -1- upward.

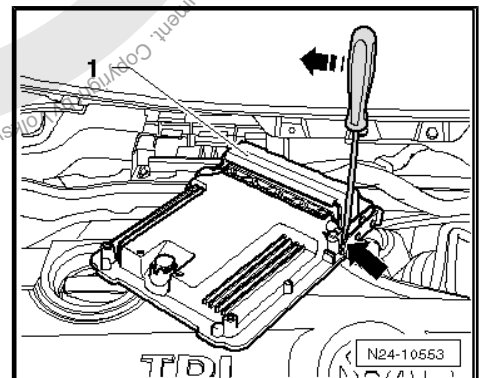

- Bend the locking bracket -1- in the direction of the -arrow- until it can be removed from the connectors.

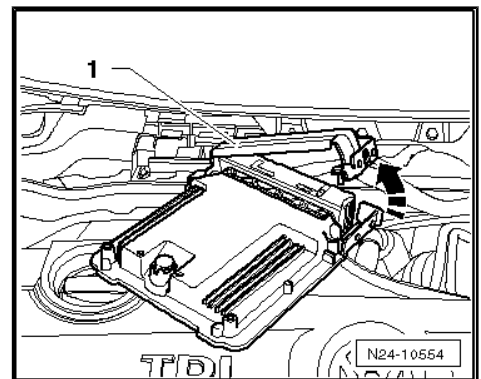



- Push the retainers in the direction of the -arrow- and disconnect the connector.

Installing

- Connect the connector to the ECM and push the retainers all the way in, in the direction of the -arrow-.

- Place the locking bracket -1- on the connectors and press it in, in the direction of the -arrow-.
- Install the bolts -2- all the way into the hole on the ECM housing.

- Secure the locking bracket to the ECM -arrows- with new shear bolts.
- Tighten the shear bolts -arrows- evenly until the bolt heads break off .

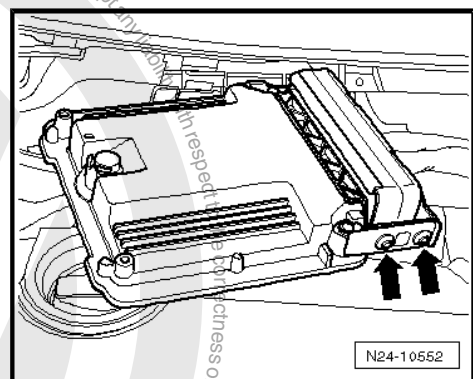
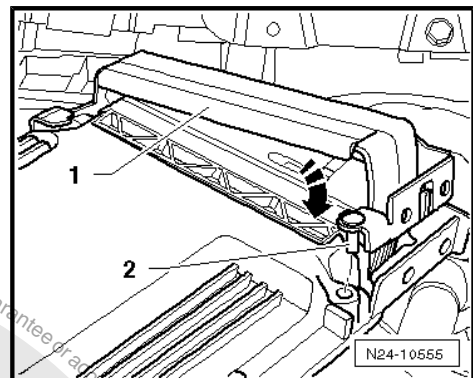
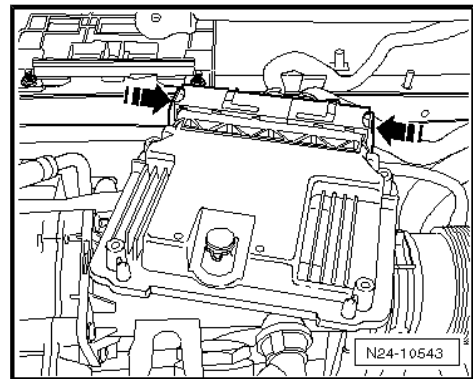
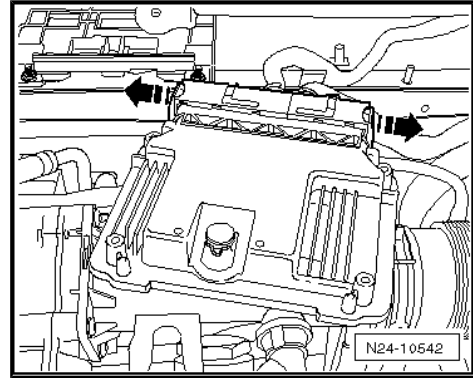



- Mount the ECM into the retaining frame and push it in, in the direction of the -arrow- upward.
- Install the plenum chamber bulkhead. Refer to ⇒ Body Exterior; Rep. Gr. 50 ; Description and Operation .
- Install the plenum chamber cover and the wiper arms. Refer to ⇒ Electrical Equipment; Rep. Gr. 92 ; Removal and Installation .

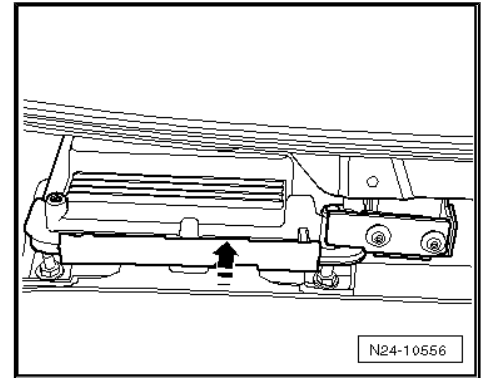



6 Special Tools

Special tools and workshop equipment required

- ◆ Window Cutter - VAG1561A-
- ◆ Suction Pump - VAS5226-
- ◆ Vehicle Diagnostic, Testing, and Information System - VAS5051B-

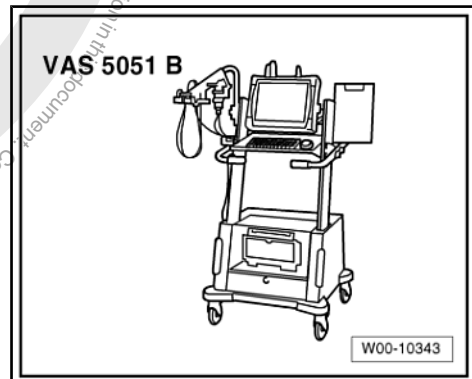
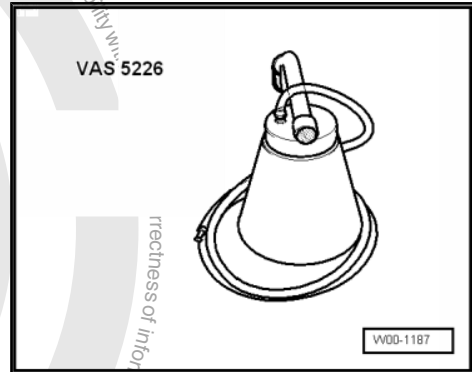

- ◆ Hose Clamps up to 25 mm Dia. - 3094-

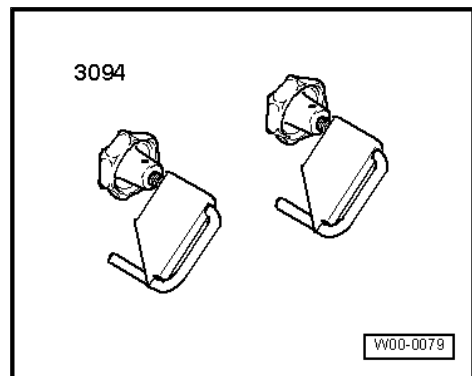

- ◆ Torque Wrench (5-50 Nm) - VAG1331-

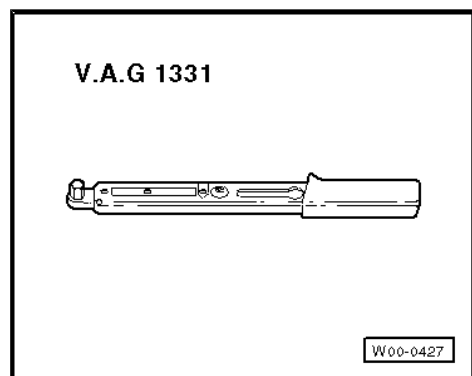



- ◆ Socket and Extended Bit - T10107A-

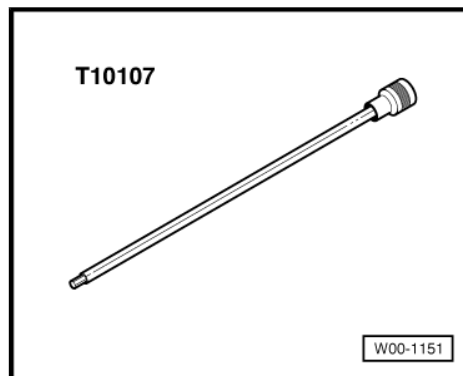

- ◆ Saw Set - VAG1561/14-

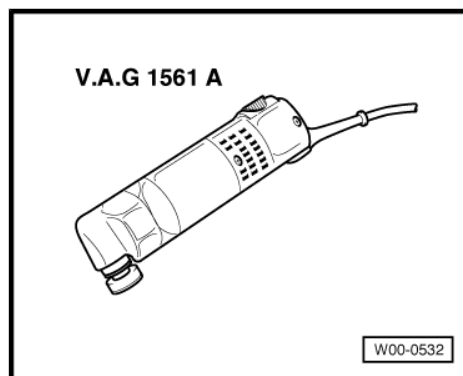

- ◆ Heat Gun - VAS1978/14A-

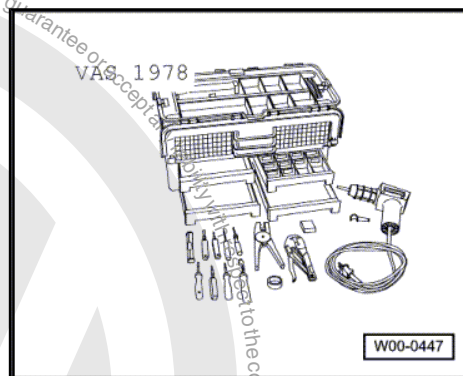



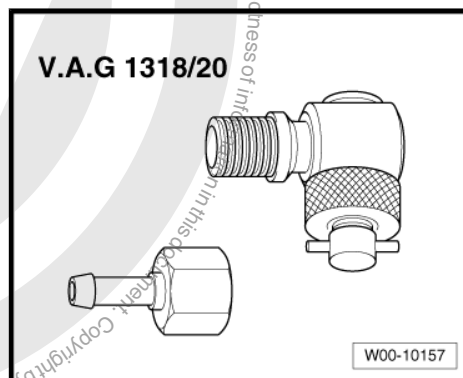

- ◆ Adapter for K-jetronic Test Device - VAG1318/20-



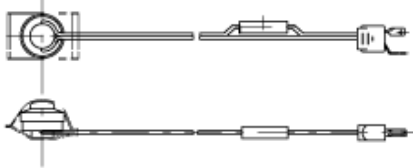

- ◆ Remote Control - VAG1348/3A-
- ◆ Adapter Cable - VAG1348/3-2-
- ◆ Injector Rate Tester - VAG1602-
- ◆ Connector Test Set - VAG1594C-
- ◆ Test Instrument Adapter/ DSO (5-pin) - VAS5565-

<p>V.A.G 1348/3</p> 	<p>V.A.G 1348/3-2</p> 
<p>V.A.G 1602</p> 	<p>V.A.G 1594 C</p> 
<p>W24-10005</p>	

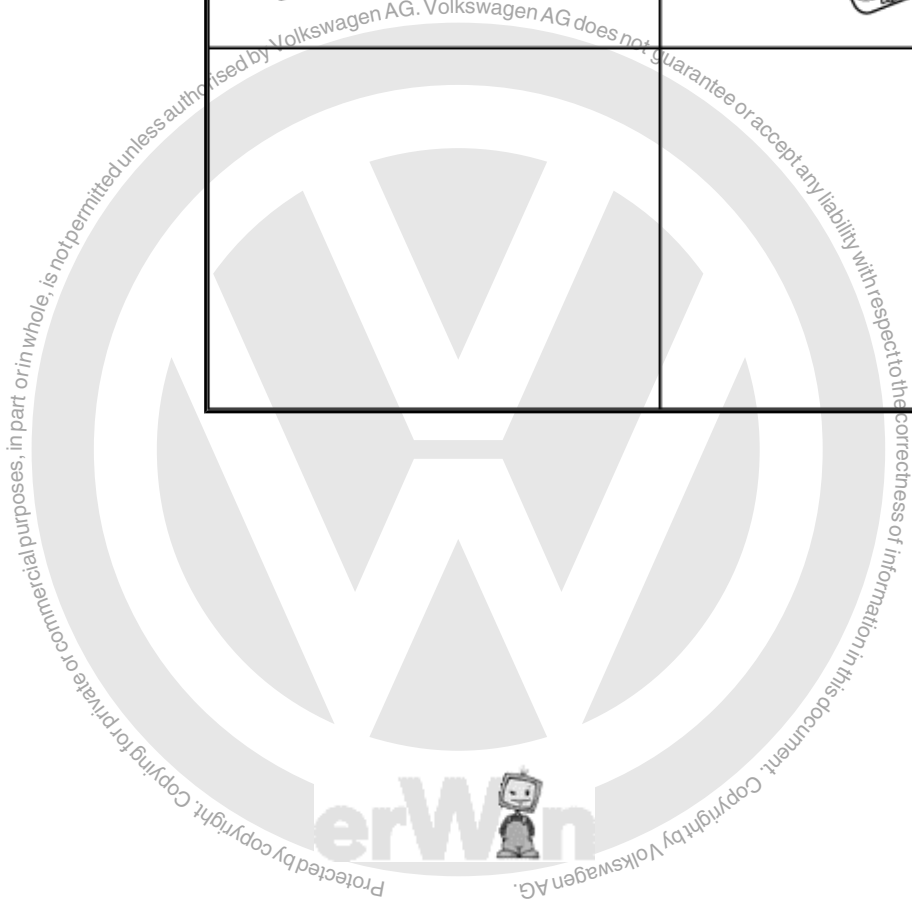



26 – Exhaust System, Emission Controls

1 Description and Operation

⇒ [“1.1 Secondary Air Injection System Overview”, page 177](#)

⇒ [“1.2 Exhaust Manifold Overview”, page 179](#)

Engine Codes BGP and CBTA

⇒ [“1.3 Exhaust Pipe with Catalytic Converter Overview”, page 180](#)

Engine Codes BGQ and CBUA

⇒ [“1.4 Exhaust Pipe with Catalytic Converter Overview”, page 182](#)

⇒ [“1.5 Muffler Overview”, page 184](#)

1.1 Secondary Air Injection System Overview



Note

The Secondary Air Injection (AIR) system is not installed on all engines.



1 - Bolt

- 10 Nm

2 - Secondary Air Injection (AIR) Pipe

- Follow the tightening sequence. Refer to ⇒ [Fig. "AIR Pipe Bolt Tightening Sequence"](#), page 179 .

3 - Connector

- For the AIR solenoid valve.

4 - Secondary Air Injection Solenoid Valve - N112-

- Do not disassemble.
- Checking. Refer to ⇒ ["3.1 Secondary Air Injection Solenoid Valve, Checking"](#), page 186 .
- Removing and installing. Refer to ⇒ ["4.2 Secondary Air Injection Solenoid Valve N112"](#), page 188 .

5 - Connecting Pipe

- Make sure it is secure
- To disengage, squeeze together the securing ring.

6 - Secondary Air Injection Sensor 1 - G609-

- Installed from MY 2009.

7 - Bolt

- 2 Nm
- Installed from MY 2009.

8 - Bracket

9 - Gasket

- Allocation. Refer to the Parts Catalog.

10 - Bolt

- 10 Nm

11 - Connecting Pipe

- For the AIR pump.

12 - Secondary Air Injection Pump Motor - V101-

- Removing and installing. Refer to ⇒ ["4.1 Secondary Air Injection Pump Motor V101"](#), page 187 .

13 - Rubber Bushing

14 - Bolt

- 25 Nm

15 - Nut

- 10 Nm

16 - Intake Manifold Support

- With the mounts for the AIR pump motor.

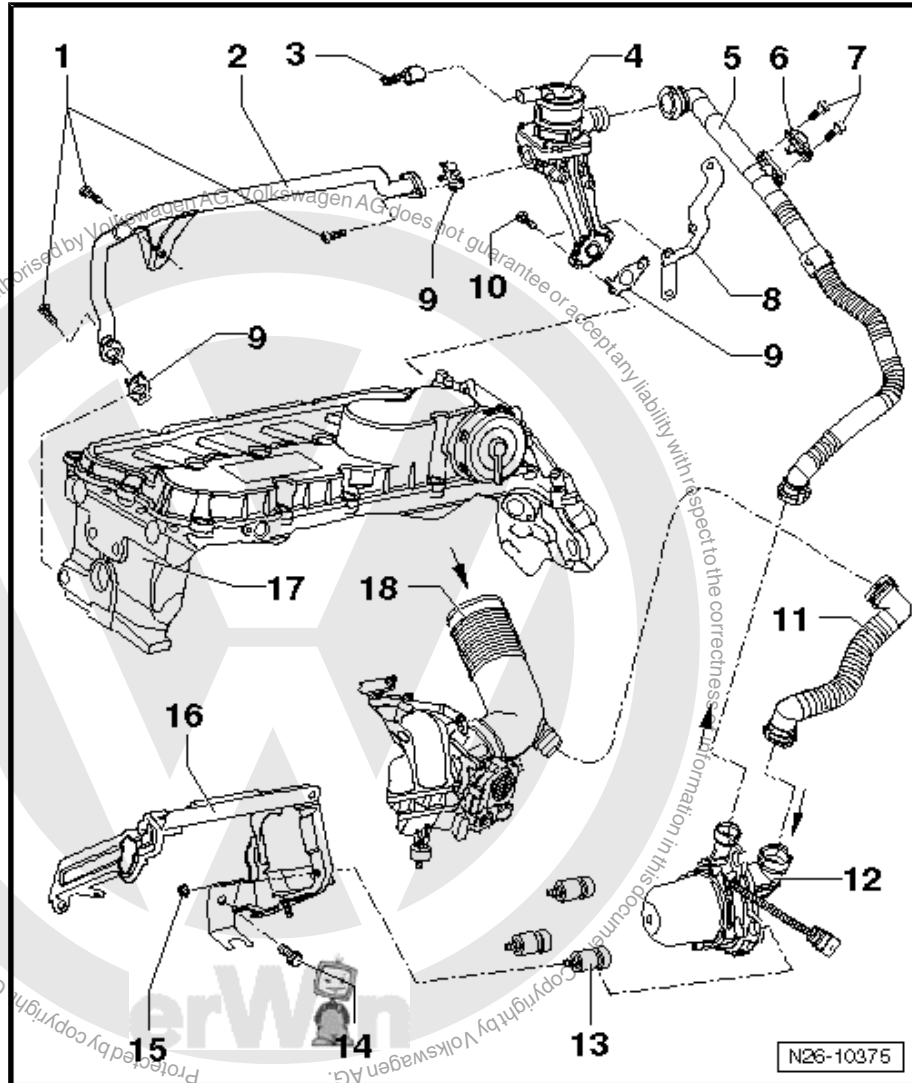

N26-10375



17 - Cylinder Head
18 - Connecting Pipe

AIR Pipe Bolt Tightening Sequence

- Replace all AIR pipe gaskets -A-.
- Install all bolts only hand tight.
- Tighten the bolts -1- first, then the bolt -2- and then the bolt -3- to 10 Nm.

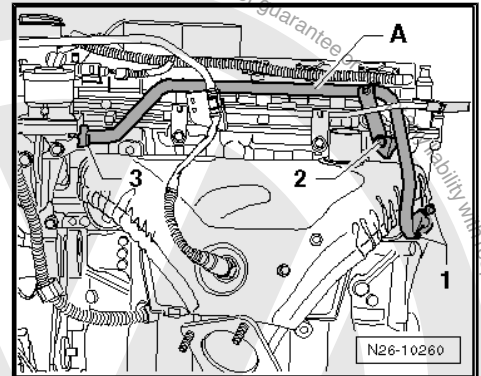

1.2 Exhaust Manifold Overview

1 - Gasket

- Always replace.

2 - Nut

- 25 Nm
- Always replace.

3 - Exhaust Manifold

- Coat the stud bolts on the cylinder head with hot bolt paste.
- Remove upward.

4 - Clip

5 - Heat Shield

6 - Bolt

- 10 Nm

7 - Heated Oxygen Sensor - G39-

- 55 Nm
- Use the Ring Spanner 7-Piece Set - 3337- for removal and installation.
- When reusing an old oxygen sensor again, only use hot bolt paste to grease the threads. Do not let the paste get onto the slits of the oxygen sensor body.
- Connector color: Black.

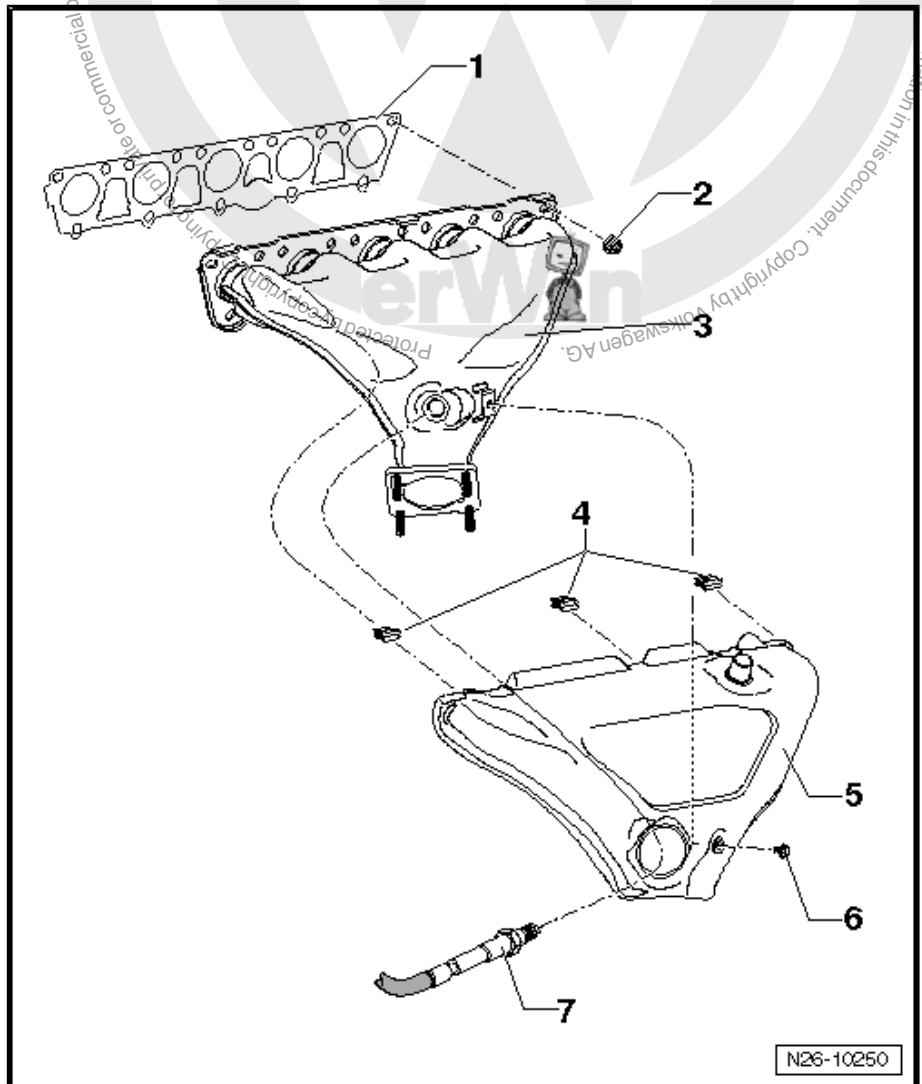



1.3 Exhaust Pipe with Catalytic Converter Overview

1 - Exhaust Manifold

- Coat the stud bolts with hot bolt paste.

2 - Gasket

- Always replace.
- Note the installation position:

Gasket recess -arrow A- must be located at the exhaust manifold recess -arrow B-.

3 - Nut

- 25 Nm
- Always replace.

4 - Exhaust Pipe with Catalytic Converter

- Protect from shocks and impact stress.
- With the coupling element.
- Do not bend the coupling element more than 10° - otherwise it may get damaged.
- Removing and installing. Refer to [⇒ "4.3 Exhaust Pipe with Catalytic Converter", page 189](#).
- Align the exhaust system free of tension. Refer to [⇒ "4.5 Exhaust System, Aligning", page 191](#).

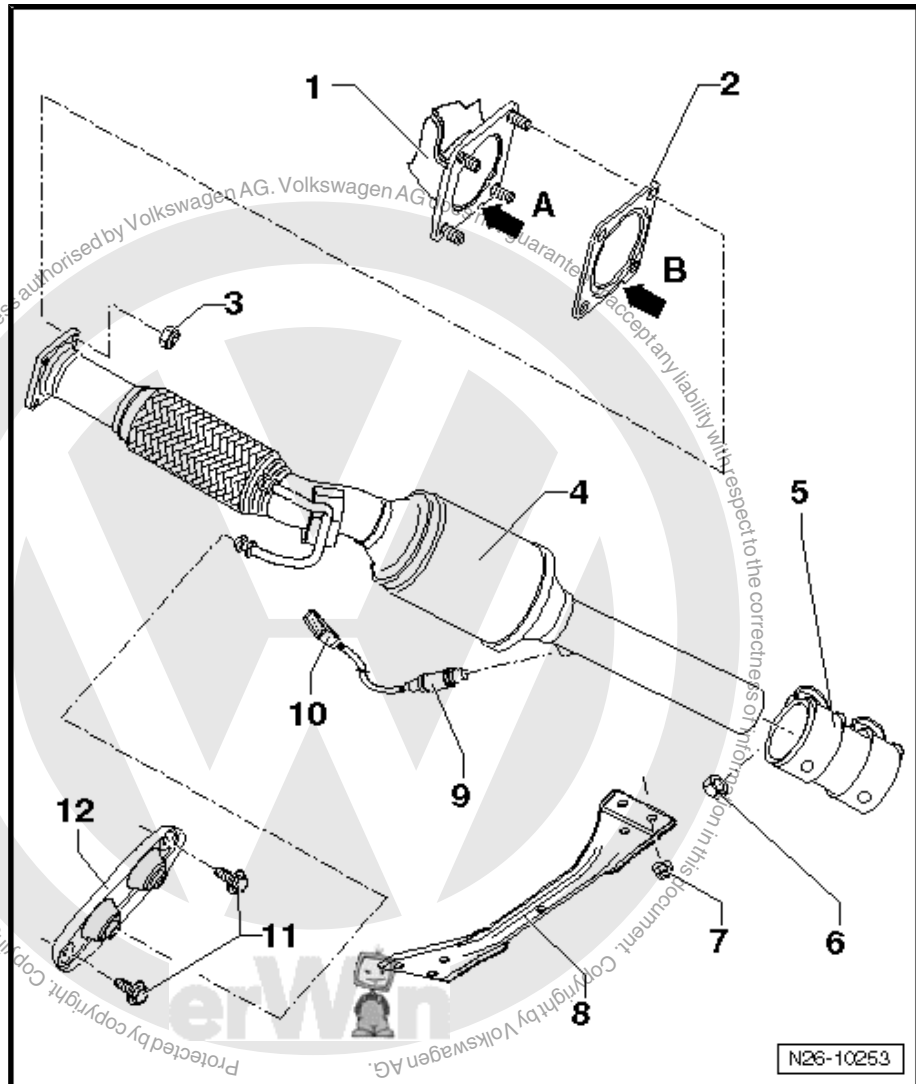

5 - Clamp

- Before tightening, ensure the exhaust system is free of tension. Refer to [⇒ "4.5 Exhaust System, Aligning", page 191](#).
- Installed position. Refer to [⇒ Fig. "Installed Position of the Clamp", page 181](#).

6 - Nut

- 25 Nm
- Tighten the nuts evenly.

7 - Nut

- 23 Nm

8 - Front Cross Member

9 - Oxygen Sensor after Three Way Catalytic Converter - G130-

- 55 Nm
- When reusing an old oxygen sensor again, only use hot bolt paste to grease the threads. Do not let the paste get onto the slits of the oxygen sensor body.

10 - Connector

- Brown, 4 pin
- Installed position. Refer to [⇒ Fig. "Oxygen Sensor Connector Installed Position", page 181](#).



11 - Bolt

- 25 Nm

12 - Suspended Mount

- Replace if damaged.

Installed Position of the Clamp

The -arrow- points in the direction of travel.

- Align the clamp -1- to the mark on the pipe -2-.

-a - = 5 mm

The bolts must not project beyond the lower edge of the clamp.

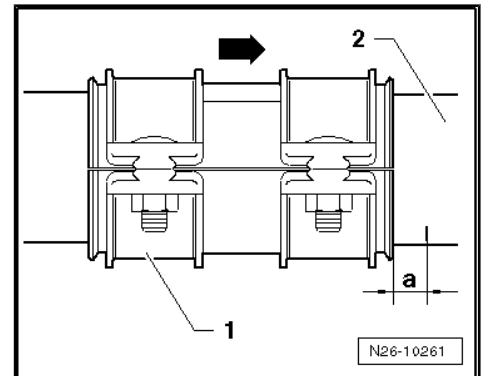

Oxygen Sensor Connector Installed Position

The connector is located to the right, on the vehicle floor under the cover.

- 1 - Bracket
- 2 - Oxygen sensor after three way catalytic converter connector, brown

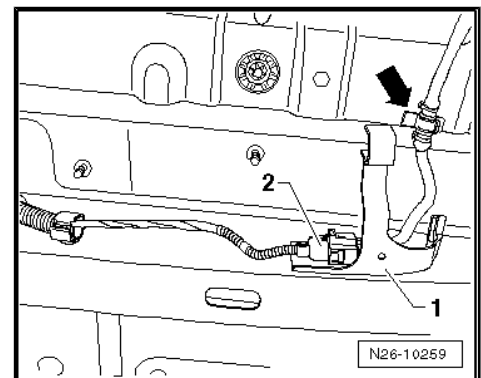



1.4 Exhaust Pipe with Catalytic Converter Overview

1 - Exhaust Manifold

- Coat the stud bolts with hot bolt paste.

2 - Gasket

- Always replace.
- Note the installed position:

Gasket recess -arrow A- must be located at exhaust manifold recess -arrow B-.

3 - Connector

- Black, 4 pin

4 - Oxygen Sensor in Bank 1 Center Three Way Catalytic Converter - G465-

- 55 Nm
- When reusing an old oxygen sensor again, only use hot bolt paste to grease the threads. Do not let the paste get onto the slits of the oxygen sensor body.

5 - Spring Nut

- Insert from the front.

6 - Clamp

- Before tightening, ensure the exhaust system is free of tension. Refer to ["4.5 Exhaust System, Aligning"](#), page 191 .

- Installed position. Refer to ["Fig. "Installed Position of the Clamp"](#), page 183 .

7 - Nut

- 25 Nm
- Tighten the nuts evenly.

8 - Nut

- 23 Nm

9 - Oxygen Sensor after Three Way Catalytic Converter - G130-

- 55 Nm
- When reusing an old oxygen sensor again, only use hot bolt paste to grease the threads. Do not let the paste get onto the slits of the oxygen sensor body.

10 - Connector

- Brown, 4 pin
- Installed position. Refer to ["Fig. "Oxygen Sensor Connector Installed Position"](#), page 183 .

11 - Front Cross Member

12 - Bolt

- 5 Nm

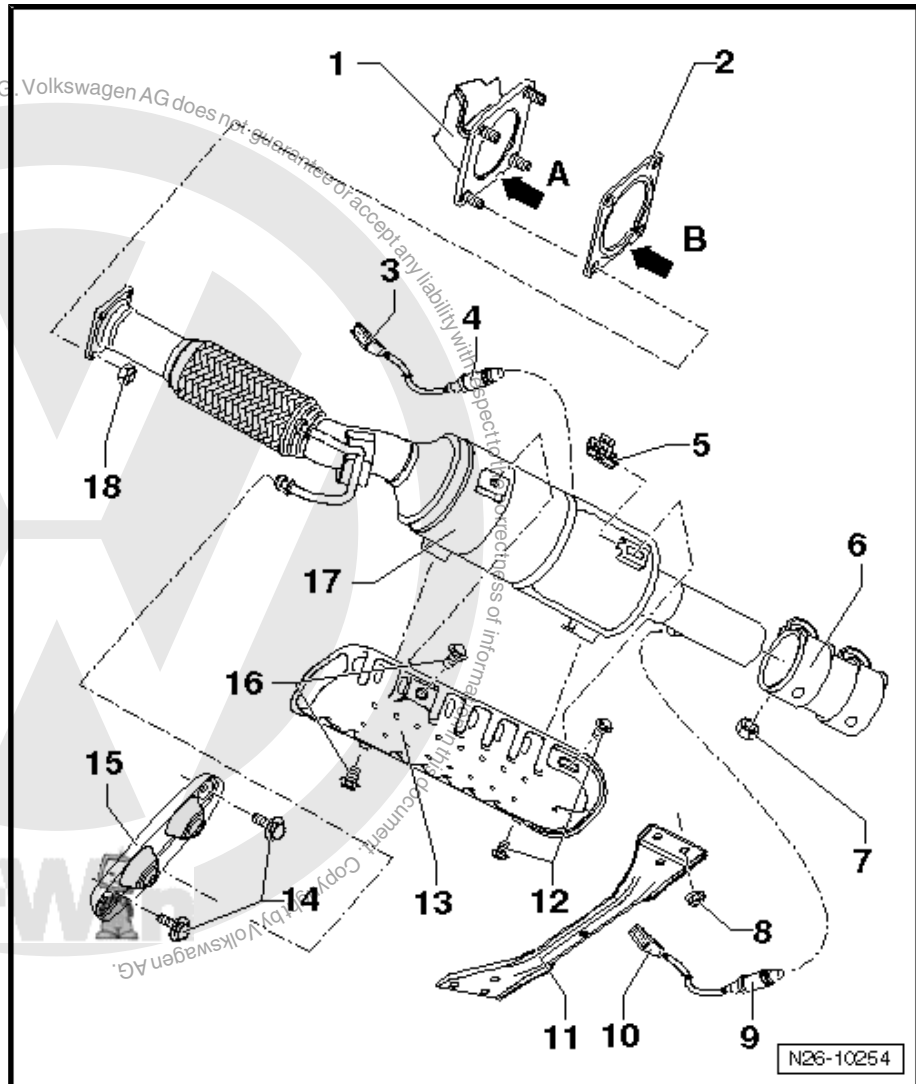



13 - Heat Shield

- For the catalytic converter.

14 - Bolt

- 25 Nm

15 - Suspended Mount

- Replace if damaged.

16 - Bolt

- 10 Nm

17 - Exhaust Pipe with Catalytic Converter

- Protect from shocks and impact stress.
- With the coupling element.
- Do not bend the coupling element more than 10° - otherwise it may get damaged.
- Removing and installing. Refer to ⇒ [“4.3 Exhaust Pipe with Catalytic Converter”, page 189](#)
- Align the exhaust system free of tension. Refer to ⇒ [“4.5 Exhaust System, Aligning”, page 191](#).

18 - Nut

- 25 Nm
- Always replace.

Installed Position of the Clamp

The -arrow- points in the direction of travel.

– Align the clamp -1- to the mark on the pipe -2-.

-a - = 5 mm

The bolts must not project beyond the lower edge of the clamp.

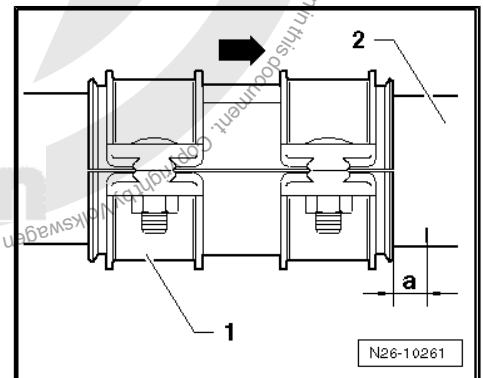

Oxygen Sensor Connector Installed Position

The connector is located to the right, on the vehicle floor under the cover.

- 1 - Oxygen sensor after three way catalytic converter connector, brown
- 2 - Bracket
- 3 - Oxygen sensor in bank 1 center three way catalytic converter connector, black

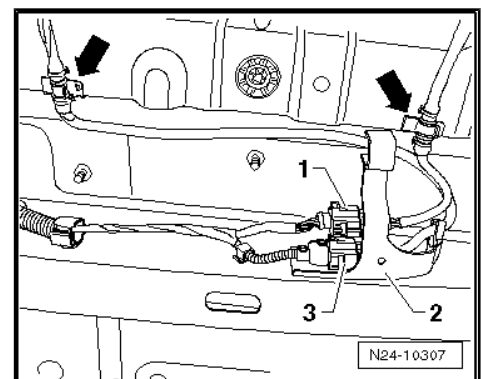



1.5 Muffler Overview



Note

- ◆ After exhaust system repairs, make sure the exhaust system is not under stress and that it has sufficient clearance from the body. If necessary, loosen the clamp(s) and align the exhaust pipe so that sufficient clearance is maintained to the body and the retaining rings carry uniform loads.
- ◆ Gaskets and self-locking nuts must be replaced.

1 - Front Muffler

2 - Suspended Mount

3 - Retaining Ring

- Replace if damaged.

4 - Nut

- 25 Nm

5 - Rear Muffler

- Factory installed with the front muffler as one unit. If repairs are necessary, replace separately.
- Align the exhaust system free of tension. Refer to ⇒ ["4.5 Exhaust System, Aligning"](#), page 191 .
- Separating the exhaust system. Refer to ⇒ ["4.4 Muffler"](#), page 190 .

6 - Suspended Mount

- Replace if damaged.

7 - Bolt

- 25 Nm

8 - Repair Clamp

- For individual replacement of the front and rear mufflers.
- Installed position. Refer to ⇒ ["4.4 Muffler"](#), page 190 .

- Tighten the nuts evenly.

9 - Center Muffler

- Factory installed with the rear muffler as one unit. If repair is necessary, replace separately.
- Align the exhaust system free of tension. Refer to ⇒ ["4.5 Exhaust System, Aligning"](#), page 191 .
- Separating the exhaust system. Refer to ⇒ ["4.4 Muffler"](#), page 190 .

10 - Bolt

- 25 Nm

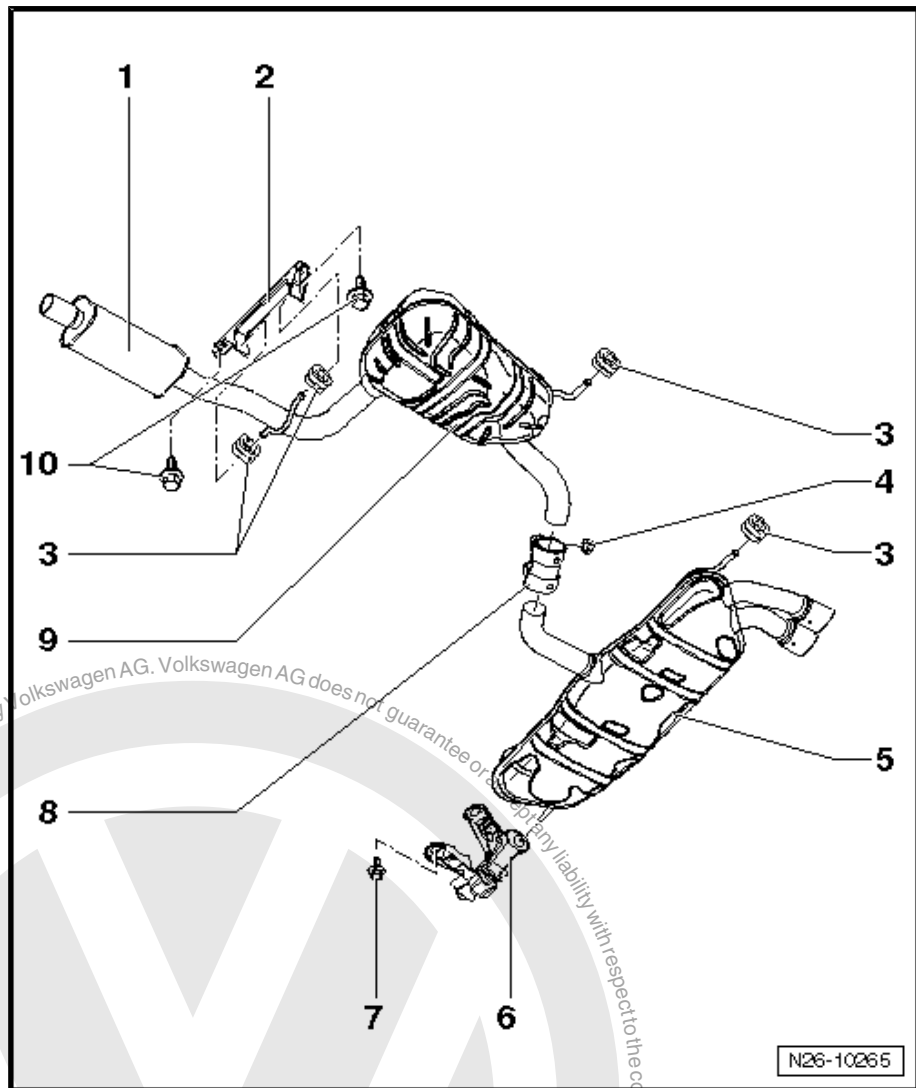



2 Specifications

⇒ **"2.1 Fastener Tightening Specifications", page 185**

2.1 Fastener Tightening Specifications

Secondary Air Injection (AIR) Pipe Bolt Tightening Sequence and Specification

- Tighten the bolts -1- first, then the bolt -2- and then the bolt -3- to 10 Nm.

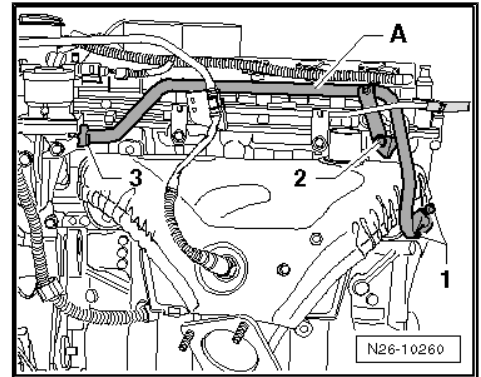



3 Diagnosis and Testing

⇒ ["3.1 Secondary Air Injection Solenoid Valve, Checking", page 186](#)

3.1 Secondary Air Injection Solenoid Valve, Checking

Special tools and workshop equipment required

- ◆ Connector Test Set - VAG1594C-
- ◆ Assisting Hose, for example, a Coolant Hose

Test Sequence



Note

Do not use compressed air during following check!

- Remove the engine cover with air filter. Refer to ⇒ ["5.1 Engine Cover with Air Filter", page 159](#) .
- Disconnect connecting pipe -2- from the Secondary Air Injection Solenoid Valve - N112- -3-. To do so, compress the securing ring.
- Disconnect the connector -4-.
- Slide the assisting hose -1-, for example, a coolant hose, onto the Secondary Air Injection (AIR) solenoid valve.
- Blow forcefully into the assisting hose -arrow-.
The valve must be closed.

If air can be blown through the valve with the assisting hose properly sealed:

- Replace the AIR solenoid valve.

If the valve is closed:

- Connect the terminals on the valve connection -5- with adapter cables from the Connector Test Set - VAG1594C- to battery positive (+) and negative (-).
- Blow forcefully into the assisting hose -arrow-.
The valve must be opened.

If no air can be blown through valve with assisting hose properly sealed:

- Replace the AIR solenoid valve. Refer to ⇒ ["4.2 Secondary Air Injection Solenoid Valve N112", page 188](#) .

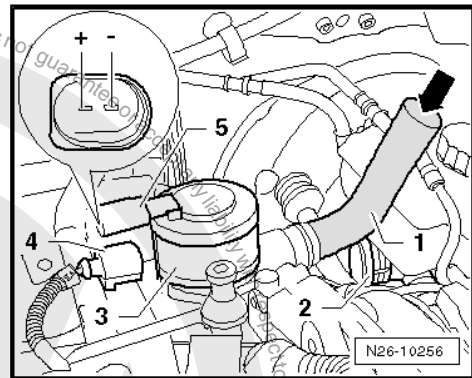



4 Removal and Installation

⇒ [“4.1 Secondary Air Injection Pump Motor V101”, page 187](#)

⇒ [“4.2 Secondary Air Injection Solenoid Valve N112”, page 188](#)

⇒ [“4.3 Exhaust Pipe with Catalytic Converter”, page 189](#)

⇒ [“4.4 Muffler”, page 190](#)

⇒ [“4.5 Exhaust System, Aligning”, page 191](#)

4.1 Secondary Air Injection Pump Motor - V101-

Removing

- Remove the throttle valve control module. Refer to ⇒ [“5.2 Throttle Valve Control Module J338”, page 159](#) .
- Disconnect the connecting pipes -1 and 2-. To do so, compress the securing rings.
- Remove the noise insulation. Refer to ⇒ Body Exterior; Rep. Gr. 50 ; Description and operation .
- Disconnect the connectors -1 and 2-.
- Press out the clip -3- for the wire guide.
- Press out the wire clip at the top front bolt.
- Remove the intake manifold support bolts -1- from the intake manifold.

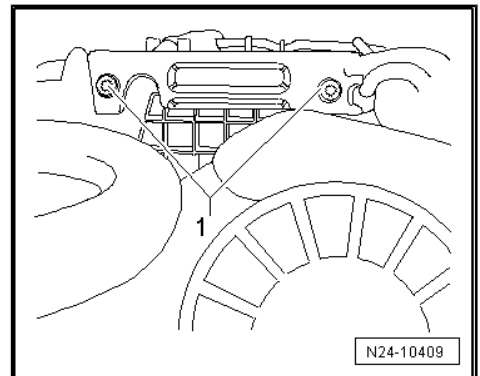
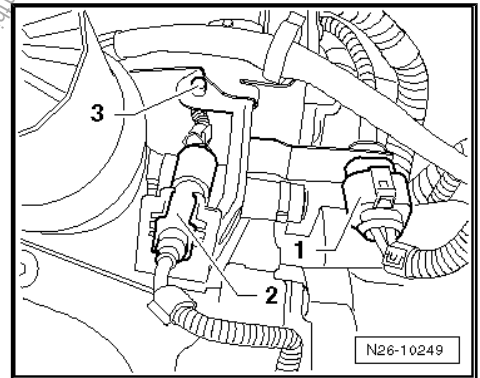
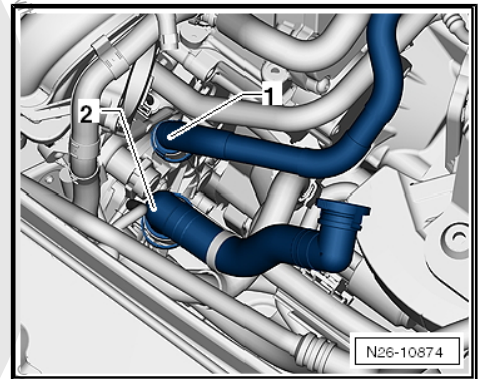



- Remove the lower bolt -arrow- from the intake manifold support.
- Move the intake manifold support slightly to the side. Remove the nuts and the AIR pump motor.

Installing

Install in reverse order of removal. Note the following:

- ◆ Make sure that connecting pipes lock securely to the AIR pump motor.

Tightening Specifications

Component	Nm
AIR pump motor to intake manifold support	10
Intake manifold support to intake manifold	Refer to => "1.1 Secondary Air Injection System Overview" , page 177

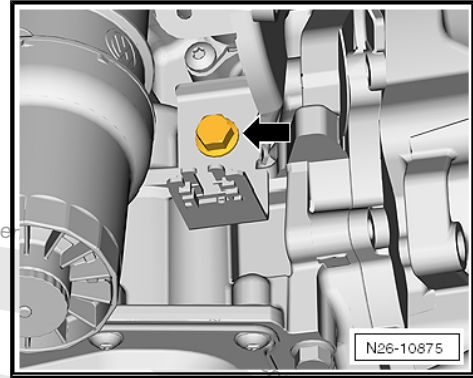

4.2 Secondary Air Injection Solenoid Valve - N112-

Removing

- Disconnect the connector -1- and remove the connecting pipe -2-.
- Remove the bolts -arrows- from the Secondary Air Injection (AIR) pipe.

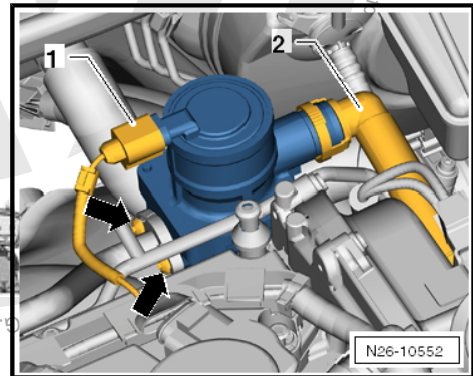

- Remove the bolts from the AIR solenoid valve and remove the valve.

Installing

- Replace the gaskets.
- Only tighten the bolts by hand.
- Tighten the AIR pipe bolts -arrows- to the AIR solenoid valve.

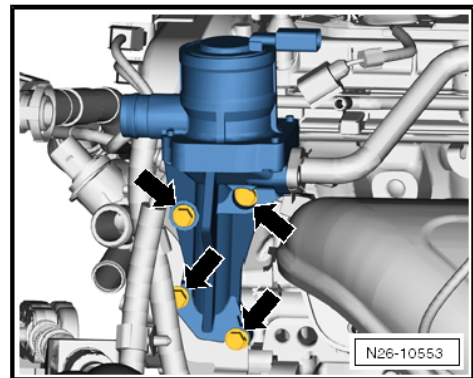



- Connect the connector -1- and connecting pipe -2-. Make sure the connecting pipe is seated securely.

Tightening Specifications

Component	Nm
AIR solenoid valve	10
AIR pipe	10

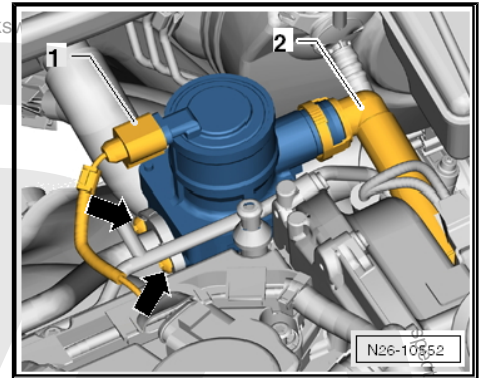

4.3 Exhaust Pipe with Catalytic Converter

Special tools and workshop equipment required

- ◆ Torque Wrench (5-50 Nm) VAG1331-
- ◆ Hot Bolt Paste. Refer to the Parts Catalog

Removing

- Remove the right underbody trim retainers -arrows- and trim.

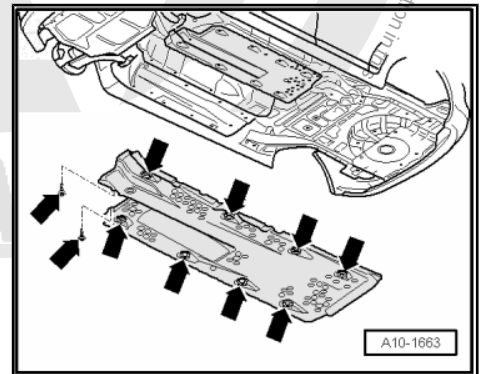

Engine Codes BGP and CBTA

- Unclip the wire -arrow-, pull off the bracket -1- and disconnect the connector for oxygen sensor after three way catalytic converter - G130- -2-.

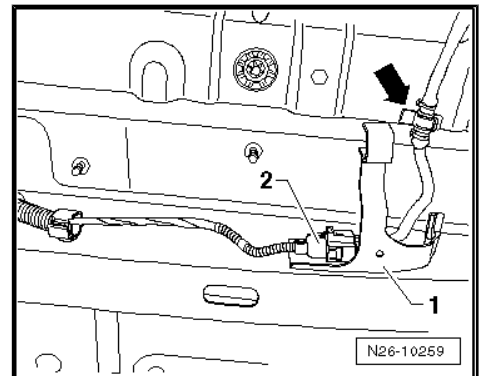

Engine Codes BGQ and CBUA

- Unclip the wires -arrows-, pull off the bracket -2- and disconnect the connectors for the oxygen sensor in bank 1 center three way catalytic converter -1- and for the oxygen sensor in bank 1 center three way catalytic converter - G465- -3-.

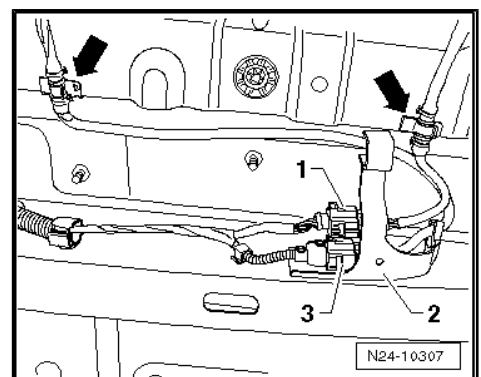



Continuation for All

- Loosen the clamp -1- nuts. The front cross member must not be removed.



Note

The coupling element in the exhaust pipe with catalytic converter must not be bent more than 10°, otherwise it may be damaged.

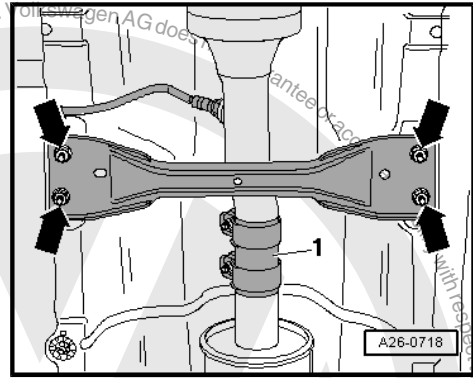

- Remove the exhaust pipe with catalytic converter to exhaust manifold nuts -2- and the suspended mount bolts -3-.
- Remove the exhaust pipe with catalytic converter -1- from the exhaust manifold, slide toward the front at the sides and guide it under the front cross member.

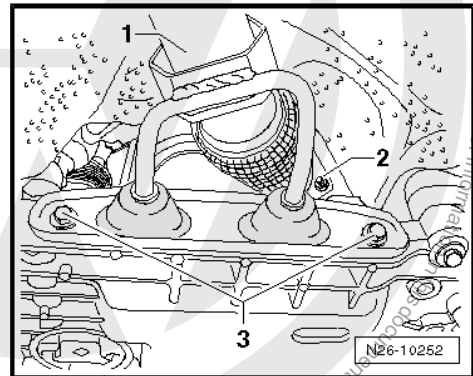

Installing

Install in reverse order of removal. Note the following:

- ◆ Replace gaskets and self-locking nuts.
- ◆ Install the exhaust system free of stress. Refer to [⇒ "4.5 Exhaust System, Aligning", page 191](#).

Tightening Specifications

Component	Nm
Exhaust pipe with catalytic converter to exhaust manifold ◆ Replace nuts	25 ¹
Suspended mount to subframe	25
Clamp	25

- ◆ ¹ Coat the stud bolts on the exhaust manifold with hot bolt paste

4.4 Muffler



Note

- ◆ A separating point has been provided in the connecting pipe for individual replacement of the front or rear muffler.
- ◆ The separating point is marked by depressions around the circumference of the exhaust pipe.

Special tools and workshop equipment required

- ◆ Body Repair Saw - VAG1523A- or
- ◆ Chain Pipe Cutter - VAS6254-
- ◆ Protective Eyewear



Separating



WARNING

To prevent injuries from metal shavings, wear protective goggles and protective clothing.

- Cut the exhaust pipe at the separation point -arrow 2- using for example, the Body Repair Saw - VAG1523A- at a right angle.

Joining



Note

A second technician is needed to install the repair clamp.

Secure the front muffler in the retainers. The front clamp remains loosely connected to the pipes.

Align the rear muffler horizontally and hold it in this position.

Position the repair clamp at the side marks -arrows 1 and 3-.

Position the repair clamp -A- as shown and tighten it to 25 Nm.

Then, align the exhaust system free of tension. Refer to ["4.5 Exhaust System, Aligning", page 191](#).

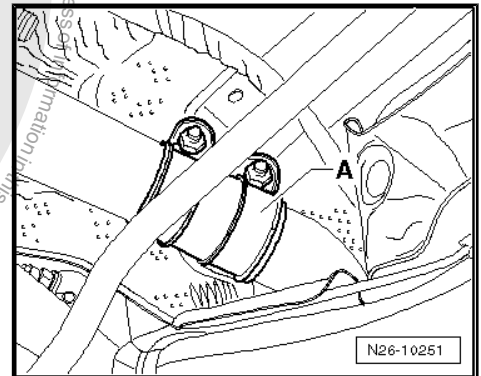
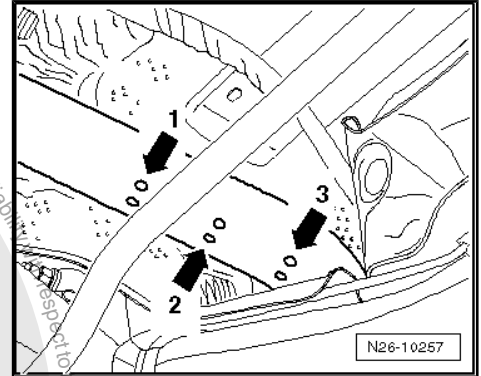

4.5 Exhaust System, Aligning

- Align the exhaust system when cold.
- Loosen the front double clamp bolts.
- Push the exhaust system far enough forward so that the pre-tension at the retaining rings at the rear muffler = 15 to 17 mm -a-.

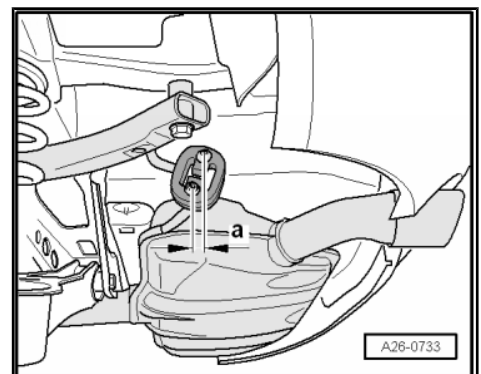



- Install the clamping sleeve so that the end of the bolt does not extend beyond the lower edge of the clamping sleeve.
- Threaded connection points toward the right.
- Tighten the clamping sleeve bolts uniformly to 25 Nm.

Aligning the Tailpipe

- Align the rear muffler so the distance -a- between the bumper opening and right and left tail pipes is equal.
- Distance -b- from the bumper opening to the tail pipes must be parallel.
- Loosen the rear muffler mounts to align the tail pipes, if necessary.

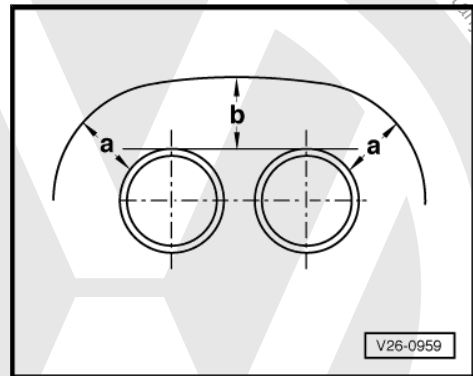
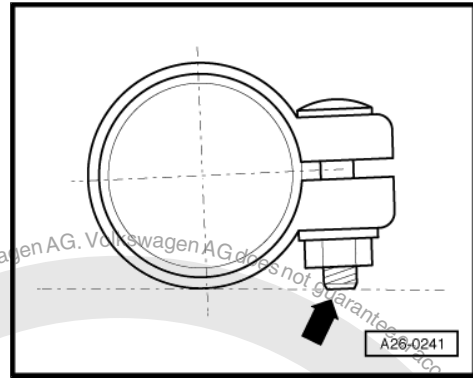



5 Special Tools

Special tools and workshop equipment required

- ◆ Connector Test Set - VAG1594C-

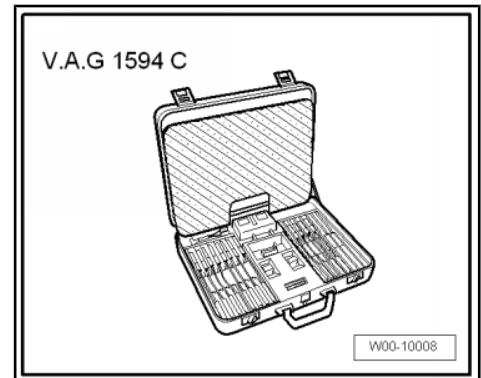

- ◆ Torque Wrench (5-50 Nm) - VAG1331-

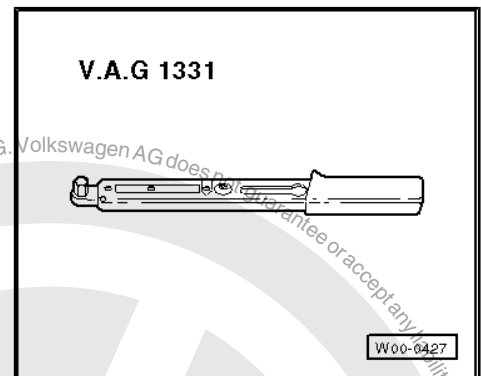

- ◆ Body Repair Saw - VAG1523A-

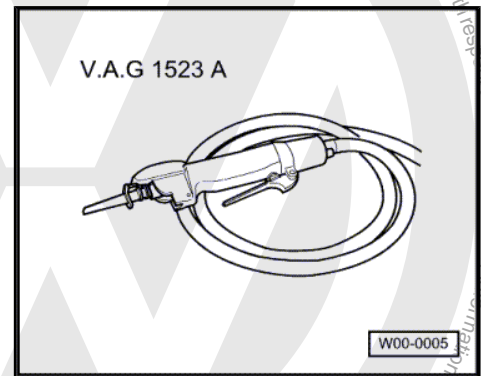

- ◆ Chain Pipe Cutter - VAS6254-

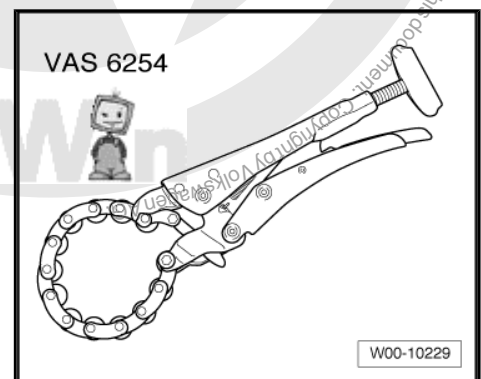



28 – Ignition/Glow Plug System

1 Description and Operation

⇒ [“1.1 Ignition System Component Overview”, page 194](#)

⇒ [“1.2 Knock Sensor Overview”, page 196](#)

1.1 Ignition System Component Overview



Note

- ◆ *For trouble free operation of the electrical components a voltage of at least 11.5 volts is necessary.*
- ◆ *It is possible that the control module will recognize a malfunction and store a Diagnostic Trouble Code (DTC) during some tests. After completing all checks and repairs, check the DTC memory and erase the memory, if necessary.*
- ◆ *If the engine only starts briefly and then shuts off again after troubleshooting, repairs or checking of the components, it may be that the immobilizer is blocking the Engine Control Module (ECM). The ECM may have to be adapted. Refer to the vehicle diagnostic tester.*



1 - Knock Sensor 2 Connector

- Gray
- Contacts are gold plated.
- Installed position. Refer to
⇒ [Fig. "Installation Position of the Knock Sensor Connectors"](#), page 196 .

2 - Knock Sensor 1 Connector

- Green
- Contacts are gold plated.
- Installed position. Refer to
⇒ [Fig. "Installation Position of the Knock Sensor Connectors"](#), page 196 .

3 - Knock Sensor 2 - G66-

- Installed position: The wire connection points 45° toward the right on the outside.
- Overview. Refer to
⇒ ["1.2 Knock Sensor Overview"](#), page 196 .

4 - Knock Sensor 1 - G61-

- Installed position: The wire connection points downward vertically.
- Overview. Refer to
⇒ ["1.2 Knock Sensor Overview"](#), page 196 .

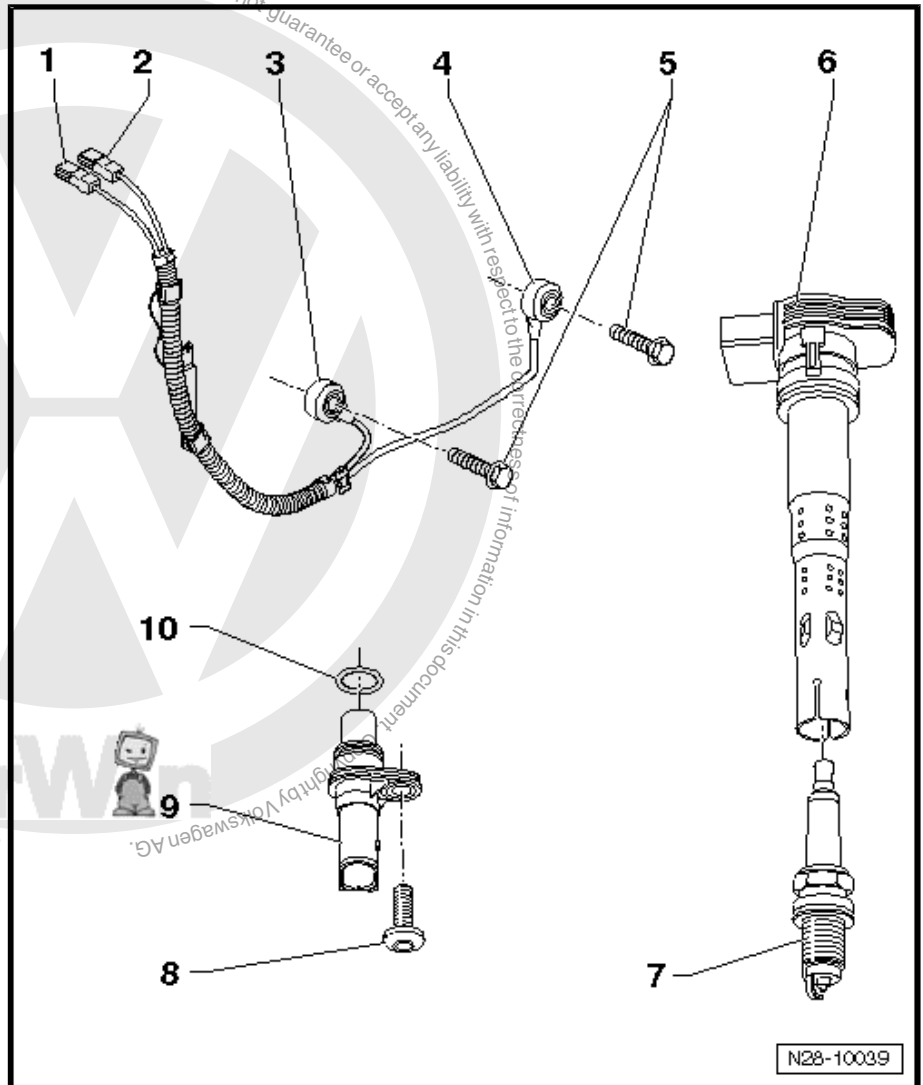

5 - Bolt

- 20 Nm
- Tightening specification affects the function of the knock sensor.

6 - Ignition Coil with Power Output Stage - N70, N127, N291, N292, N323-

- Removing and installing. Refer to ⇒ ["3.1 Ignition Coil with Power Output Stage"](#), page 199 .

7 - Spark Plug

- 25 Nm
- Type and electrode gap. Refer to ⇒ ["2.1 Test Data and Spark Plugs"](#), page 198 .
- Remove and install using the Spark Plug Removal Tool - 3122B- .

8 - Bolt

- 10 Nm

9 - Camshaft Position Sensor - G40-

- Contacts are gold plated.

10 - O-ring

- Replace if damaged.



Installation Position of the Knock Sensor Connectors

- 1 - Green for the knock sensor 1
- 2 - Gray for the knock sensor 2

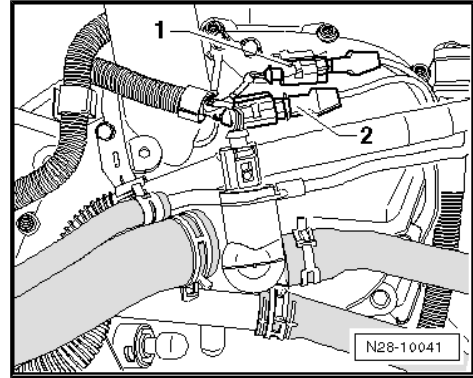

1.2 Knock Sensor Overview

Note

Two sensors are installed knock sensor 1 and knock sensor 2.

1 - Cylinder Block

2 - Locking Bolt

- 30 Nm
- With a rolled seal.
- The bore in the cylinder block is for locking the crankshaft with Locking Pin - T40069- .

3 - Knock Sensor 1 - G61-

- Note the installed position: The wire connection points downward vertically.

4 - Bolt

- 20 Nm
- Tightening specification affects the function of the knock sensor.

5 - Bolt

- 10 Nm

6 - Cover

7 - Plug

8 - Wire Clip

- Clamped on cover plate

9 - Knock Sensor 2 - G66-

- Note the installed position: The wire connection points 45° toward the right on the outside.

10 - Wire Bracket

- Bolted to Secondary Air Injection (AIR) valve.

11 - Connector

- Green for the knock sensor 1.

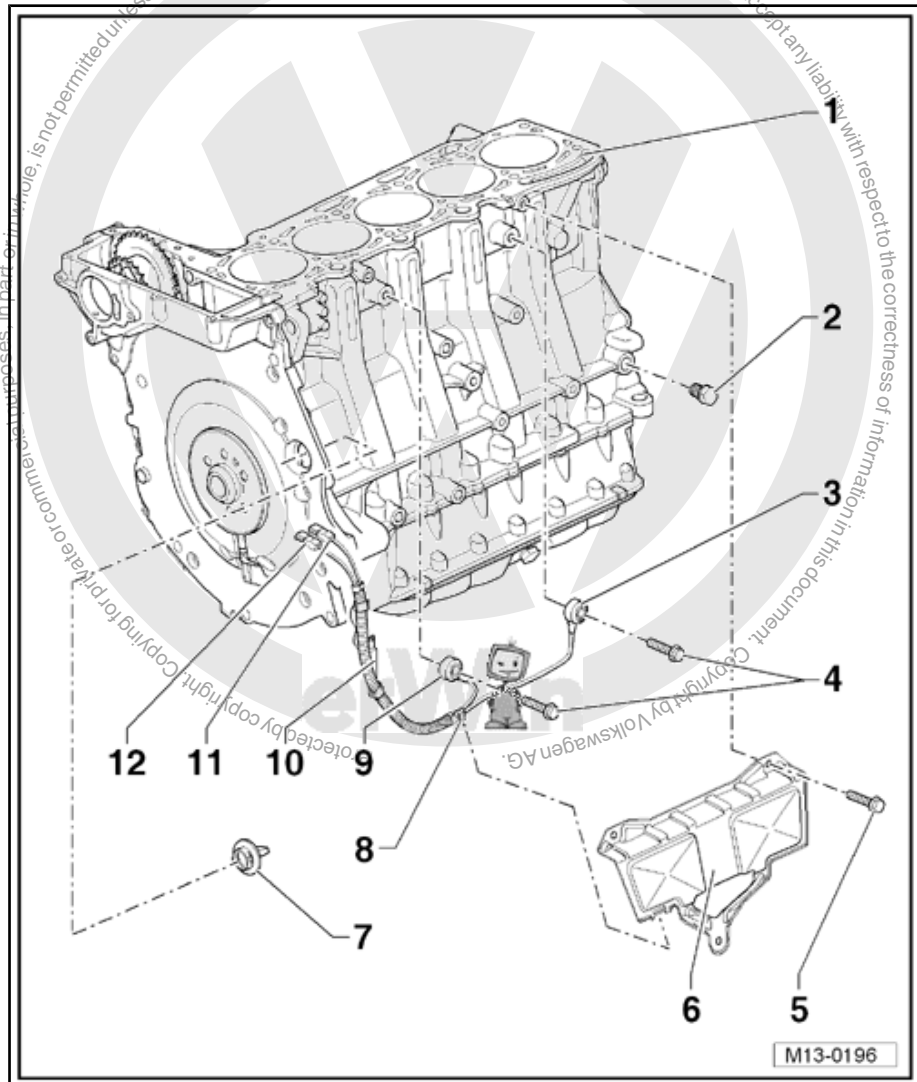



- Installed position. Refer to => [Fig. "Installed Position of the Knock Sensor Connectors"](#) , page 197 .
- Contacts are gold plated.

12 - Connector

- Gray for the knock sensor 2.
- Installed position. Refer to => [Fig. "Installed Position of the Knock Sensor Connectors"](#) , page 197 .
- Contacts are gold plated.

Installed Position of the Knock Sensor Connectors

- 1 - Green for knock sensor 1
- 2 - Gray for knock sensor 2

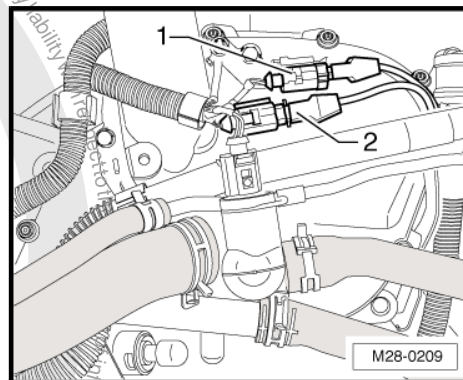



2 Specifications

⇒ "2.1 Test Data and Spark Plugs", page 198

2.1 Test Data and Spark Plugs

Engine Codes	BGP, BGQ, CBTA and CBUA
Ignition sequence	1-2-4-5-3
Spark plugs	
VW/Audi	Refer to the Parts Catalog
Electrode gap	1.0 to 1.1 mm
Tightening specification	25 Nm
Change intervals	Refer to the Maintenance Intervals, Rep. Gr. 03

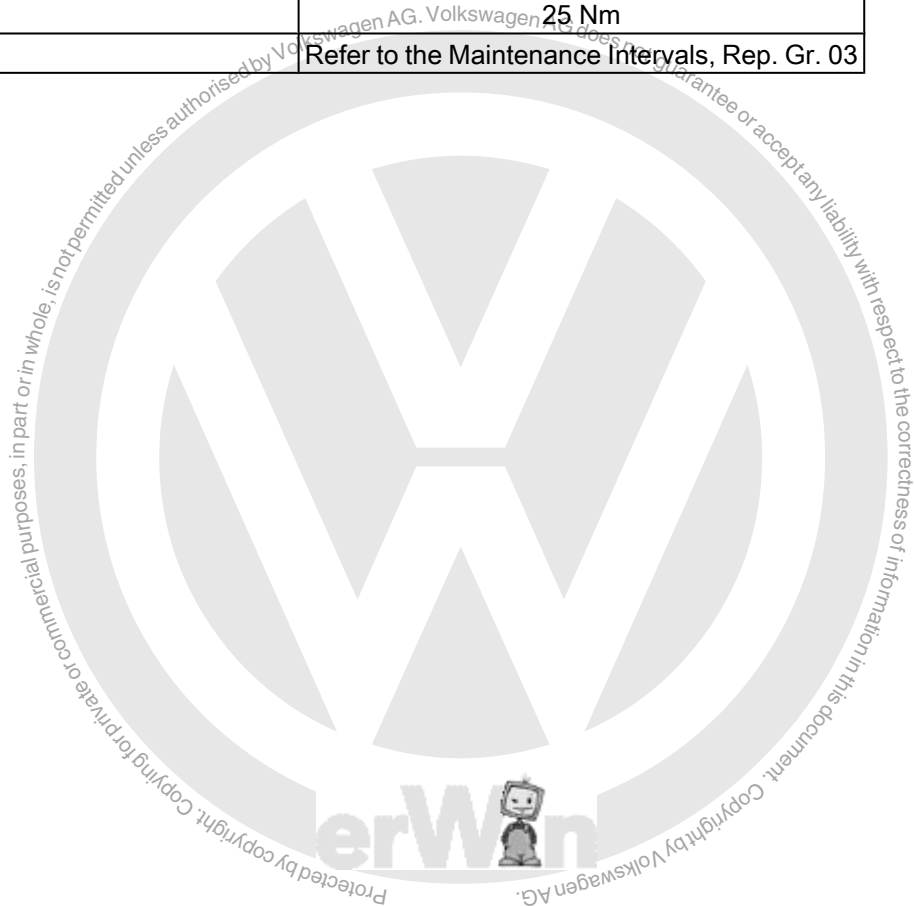



3 Removal and Installation

⇒ **“3.1 Ignition Coil with Power Output Stage”, page 199**

3.1 Ignition Coil with Power Output Stage

Special tools and workshop equipment required

- ◆ Ignition Coil Puller - T40039-
- ◆ Special Lubricant - G052141A2-

Removing



Note

- ◆ *To remove from the spark plugs, place the Ignition Coil Puller - T40039- on the top most thick rib -arrow- of the ignition coil with power output stage.*
- ◆ *The lower ribs may be damaged if they are used.*
- Remove the engine cover with air filter. Refer to
 ⇒ **“5.1 Engine Cover with Air Filter”, page 159** .
- Disconnect the connector -arrow- from the Secondary Air Injection Solenoid Valve - N112- , if applicable.

In order to prevent damage to the wire guide, remove the ignition coil with power output stage as follows:

- Pull all the ignition coils approximately 10 mm out of the spark plug shaft using the Ignition Coil Puller - T40039- . Start with ignition coil -1-.
- Then, pull out all ignition coils a further 10 mm in the same sequence.
- Disengage all connectors and pull them out only slightly.

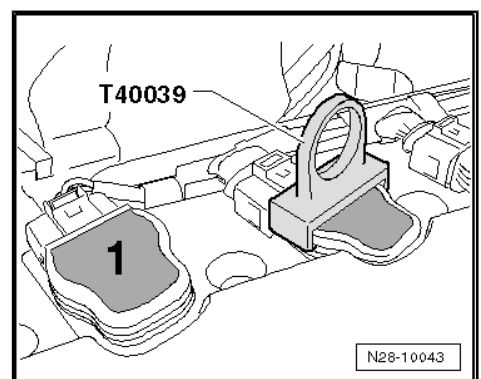
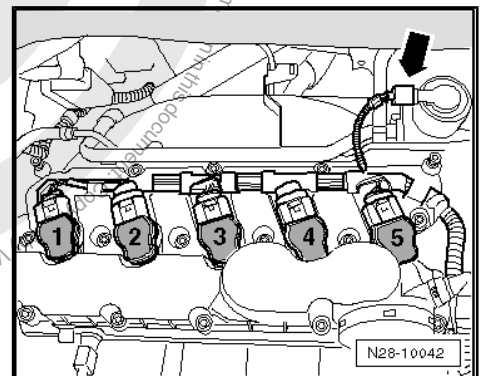
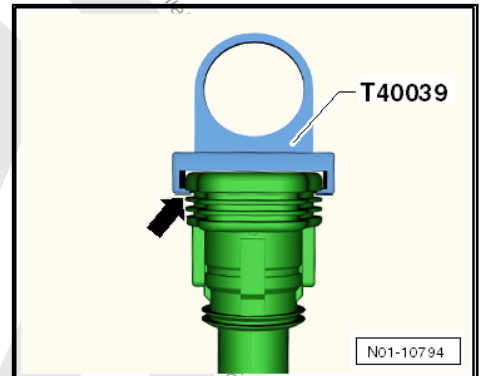



- Disconnect all the connectors -A- starting at ignition coil -1- and remove the ignition coils from the spark plug shaft.

Installing

- Insert all ignition coils loosely into the spark plug shaft.
- Align the ignition coils to the recesses in the cylinder head cover. Connect all the connectors to the ignition coils in the opposite order.
- Press the ignition coils evenly onto the spark plugs by hand.

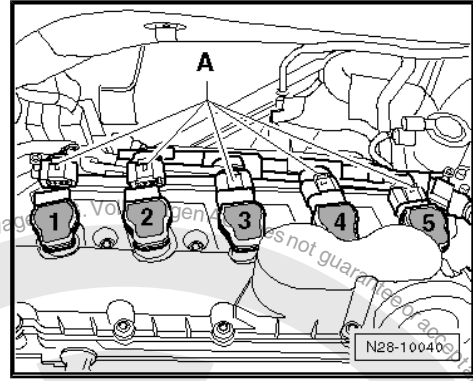



4 Special Tools

Special tools and workshop equipment required

- ◆ Ignition Coil Puller - T40039-

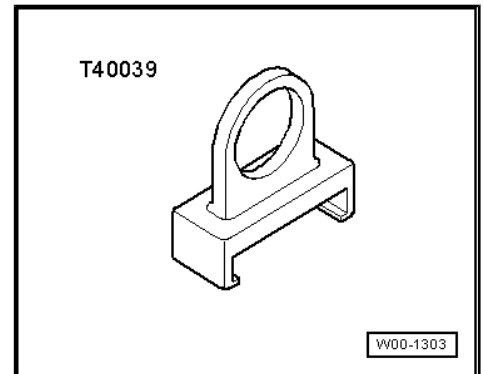

Edition 01/08/2015 - USA51206521 - FU - ESP





5 Revision History

Re- vi- sion	Date	Job Type	Feedback #	Notes	Editor
2	01/08/2014	Factory Update	N/A		Eric Puterbaugh
1	07/221/2014	Local Feedback	1028415		Eric Puterbaugh

Cautions & Warnings

Please read these WARNINGS and CAUTIONS before proceeding with maintenance and repair work. You must answer that you have read and you understand these WARNINGS and CAUTIONS before you will be allowed to view this information.

- If you lack the skills, tools and equipment, or a suitable workshop for any procedure described in this manual, we suggest you leave such repairs to an authorized Volkswagen retailer or other qualified shop. We especially urge you to consult an authorized Volkswagen retailer before beginning repairs on any vehicle that may still be covered wholly or in part by any of the extensive warranties issued by Volkswagen.
- Disconnect the battery negative terminal (ground strap) whenever you work on the fuel system or the electrical system. Do not smoke or work near heaters or other fire hazards. Keep an approved fire extinguisher handy.
- Volkswagen is constantly improving its vehicles and sometimes these changes, both in parts and specifications, are made applicable to earlier models. Therefore, part numbers listed in this manual are for reference only. Always check with your authorized Volkswagen retailer parts department for the latest information.
- Any time the battery has been disconnected on an automatic transmission vehicle, it will be necessary to reestablish Transmission Control Module (TCM) basic settings using the VAG 1551 Scan Tool (ST).
- Never work under a lifted vehicle unless it is solidly supported on stands designed for the purpose. Do not support a vehicle on cinder blocks, hollow tiles or other props that may crumble under continuous load. Never work under a vehicle that is supported solely by a jack. Never work under the vehicle while the engine is running.
- For vehicles equipped with an anti-theft radio, be sure of the correct radio activation code before disconnecting the battery or removing the radio. If the wrong code is entered when the power is restored, the radio may lock up and become inoperable, even if the correct code is used in a later attempt.
- If you are going to work under a vehicle on the ground, make sure that the ground is level. Block the wheels to keep the vehicle from rolling. Disconnect the battery negative terminal (ground strap) to prevent others from starting the vehicle while you are under it.
- Do not attempt to work on your vehicle if you do not feel well. You increase the danger of injury to yourself and others if you are tired, upset or have taken medicine or any other substances that may impair you or keep you from being fully alert.
- Never run the engine unless the work area is well ventilated. Carbon monoxide (CO) kills.
- Always observe good workshop practices. Wear goggles when you operate machine tools or work with acid. Wear goggles, gloves and other protective clothing whenever the job requires working with harmful substances.
- Tie long hair behind your head. Do not wear a necktie, a scarf, loose clothing, or a necklace when you work near machine tools or running engines. If your hair, clothing, or jewelry were to get caught in the machinery, severe injury could result.
- Do not re-use any fasteners that are worn or deformed in normal use. Some fasteners are designed to be used only once and are unreliable and may fail if used a second time. This includes, but is not limited to, nuts, bolts, washers, circlips and cotter pins. Always follow the recommendations in this manual - replace these fasteners with new parts where indicated, and any other time it is deemed necessary by inspection.

Cautions & Warnings

- Illuminate the work area adequately but safely. Use a portable safety light for working inside or under the vehicle. Make sure the bulb is enclosed by a wire cage. The hot filament of an accidentally broken bulb can ignite spilled fuel or oil.
- Friction materials such as brake pads and clutch discs may contain asbestos fibers. Do not create dust by grinding, sanding, or by cleaning with compressed air. Avoid breathing asbestos fibers and asbestos dust. Breathing asbestos can cause serious diseases such as asbestosis or cancer, and may result in death.
- Finger rings should be removed so that they cannot cause electrical shorts, get caught in running machinery, or be crushed by heavy parts.
- Before starting a job, make certain that you have all the necessary tools and parts on hand. Read all the instructions thoroughly; do not attempt shortcuts. Use tools that are appropriate to the work and use only replacement parts meeting Volkswagen specifications. Makeshift tools, parts and procedures will not make good repairs.
- Catch draining fuel, oil or brake fluid in suitable containers. Do not use empty food or beverage containers that might mislead someone into drinking from them. Store flammable fluids away from fire hazards. Wipe up spills at once, but do not store the oily rags, which can ignite and burn spontaneously.
- Use pneumatic and electric tools only to loosen threaded parts and fasteners. Never use these tools to tighten fasteners, especially on light alloy parts. Always use a torque wrench to tighten fasteners to the tightening torque listed.
- Keep sparks, lighted matches, and open flame away from the top of the battery. If escaping hydrogen gas is ignited, it will ignite gas trapped in the cells and cause the battery to explode.
- Be mindful of the environment and ecology. Before you drain the crankcase, find out the proper way to dispose of the oil. Do not pour oil onto the ground, down a drain, or into a stream, pond, or lake. Consult local ordinances that govern the disposal of wastes.
- The air-conditioning (A/C) system is filled with a chemical refrigerant that is hazardous. The A/C system should be serviced only by trained automotive service technicians using approved refrigerant recovery/recycling equipment, trained in related safety precautions, and familiar with regulations governing the discharging and disposal of automotive chemical refrigerants.
- Before doing any electrical welding on vehicles equipped with anti-lock brakes (ABS), disconnect the battery negative terminal (ground strap) and the ABS control module connector.
- Do not expose any part of the A/C system to high temperatures such as open flame. Excessive heat will increase system pressure and may cause the system to burst.
- When boost-charging the battery, first remove the fuses for the Engine Control Module (ECM), the Transmission Control Module (TCM), the ABS control module, and the trip computer. In cases where one or more of these components is not separately fused, disconnect the control module connector(s).
- Some of the vehicles covered by this manual are equipped with a supplemental restraint system (SRS), that automatically deploys an airbag in the event of a frontal impact. The airbag is operated by an explosive device. Handled improperly or without adequate safeguards, it can be accidentally activated and cause serious personal injury. To guard against personal injury or airbag system failure, only trained Volkswagen Service technicians should test, disassemble or service the airbag system.

Cautions & Warnings

- Do not quick-charge the battery (for boost starting) for longer than one minute, and do not exceed 16.5 volts at the battery with the boosting cables attached. Wait at least one minute before boosting the battery a second time.
- Never use a test light to conduct electrical tests of the airbag system. The system must only be tested by trained Volkswagen Service technicians using the VAG 1551 Scan Tool (ST) or an approved equivalent. The airbag unit must never be electrically tested while it is not installed in the vehicle.
- Some aerosol tire inflators are highly flammable. Be extremely cautious when repairing a tire that may have been inflated using an aerosol tire inflator. Keep sparks, open flame or other sources of ignition away from the tire repair area. Inflate and deflate the tire at least four times before breaking the bead from the rim. Completely remove the tire from the rim before attempting any repair.
- When driving or riding in an airbag-equipped vehicle, never hold test equipment in your hands or lap while the vehicle is in motion. Objects between you and the airbag can increase the risk of injury in an accident.

I have read and I understand these Cautions and Warnings.